

The SBC-050A combines the high performance OCP-050 TEC/fan-based cooling module with the BA-02 butterfly laser diode socket. It is an affordable, high performance solution for cooling butterfly laser diodes in the laboratory environment, and there is sufficient cooling plate area to mount additional components.

The functional hole patterns are shown in the figure below. Custom mounting holes patterns are available upon request.

The cold plate is electrically isolated from the heatsink and the fan duct: it is safe to mount the laser diode package directly on the cold plate using indium foil.

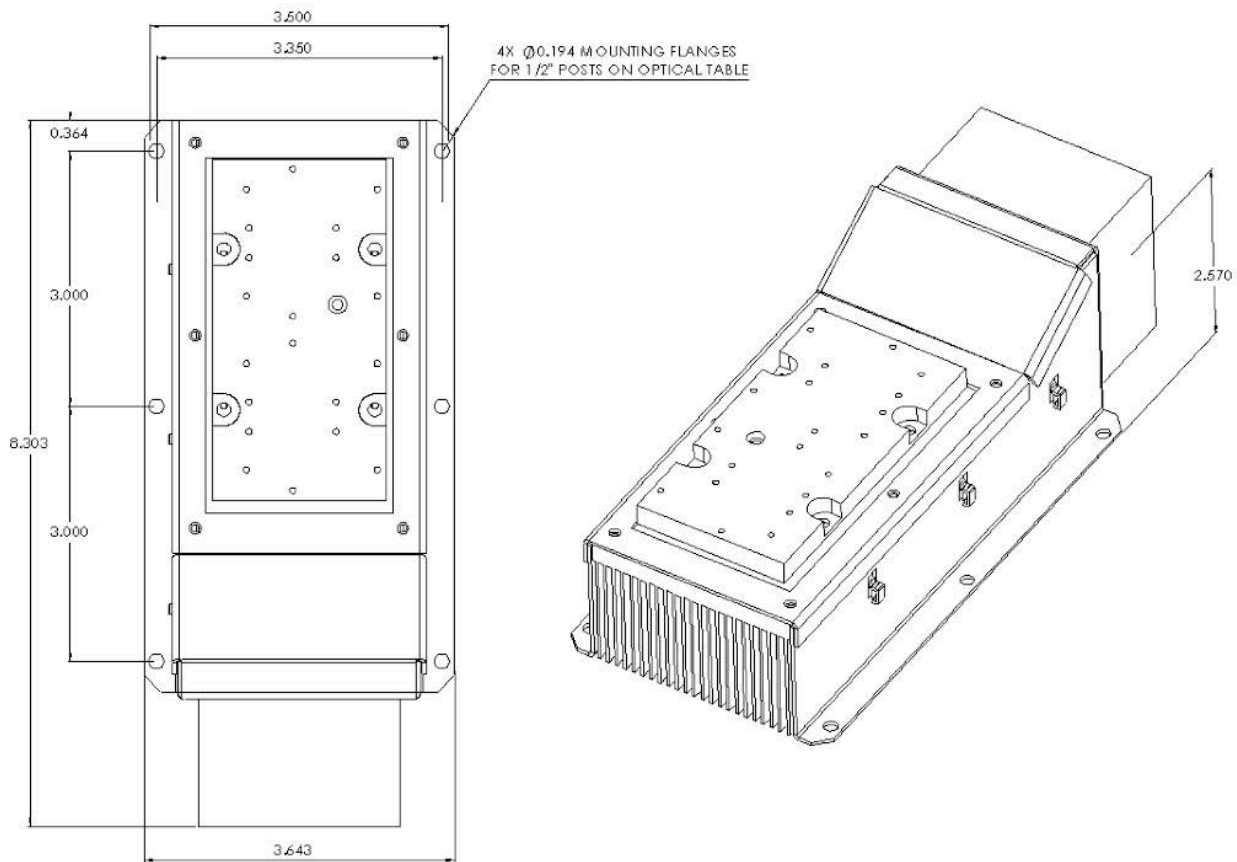

Table 1 below lists the pinout designations for the terminal block connector:

Pin #	Designation
1	TEC +
2	TEC -
3	Fan +
4	Fan -
5	Thermistor sensor VDD+GND
6	Thermistor sensor DQ

2. Performance curve

The curve illustrates the performance of OCP-050A. The Y-axis is the heat load to the coldplate, the X-axis is the delta between the lowest temperature on cold plate and ambient at the given heat load. Please notice that the cold plate temperature is an average figure, the temperature directly underneath the diode source will be higher and the edge of the cold plate will be lower. The plate temperature thermistor is mounted internally, and is located beneath the butterfly laser mounting position that is closest to the fan.

This curve is obtained with 3.6 Amps current to each TEC with the cold side set at 25°C. The performance will improve in hotter set points and decrease if the set point is lower.

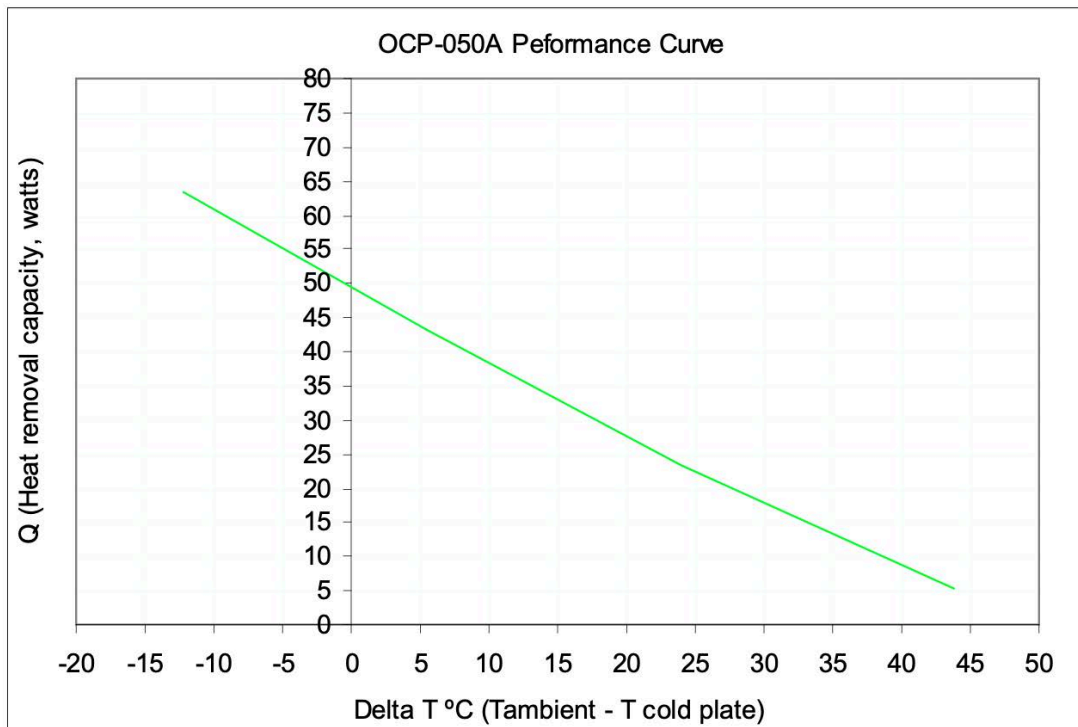

3. Cooling Approach

The fan pulls air away from front of heatsink in our standard configuration of the cooling module. It makes it easy to use on optical table with CS diode mounted on it since the air is pulling away from the optics. For applications where pushing air out from the front is not a concern, users can easily take the fan off and change the direction of the airflow; the performance will be slight better.

4. Cooling Fan Specifications (2 Fans in Parallel)

Parameters	Standard
Rated voltage	12 VDC
Operating voltage range	5.5 - 13.8 VDC
Input power	9.9 W
Rated current	0.83 A
Noise	47 dBA

5. TEC specifications

The maximum operating current for the TEC is 4.2 A, and maximum voltage is 24 VDC at room temperature. Maximum operating current and voltage increases with ambient. Exceeding the specified maximum current will reduce the performance and degrade the reliability of TECs.

The typical optimum current for each TEC is about 3 ~ 4 Amps depends on the set temperature, heat load, interface quality between the diode and cold plate, and ambient temperature. Users are advised to manually ramp the TEC driving current after assembling the diode on the cold plate to identify the optimum current and set current limit accordingly so that the TEC will not runaway. All TECs are environmentally sealed for operating below dew points.

6. Diode Cooling Interface Guidelines

The actual performance of the cooling module is extremely sensitive to the quality of the thermal interface between the cold plate and the diode. For high power laser modules with large footprints, it is very difficult to maintain a uniform high quality interface. Our cold plate is made of copper with very low spreading resistance so that the user can focus on the area directly underneath the laser diode. If the laser diode set temperature is significantly below ambient, we highly recommend using thermal insulation materials such as silicone foam or ceramic-based insulation to insulate laser from ambient.

The Model BA-02 Universal Butterfly Mounts Kit provides electrical connections and a robust thermal contact to the surface of the cooling plate. The BA-Series mount kit interfaces directly with the OCP-050 thermoelectric cold plate assembly.

The SBC-050A includes the universal butterfly mount, BA-02. The prewired BA-01 butterfly laser diode mount is available for standard pump laser pinouts.

- BA-01 is prewired for standard pump laser pinouts to the 20-pin connector at the end of PCB, and provides reverse bias protection for laser diode. The BA-01 pin connection table is shown at the end of this document.
- BA-02 routes all butterfly connections to the 20-pin connector at the end of PCB, making it an universal butterfly adapter. The BA-02 pin connection table is shown on the next page.

The zero insertion force (ZIF) electrical PCB headers are spring loaded to maintain robust electrical continuity when compressed by the butterfly clamp. The height of the electrical contacts matches the height of butterfly pins, causing no stress to the pins while maintaining robust electrical contact.

An electrical isolation sheet is provided to ensure electrical isolation between the circuit board and the heat sink mounting surface.

All mounting hardware is included (2-56 screws) to mount the circuit board, butterfly laser, and the clamp to a heat sink or cold plate.

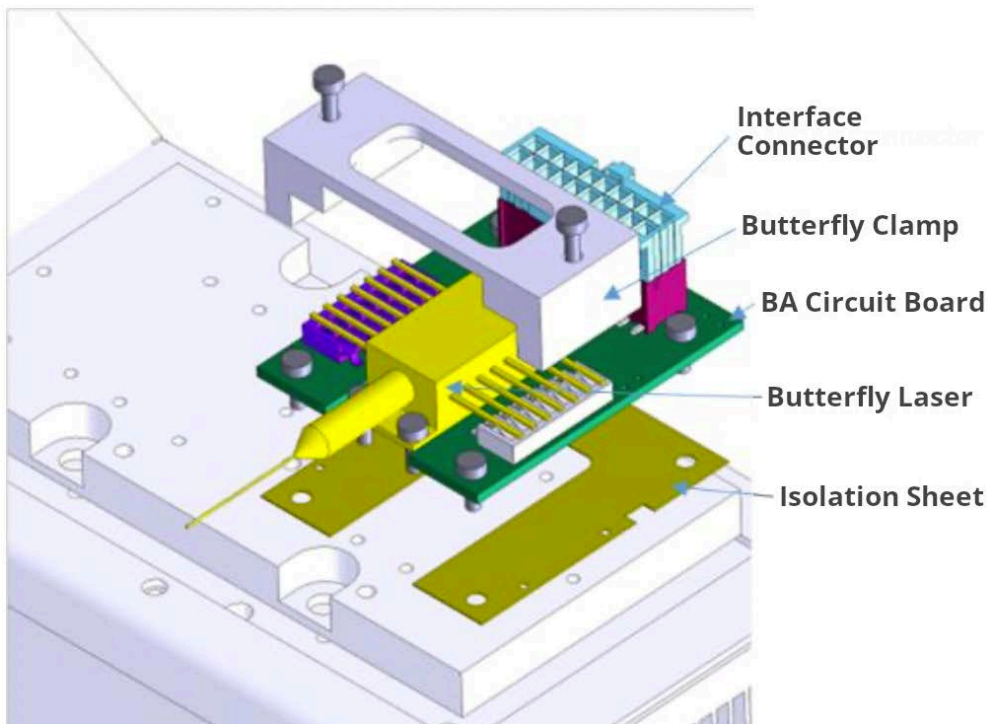

BA-02 Pin Configuration

The table below details the electrical connection of the BA-02 mount kit. The BA-02 kit allows butterfly lasers of any pin configuration to be used.

20 pin connector	Butterfly ZIF header	Plated holes for soldering wires	Rated current (A)
1	1		9
2	2		4
3	3		4
4	4		4
5	5		4
6	6		4
7	7		4
8	8		4
9	9		4
10	10		4
11	11		4
12	12 by shorting pin #2 & 4 of J7	J4 fan + w/pin# 2 & 4 of J7 open	4
13	13 by shorting pin#1 & 3 of J7	J4 fan - w/pin#1 & 3 of J7 open	4
14	14		9
15		J4 Cold plate fan +	5
16		J4 Cold plate fan -	5
17		J6 Cold plate thermistor	4
18		J6 Cold plate thermistor	4
19	1	J5 Cold plate TEC -	9
20	14	J5 Cold plate TEC -	9

The header on the BA-02 printed circuit board includes connections for the fan, thermistor, and TEC module on the OCP-050 heatsink assembly.

The connector for user interface is SAMTEC IPL-1-110-02-S-D, the mating connector is SAMTEC IPD1-10-D-K. SAMTEC offers value-add service for the related cable assembly.

BA-0X Dimensions

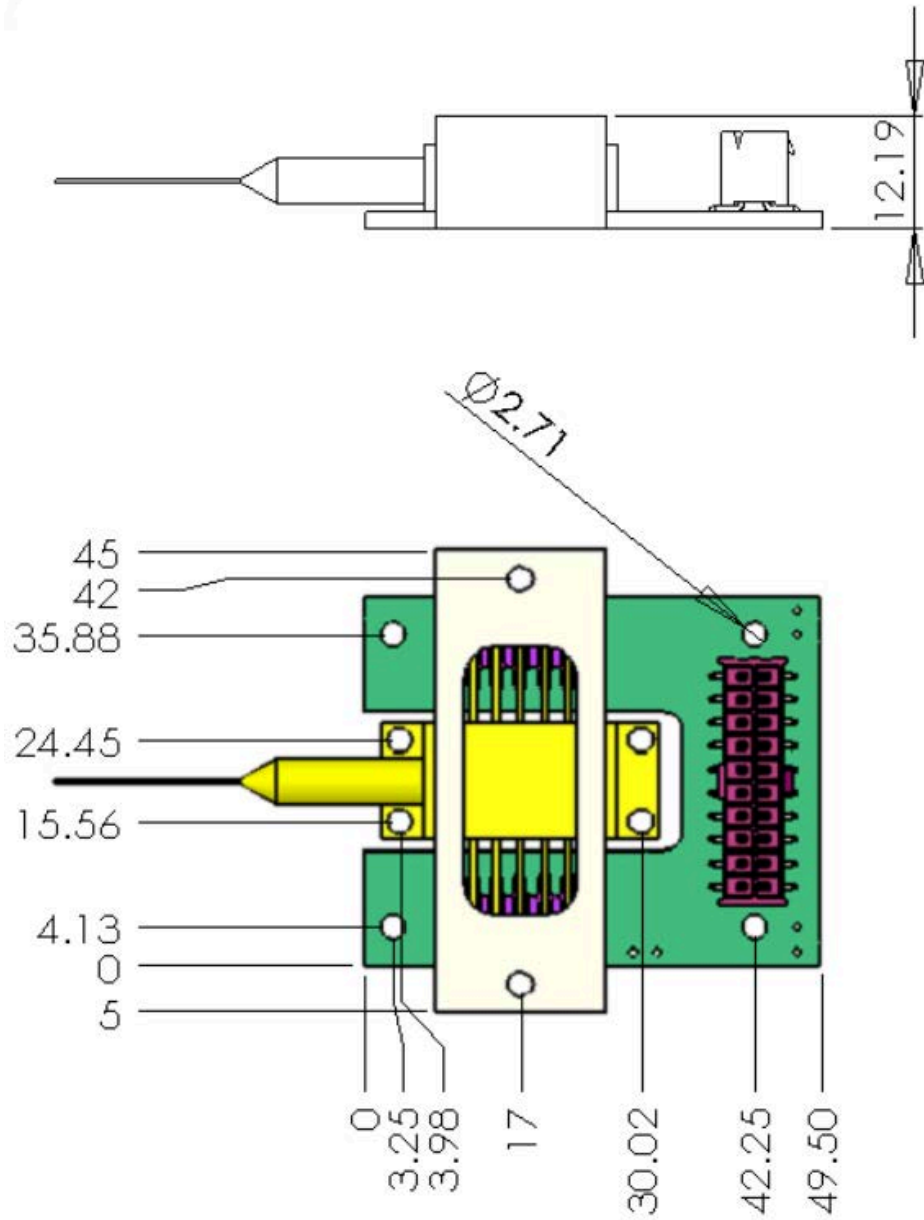

BA-0x mounting pattern (mm)

BA-01 Pin Configuration

The table below details the electrical connection of the BA-01 mount kit. Please note that only the butterfly packages that match the pin configuration listed below can be used with BA-01. Users are recommended to check the butterfly pinout carefully before making the connections. Butterflies that offer pin outs that differ from the table below should use BA-02.

20 pin connector	Butterfly ZIF header		Plated holes for soldering wires	Rated current (A)
1	5	thermistor		1
2	4	PD cathode -		1
3	3	PD anode +		1
4	2	thermistor		1
5	1	TEC +		6
6			J6 Cold plate thermistor	1
7			J6 Cold plate thermistor	1
8	14	TEC -		6
9	13	Case ground		1
10		N/C		1
11	11	Laser cathode -		4
12	11	Laser cathode -		4
13	10	Laser Anode +		4
14	10	Laser Anode +		4
15			J4 Cold plate fan +	1
16			J4 Cold plate fan -	1
17			J5 Cold plate TEC +	1
18			J5 Cold plate TEC +	1
19			J5 Cold plate TEC -	1
20			J5 Cold plate TEC -	1
	6, 7, 8, 9, 10, 12 Not connected			

The header on the BA-01 printed circuit board includes connections for the fan, thermistor, and TEC module on the OCP-050 heatsink assembly.

The connector for user interface is SAMTEC IPL-1-110-02-S-D, the mating connector is SAMTEC IPD1-10-D-K. SAMTEC offers value-add service for the related cable assembly.



LASER LAB SOURCE

world leading products for **Scientists & Engineers**

PRODUCT SALES AND SERVICE:

Orders for this product are fulfilled by LaserDiodeControl.com, part of the Laser Lab Source marketplace group. It is manufactured for sale on Laser Lab Source by elite thermal engineering.

PRODUCT WARRANTY:

This product is sold with a full one year warranty. It is warranted to be free from defects in material and/or workmanship for a period of one year from the date of shipment.



Laser Lab Source
670 S. Ferguson St., Suite 3
Bozeman, MT 59718 USA
800-887-5065
LaserLabSource.com

Elite Thermal Engineering
22914 11th Ave, W, Bothell, WA 98021
Phone: 425-770-8147
contact@elitethermalengineering.com