

EYP-MNT-0000-00000-0000-CLP01-9000

Revision 0.90 2013-08-26 page 1 of 3

ColdPack

TO-3 Adapter with integrated Thermoelectric Cooler



General Product Information

Product	Application
Mount for Thermal Control of Laser Diodes	Cooling
- with integrated Thermoelectric Cooler and Thermistor	Temperature Control
- for Laser Diodes with standard 9 mm (or 5.6 mm*) TO package	Wavelength Tuning
- Product does not include Laser Diode or Temperature Controller	
*) with optional TO-56 Adapter Ring (see Order Codes on p. 3)	

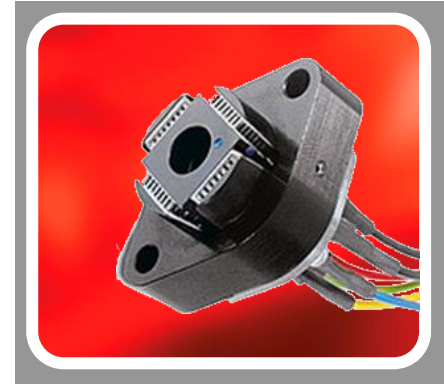

Characteristics

	Symbol	Unit	min	typ	max
Storage Temperature	T_S	°C	-40		85
Operational Temperature at Laser Case	T_{LD}	°C	0		50
Current	I_F	A			1.2
Voltage	V_R	V			17.2

Measurement Conditions / Comments

$T_{ColdPack\ case} = 25^\circ\text{C}$, heat load $Q_{max} = 11.2\text{ W}$

Stress in excess of the maximum ratings can cause permanent damage to the device

Thermistor (Standard NTC Type)

Parameter	Symbol	Unit	min	typ	max
Resistance	R_0	k Ω		10	
Beta Coefficient	β			3895	

Measurement Conditions / Comments

$R = R_0 \exp(\beta/T - \beta/T_0)$

Reference Temperature $T_0 = 298\text{ K}$

Typical Measurement Results

Temperature Scan

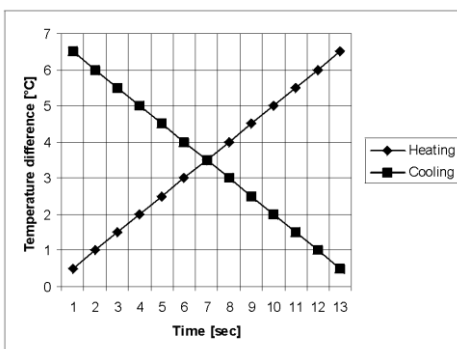

Temperature Response

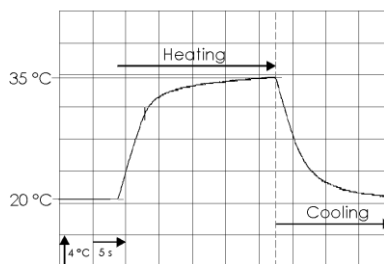

Performance figures, data and any illustrative material provided in this specification are typical and must be specifically confirmed in writing by eagleyard Photonics before they become applicable to any particular order or contract. In accordance with the eagleyard Photonics policy of continuous improvement specifications may change without notice.

EYP-MNT-0000-00000-0000-CLP01-9000

Revision 0.90

2013-08-26

page 2 of 3

ColdPack

TO-3 Adapter with integrated Thermolectric Cooler



Pin Assignment

- Pin 1 TEC (+)
- Pin 2 Thermistor 1
- Pin 3 Thermistor 2
- Pin 4 Laser Diode cathode (-)
- Pin 5 Laser Diode anode (+)
- Pin 6 Monitor Photodiode anode
- Pin 7 Monitor Photodiode cathode
- Pin 8 TEC (-)

Soldering Pads

- Pad 4J Laser Diode cathode (-)
- Pad 5J Laser Diode anode (+)
- Pad 6J Monitor Photodiode anode
- Pad 7J Monitor Photodiode cathode

Fixation of the Laser Diode ¹⁾

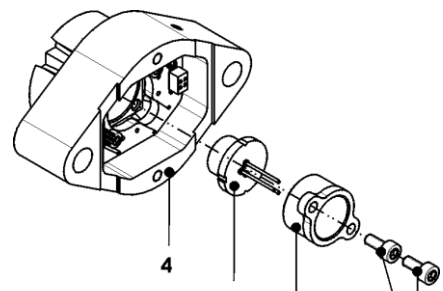

- 1 Screws
- 2 Ring
- 3 Laser Diode ¹⁾
- 4 ColdPack Mount

1) The ColdPack does not include a laser diode

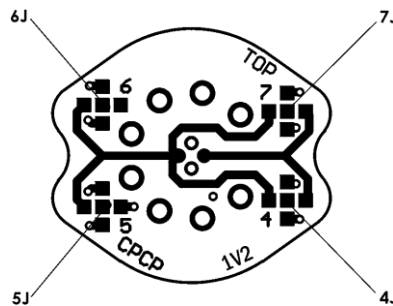
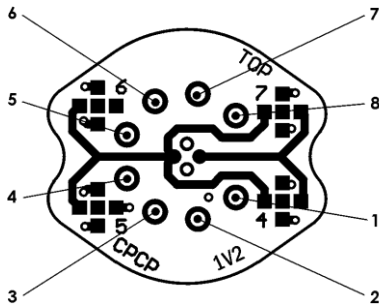

Package Drawings

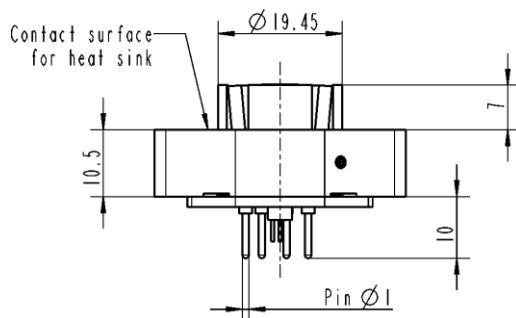
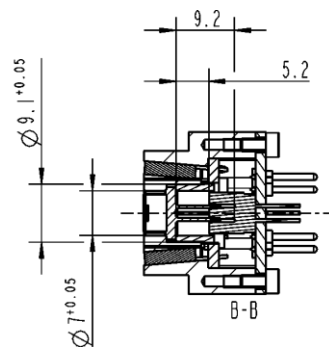
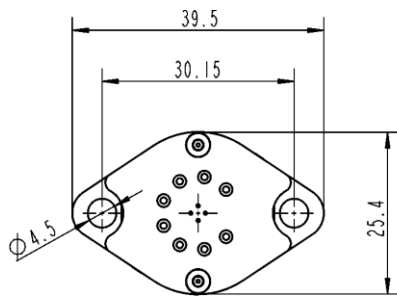

Fixation of the ColdPack Connector PCB

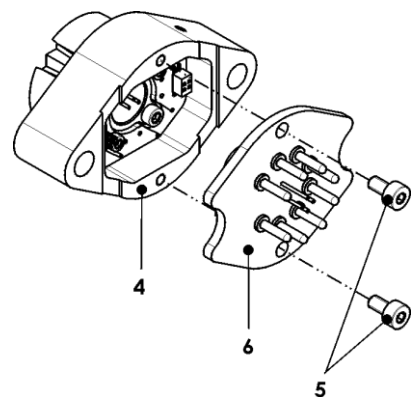

- 4 ColdPack Mount
- 5 Screws
- 6 Connector PCB

EYP-MNT-0000-00000-0000-CLP01-9000

Revision 0.90

2011-12-13

page 3 of 3

ColdPack

TO-3 Adapter with integrated
Thermoelectric Cooler



RWE/RWL

BAL

DFB/DBR

TPL/TPA

Product Content

Product

ColdPack Assembly (includes parts shown on p. 2 except the laser diode)

1 Set of Cables (Length: 210 mm)

2 Allen Screws (M2.5 x 16)

2 Allen Screws (M3 x 16)

2 Belleville Washers

2 Washers

Comment

can be used alternatively to the M2.5 screws

can be used alternatively to the M3 screws

Order Code Scheme

Product

ColdPack

Adapter Ring for Laser Diode 5.6 to 9 mm (optional)

Integration of Laser Diode into ColdPack (optional)

Order Code

EYP-MNT-0000-00000-0000-CLP01-9000

EYP-MNT-0000-00000-0000-CLP01-9020

EYP-MNT-0000-00000-0000-CLP01-9100