



*This product is sold
and supported
in the USA by*



LASER LAB SOURCE
marketplace for **Scientists & Engineers**

contact@LaserLabSoure.com

800.887.5065



Figure 1. Physical Photo of ATLS15A218D

FEATURES

- Wide Input Voltage Range: 5.5V ~ 25V
- Wide Output Voltage Range: 0.1V_{VPS} to 0.8V_{VPS} (input voltage)
- High Current Capability: 15A
- High Efficiency: ≥90%
($I_{OUT}=15A@V_{LDA}=20V\&V_{VPS}=25V$)
- Wide Modulation Bandwidth: DC ~ 10kHz
- Compact Size: 35.78×35.78×11.5 (mm)
- Dual Independent Current Set Ports: LISH and LISL
- Direct Digital Modulation Control: PCN
- Three Control States: Shutdown, Standby and Operation
- Low Output Current Noise: <12μA_{p-p}@0.1Hz~10Hz
- High Current Stability: <±20mA@15A&-20°C~80°C
- Low Output Ripple Voltage: <10mV@500kHz
- Fully Shielded
- 100 % Lead (Pb)-free and RoHS Compliant

APPLICATIONS

Drive one or multiple laser diodes for DPSSL, EDFA, and fiber lasers with low noise and high efficiency.

DESCRIPTION

This laser driver, ATLS15A218, is an electronic module that has all the valuable and important, but often difficult to achieve simultaneously, features: wide input and output voltage range, high output current capability, high efficiency, low output noise (but it has an output 10mV_{p-p} ripple voltage at 500kHz), wide modulation bandwidth, and small size. The wide output voltage range, 0.1V_{VPS} ~ 0.8V_{VPS}, allows driving one or multiple serial laser diodes at the same time,

for up to 15A well controlled current at high efficiency. The extremely low noise between DC ~ 10Hz and low DC current drift make it ideal for driving diode pumped laser diodes. Because of the high efficiency, the laser driver generates small amount of heat, thus, no heat sink is necessary for normal operation. The fully shielded case blocks all the incoming and outgoing EMIs (Electro-Magnet Interferences). Therefore, this laser will not interfere other surrounding electronics, nor will be interfered by them. The small package saves valuable PCB space in laser systems. Figure 1 shows physical photo of the ATLS15A218D.

This laser driver has two current set ports which can digitally be controlled to switch between them for setting the output current. This feature allows modulating the laser digitally with 2 preset current values.

The actual laser current and laser driver temperature are monitored by dedicated ports. In case the laser driver temperature exceeds the limit, 120°C, the laser driver will shut down the output stage by itself and force the laser drive into Standby Mode. There is a loop good indication output to tell if the laser driver works ok.

The laser driver has 3 states: Operation, Standby and Shutdown. Under Standby mode, all the laser driver components works except the output stage, see Figure 4. Under Shutdown mode, all the components of the laser driver stops working and the power supply current is reduced to < 3μA.

This laser driver generates a high accuracy high stability low noise, 12μA_{p-p}, <2μV_{RMS}, <20ppm/°C, 4.096V<±3mV, voltage reference output which can be used for setting the output current and also be used as the reference voltage for the ADCs (Analog to Digital Converters) and/or DACs (Digital to Analog Converters).

The ATLS15A218 uses a constant frequency high efficiency PWM output stage. Its switching signal is taken out through a buffer at the SYNO port, pin 10, which can be used by other switch mode electronics as the trigger signal to avoid frequency beating interference, if the free-run frequency is around 500kHz.

Warning: Both the surface mount and the through hole types of packages can only be soldered manually on the board by a solder iron of < 310°C (590°F), do not use a reflow oven to solder this laser driver.

For noise sensitive applications, please be aware that this laser driver has very low noise between DC to 10Hz, but some high ripple output voltage, a sine-wave, 10mV_{p-p}, at the switching frequency, 500kHz.

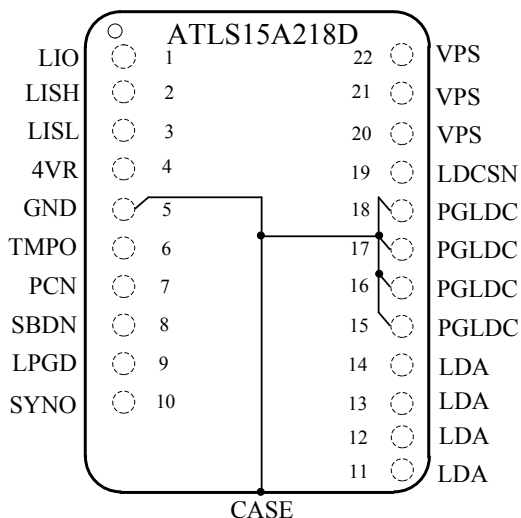

Figure 2 is the top view of the ATLS15A218, which also shows the pin names and locations. Its thickness is 4.5mm. The pin functions and specifications are described in Table 1 below. Note that the metal case is internally connected to ground.

Figure 2. Pin Names and Locations

Table 1. Pin Function Descriptions

Pin #	Name	Type	Description
1	LIO	Analog Output	Laser Current Output Indication. 0V to 4.096V indicates the laser current being from 0 to 15A linearly. The maximum sourcing current and sinking current of LIO is 40mA.
2	LISH	Analog Input	Laser Current High Value Setting Voltage. For this pin, everything is the same as above except that this pin sets the output current when PCN, pin 7 is high.
3	LISL	Analog Input	Laser Current Low Value Setting Voltage. There is a 10MΩ input resistor tied to GND. Setting it from 0V to 4.096V will set the laser lower current from 0 to 15A linearly. The current set by this pin can be higher than the current set by the LISH port on pin 2, the reason calling it "low" is because when PCN, pin 7, is low, the laser driver will output the current set by this pin. The input bias current of this pin is < 0.1μA, in addition to the 10MΩ resistor tied to GND. The maximum input voltage on this pin is 4.096V. It is recommended to use the 4VR port, pin 4, as the voltage source for setting the output current.
4	4VR	Analog Output	Voltage Reference 4.096V output. It can source and sink up to 10mA output current, with a very low 5μV _{P-P} noise between 0.1 to 10Hz and < 6ppm/°C stability. Under Standby Mode, this pin is still working.
5	GND	Signal Ground	Signal Ground Pin. Connect ADC and DAC grounds to here. When using POTs (potentiometer) to set the output currents, connect the ground terminal of the POTs to here. See Figure 6.
6	TMPO	Analog Output	Temperature Output Pin. This pin indicates the controller temperature. The relationship between the output voltage and the temperature is: $T = -1525.04 + 10^3 \sqrt{2.4182 + \frac{1.8015 - V_{TMO}}{3.479}} \text{ (}^\circ\text{C)} \quad (1)$ $\text{or, } V_{TMO} = 1.8015 - 3.479 \left[\left(\frac{T + 1525.04}{10^3} \right)^2 - 2.4182 \right] \quad (2)$ where V_{TMO} is the voltage on the TMO pin. This formula can be approximated by a linear equation with about 1% error between -40°C ~ 125°C: $T = 192.5576 - 90.1040 \times V_{TMO} \text{ (}^\circ\text{C)} \quad (3)$ $\text{or, } V_{TMO} = 2.1365 - 0.0111 \times T \text{ (}^\circ\text{C)} \quad (4)$



			The maximum output current of the TMO pin is 1uA.
7	PCN	Digital Input	Pulse Control Input. This pin toggles the laser output current to change between two pre-set values: a low value set by the LISL pin @ $V_{PCN} = 0V \sim 0.4V$ and a high value set by the LISH pin @ $V_{PCN} = 1.4V \sim 5V$. This PCN pin is pulled high to an internal 5V rail by an internal $1M\Omega$ resistor and there is a serial $20k\Omega$ resistor between PCN and the electronic switch, see Figure 3. Between $0V \sim 5V$, the pull up resistor causes most of the current on this pin, the electronic switch input current is $< \pm 1\mu A$. The maximum voltage on this pin is 28V, at which the pull down current will be caused by the serial $20k\Omega$ clamped by an over voltage protector of 5V, the current will be $(28V - 5V)/20k\Omega = 1.15mA$. The rise and fall time of the output is $28\mu S$ when PCN pin is switched.
8	SBDN	Analog/Digital Input	Standby and Shutdown Control. This pin has 3 regions: between $0V \sim 0.4V$, it shuts down the entire laser driver; between $2.1V \sim 2.4V$, it sets the laser driver to standby mode; between $2.6V \sim 15V$, it sets the laser driver to operation mode. The input current on this pin is $< 2\mu A$.
9	LPGD	Digital Output	Loop Good Indication. When the laser driver's output current equals to the set-point current value, and there is no short nor open circuit at the output, this pin is pulled up high by an internal $3k\Omega$ resistor to an internal 4.5V power supply as shown in Figure 3; when the output current is not equal to the set-point current, such as there is an open circuit at the output, or the load has too high a resistance that even the output voltage reaches the power supply voltage, the output current is still lower than the set-point value, this pin is pulled low by an open drain MOSFET of which $R_{dson} < 500\Omega$. When outputting the low value, the sinking capability is $< 0.5V$ at 1mA.
10	SYNO	Digital Output	Synchronization Output. This is a digital output signal with internal impedance of 100Ω by passed by 1.5MHz low pass filter. This output is triggered by the PWM output stage of this laser driver and can be used to synchronize other switch mode electronics to avoid the beating interference with their free-run frequencies if their free-run frequencies are close to 500kHz. If the free-run frequency of other electronics is far away from 500kHz, no need to use this pin.
11,12,13,14	LDA	Analog Output	Laser Diode Anode. Connect it to the laser diode anode terminal. The maximum current of this pin can go up to 15A. When doing layout, do not use a thin and long PCB track, otherwise, the inductance might be too high and oscillation may occur.
15,16,17,18	PGLDC	Power Input & Output	This pin has two functions: 1. Power Ground Pin. Connect this pin directly to power supply return path line, 0V. The maximum current on this pin can go up to 15A. 2. LDC Pin. Connect it to laser diode cathode terminal. The maximum current on this pin can go up to 15A.
19	LDCSN	Analog Output	Connect it to the laser diode cathode directly.
20,21,22,	VPS	Power Input	Power Supply Voltage. The driver works from $V_{VPS} = 5.5V \sim 25V$. The maximum current can go up to 15A.

**Table 2. Temperature vs. V_{TMO} (V) by Different Equations**

Temperature (°C)	V_{TMO} (V) by using a regional equation (2)	V_{TMO} (V) by using an approximating equation(4)
-40	2.5420	2.5811
0	2.1231	2.1371
25	1.8557	1.8596
40	1.6931	1.6931
80	1.2520	1.2491
100	1.0272	1.0271
125	0.7424	0.7496

SPECIFICATIONS

Table 3. Characteristics ($T_{AMBIENT}= 25^{\circ}C$)

Parameter	Symbol	Conditions	Min.	Typ.	Max.	Units
Power Supply Input: VPS pin, pin 20~22						
Input Range	V_{VPS}		5.5		25	V
Output current	A		0		15	A
Laser Current Setting Voltage: LISL pin and LISH pin, pin 3&2						
Laser current control signal			0		4.096	V
Control accuracy				± 0.1		%
Laser Current Output indication: LIO pin, pin 1						
Laser current indication signal			0		4.096	V
Indication accuracy				± 0.2		%
Voltage Reference: 4VR pin, pin 4						
Reference output voltage			3.996	4	4.004	V
Laser Diode Anode: LDA pin, pin 11~14						
Output voltage range		Frequency is 500kHz	$0.1V_{VPS}$		$0.8V_{VPS}$	
Standby and Shutdown Control: SBDN pin, pin 8						
Start-up time upon releasing the SBDN pin above 2.7V				20		ms
Shutdown time upon pulling the SBDN pin down				20		μs
Power efficiency		$I_{OUT}= 15A, V_{LDA}= 20V$ & $V_{VPS}= 25V$		90		%
Low frequency output current noise		Peak-to-peak value, 0.1Hz to 10Hz		<12		μA_{P-P}



Stability	15A & -20°C ~ 80°C	<±0.2	%
	15A & -20°C ~ 80°C	<±20	mA
Standby current		8	mA
Shutdown current		<2	µA
Operating case temperature		-40 ~ 110	°C
Operating ambient temperature		-40 ~ 85	°C

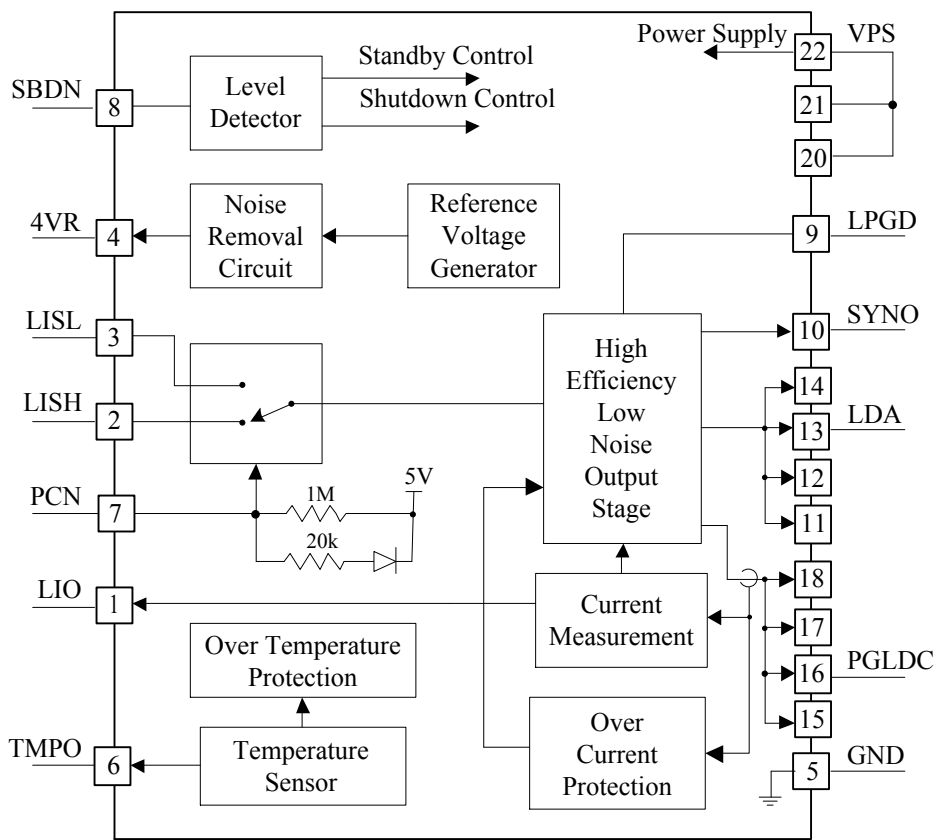

Figure 3. Internal Block Diagram of ATLS15A218



OPERATION PRINCIPLE

The block diagram of the driver is shown in Figure 3. The signal from pin 8, SBDN, is sent to a level detector circuit. As shown in Figure 4, upon detecting signal level between 0V to 2V, the shutdown output is activated; it shuts down the whole laser driver and drives the laser driver into Shutdown Mode; upon detecting the level to be between 2.2V and 2.4V, the standby signal is activated, it put the controller into Standby Mode; when the signal is between 2.7V and above, the controller is driven to Operation Mode.

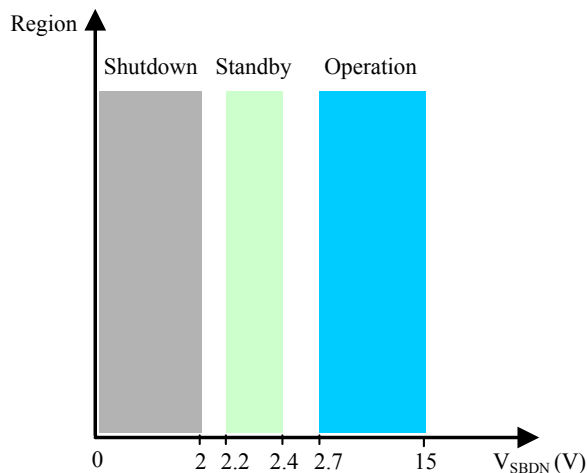

Figure 4. Input Control

At pin 6, TMPO, its value comes from a temperature sensor. The voltage at this pin reflects the internal temperature of this driver. The relationship between the output voltage and the temperature is shown in Figure 5.

There is a temperature protection circuit, upon detecting the temperature to be >120°C, it will force the laser driver into Standby Mode. The laser driver reinitiates the power up sequence when the junction temperature drops below 110°C.

The voltage reference circuit provides internal voltage reference for the driver, its output is taken out after a noise removal circuit at 4VR port, pin 4.

At pin 3 and pin 2, there are 2 ports for controlling the output current: LISL and LISH. The former sets the output current when PCN, Pulse Control, pin 7, is at low level, 0V to 0.4V; the latter sets the output current when PCN pin is at high level, 1.4V to 15V.

On PCN, pin 7, there is a 10M resistor tied to 5V. Therefore, if leaving this pin open, it is set to 5V, a high logic level, thus, LISH is in control. There is a 20kΩ resistor in series with a diode, connected between PCN pin and the 5V internal voltage. When the PCN pin voltage is above 5V, the 20kΩ resistor pulls down the current on PCN pin. The circuit is shown at Figure 3. The waveforms of LISH, LISL, PCN and LIO are shown in Figure 6.

Both LISH and LISL pin set the output current without any offset voltage. The relationship between the voltage and the output current is:

$$I_{OUT} = V_{LISH} / 4.096 \times 15 \text{ (A)} = 3.662 \times V_{LISH} \text{ (A)}, \text{ or}$$

$$I_{OUT} = V_{LISL} / 4.096 \times 15 \text{ (A)} = 3.662 \times V_{LISL} \text{ (A)};$$

$$V_{LISH} = I_{OUT} \text{ (A)} / 15 \times 4.096 = 0.273 \times I_{OUT} \text{ (A)}, \text{ or}$$

$$V_{LISL} = I_{OUT} \text{ (A)} / 15 \times 4.096 = 0.273 \times I_{OUT} \text{ (A)},$$

Where I_{OUT} is the output current of the laser driver, V_{LISH} or V_{LISL} represents the voltage on the LISH or LISL pin respectively, in volt.

The LIO port, pin 1, outputs an analog voltage that is proportional to the actual output current. When the output current is 0A, the LIO voltage is 0.1V; when output current is 15A, the LIO voltage is 2.5V. The relationship is:

$$V_{LIO} = I_{OUT} \text{ (A)} / 15 \times 4.096 = 0.273 \times I_{OUT} \text{ (A)};$$

$$I_{OUT} = V_{LISL} / 4.096 \times 15 \text{ (A)} = 3.662 \times V_{LISL} \text{ (A)};$$

V_{LIO} is the voltage on the LIO pin.

The waveform of LIO vs. LISH, LISL and PCN is shown in Figure 9.

The output stage is designed to achieve low noise, high efficiency, and relatively high modulation speed. It has an over current protection circuit. There is a soft start circuit which increases the output current slowly at the start up time and shuts down the current quickly.

The LPGD pin indicates the control loop status. When this pin goes high, >2V, the control loop is working properly, i.e., the output current equals to the desired value, LISH or LISL = LIO voltage; when this pin goes low, <0.3V, the laser driver is not working properly, there might be a short or open circuit at the output, or the laser driver is protected by the over temperature protection circuit.

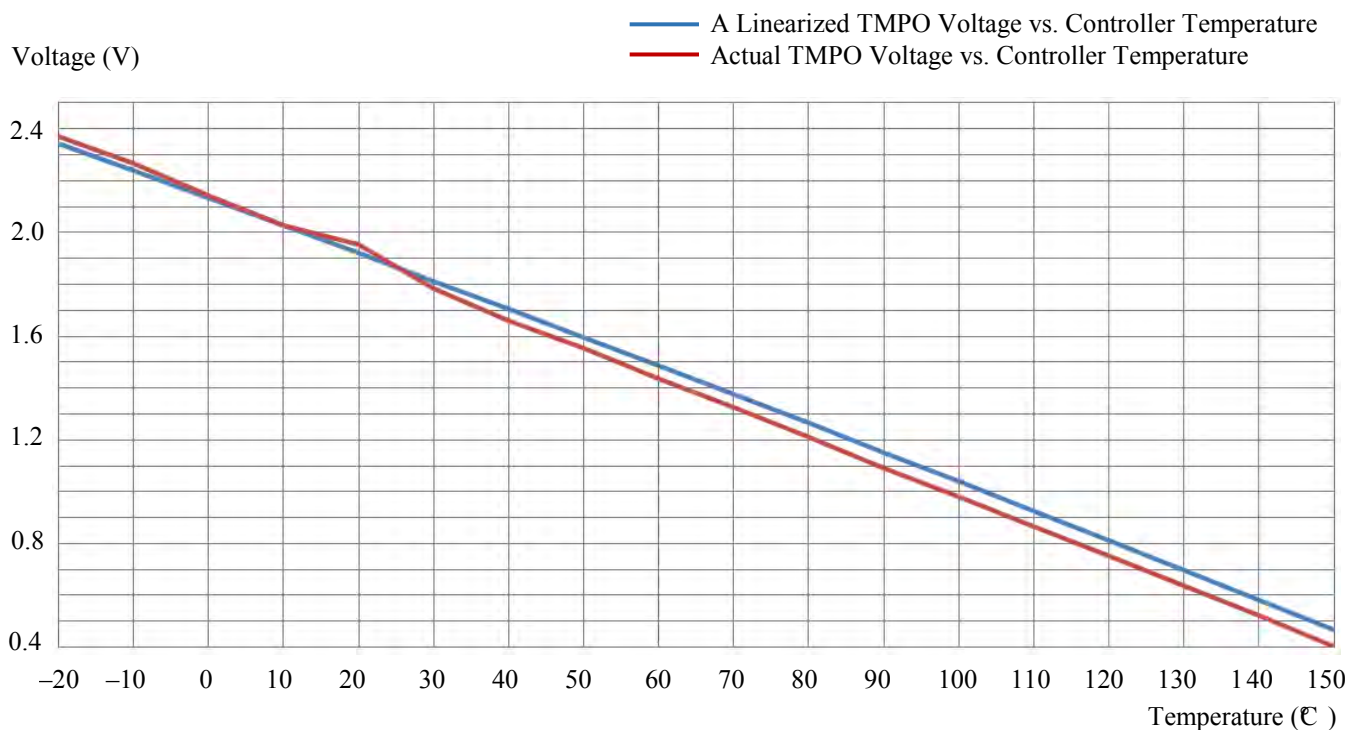

Figure 5. Controller Internal Temperature vs. TMPO Voltage

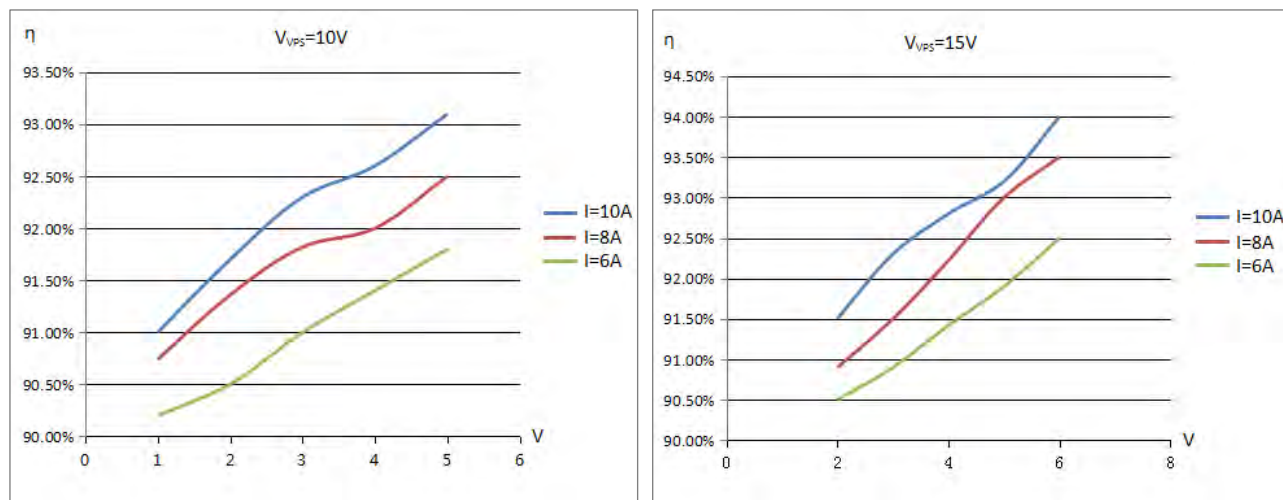

Figure 6. Efficiency of Laser Driver



APPLICATION INFORMATION

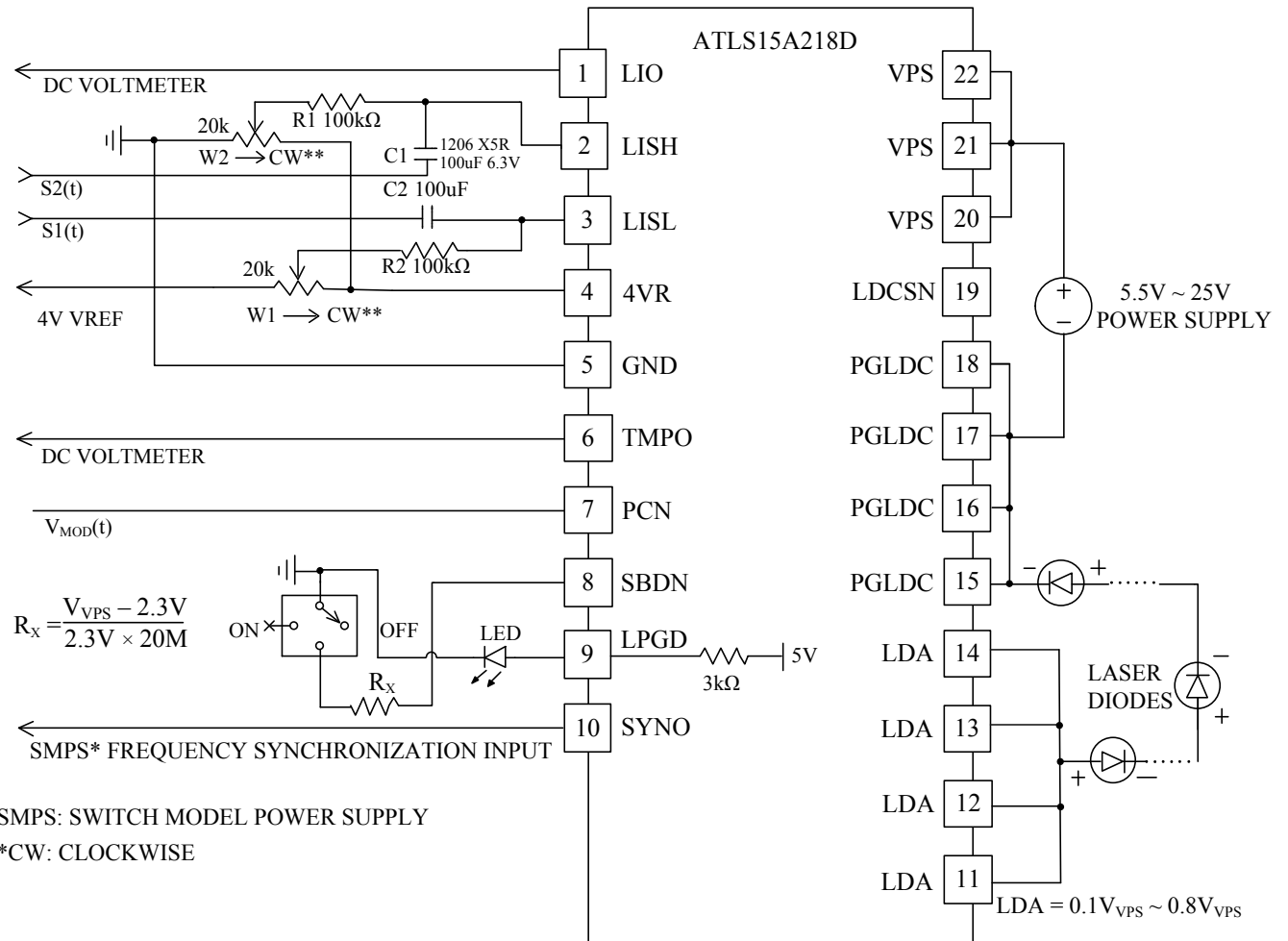

Figure 7. Stand-Alone Application Schematic

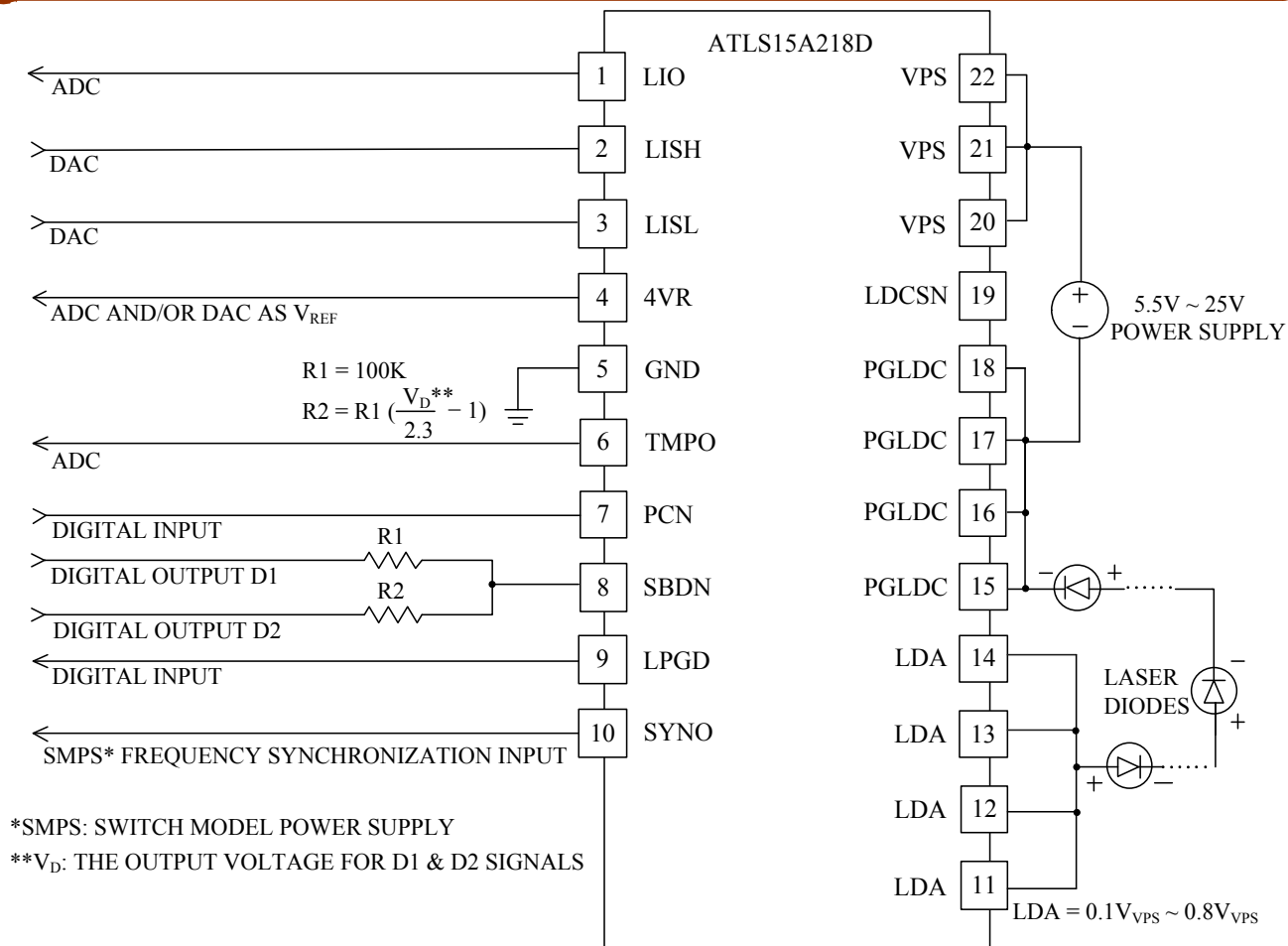

Figure 8. Micro-Controller Based Application Schematic

Figure 7 shows a typical stand-alone application circuit. Figure 8 shows a micro-controller based application schematic.

Table 4 shows the relationship between Digital D1, D2, and laser driver state. Refer to Figure 8.

Table 4.

Digital Output D1	Digital Output D2	Laser Driver State
0	0	Shutdown
0	1	Standby
1	0	Note
1	1	Operation

Note: For the input state D1=1 and D2=0, the controller's state is depending on the output voltage at SBDN pin:

$$V_{SBDN10} = \frac{R2}{R1 + R2} \times V_D$$

$$V_{SBDN01} = \frac{R1}{R1 + R2} \times V_D$$

Where, V_D is the logic1 output voltage for D1 & D2 signals.

Digital signal V1 and V2 control the laser driver into Shutdown, Standby or Operation mode. The starting up time delay is about 20mS and the shut down time is about 20µS.

It is worth mentioning that to achieve high speed and low distortion digital modulation, one can use the LISL pin to set a current that is a little lower than the threshold current of the laser diode to turn off the laser beam, such as half of its value, use the LISH pin to set the laser current when the laser diode is turned on. In this way, the laser beam is turned on and off, while the driver control loop is always kept on, so that the output stage is always under control, not distortion is caused by turning on/off the output stage.

When no modulation is needed, one can leave PCN unconnected; LISL pin connects to GND, and use LISH to set the output current.

In Figure 7, the LED is used to indicate laser diode status. When LDGD pin is high, > 2V, the laser diode control loop is working properly. When LPGD pin is low, <0.3V, the laser



diode control loop is not working properly, there might be a short or open circuit at the laser diode, or the laser driver is put into Standby or Shutdown mode. The LPGD pin can also be connected to a digital input pin of a micro-driver, when software/firmware is utilized in the system. See Figure 6. The equivalent circuit of this pin is a 3kΩ resistor pulling it up to 4.5V rail and an open drain FET, 500Ω, pulling it down to the ground. The pull-up current can be increased by connecting an external pull-up resistor between LPGD and

VPS. Tie this added additional pull up resistor to a 3.3V or 5V power supply if they are available. Make sure that the pull up current is not too high, otherwise, the internal open drain FET cannot pull-down the LPGD pin low enough to turn off the LED.

The laser diodes are connected between LDA and LDC pins. It is worth mentioning that the power supply return terminal should be connected to the pin 17 PGLDC.

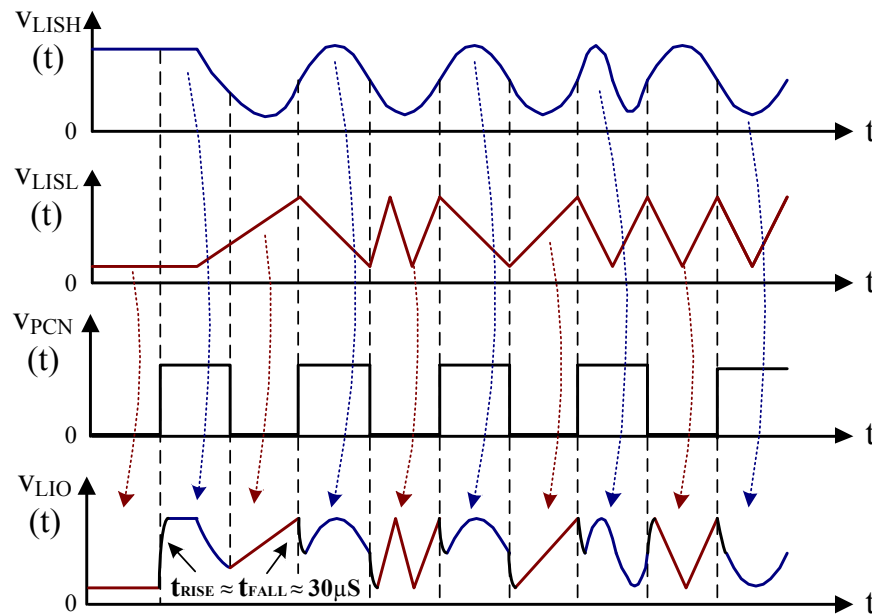

Figure 9. Digitally Controlled Analog Modulation Principle

Minimizing the Output Noise

The ATLS15A218 has extremely low output noise; care must be taken in using this laser driver to achieve this lower noise performance. One of the noise sources is the beating frequency interference from other power mode electronics, such as another laser driver, TEC (Thermo-Electric Cooler) controller, or power supply. There are 2 ways to avoid the frequency beating: set the switching frequencies of other electronics to be far away from the switching frequency of the laser driver, 700kHz, or synchronize the other electronics switching with this laser driver. For this purpose, there is a SYNO pin, which can be used by other electronics as the switching trigger signal.

The driver can be turned on and off by setting the SDBN pin high and low respectively. It is recommended to turn the driver on by this sequence:

To turn on: turn on the power by providing the power supply voltage to the driver on VPS pin, turn on the driver by releasing the SDBN pin.

To turn off: turn off the driver by lowering the voltage of SDBN pin, turn off the power by stopping the voltage supply on the VPS pin.

When not controlling by the SDBN pin: leave it

unconnected and turn on and off the driver by the power supply.

Adjusting the Output Current

The output current is set by adjusting W1, which sets input voltages of LISL and LISH, pin 3 and 2. See Figure 6. The output current will be:

$$I_{OUT} = 3.662 \times V_{LISL} \text{ or } 3.662 \times V_{LISH} \text{ (A)}$$

LIS can also be set by using a DAC to replace the W1 in Figure 7. Make sure that the DAC has low output noise.

Monitoring the Output Current

The output current of the driver can be monitored by measuring the voltage on the LIO pin. This feature is very useful for micro-driver based system where the ADC is available and monitoring the current in real time is required. This pin provides a very low noise voltage signal and is proportional to the output current:

$$I_{OUT} = 3.662 \times V_{LIO} \text{ (A)}$$

For example, when the output signal is 4.096V, the output current is 15A.

LIO can be used to drive an ADC directly, and also be measured by a multi-meter.



Driver Power Consumption

The best way for arranging the heat sinking for the driver is as follows: transferring the heat by sandwiching a piece of thermal conductive pad between the top metal surface of the laser driver and the internal metal surface of the final

product as shown in Figure 13.1 and 13.2 below. The recommended thickness of the thermal conductive pad in Figure 13.1 is 1~4mm, and in Figure 13.2 is 0.5mm. ATI also provides a series of thermal conductive pads, click [here](#) for more information.

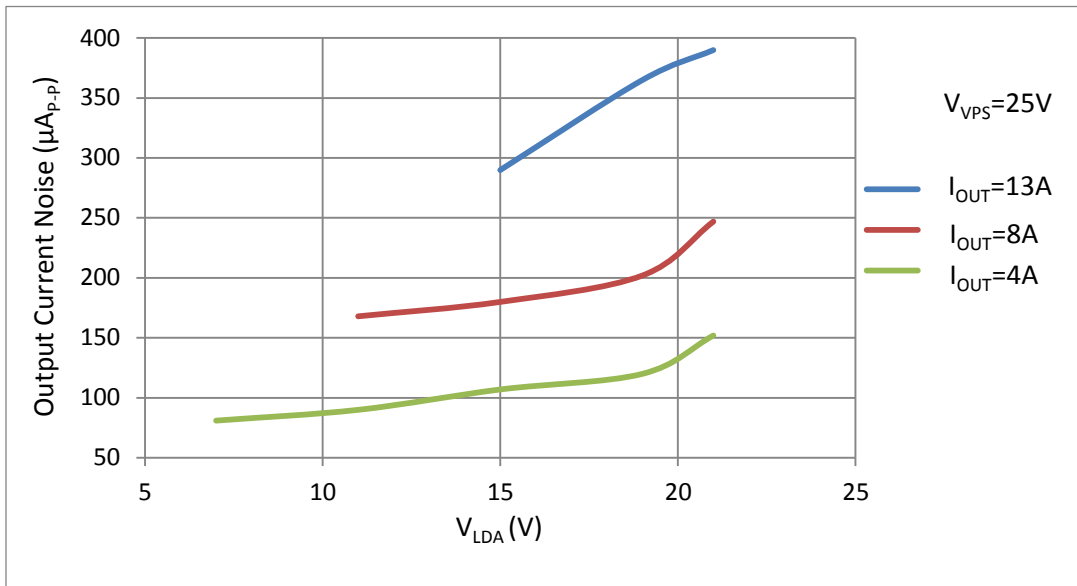

Figure 10. V_{LDA} vs. Output Current Noise@0.1Hz~10Hz

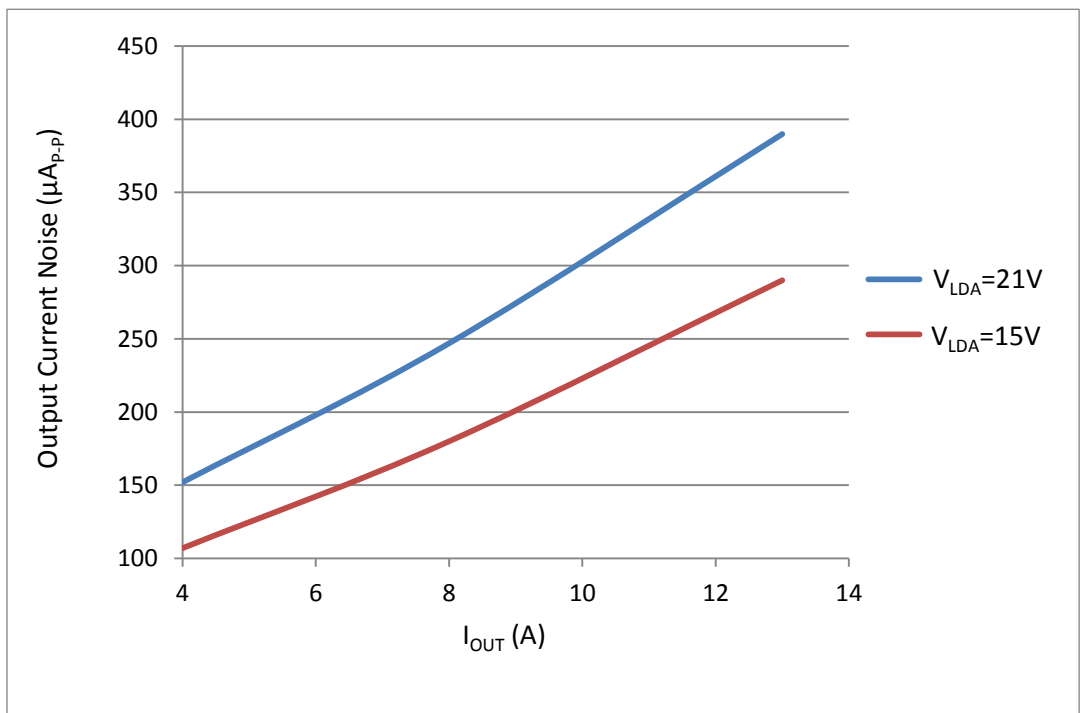

Figure 11. I_{OUT} vs. Output Current Noise@0.1Hz~10Hz

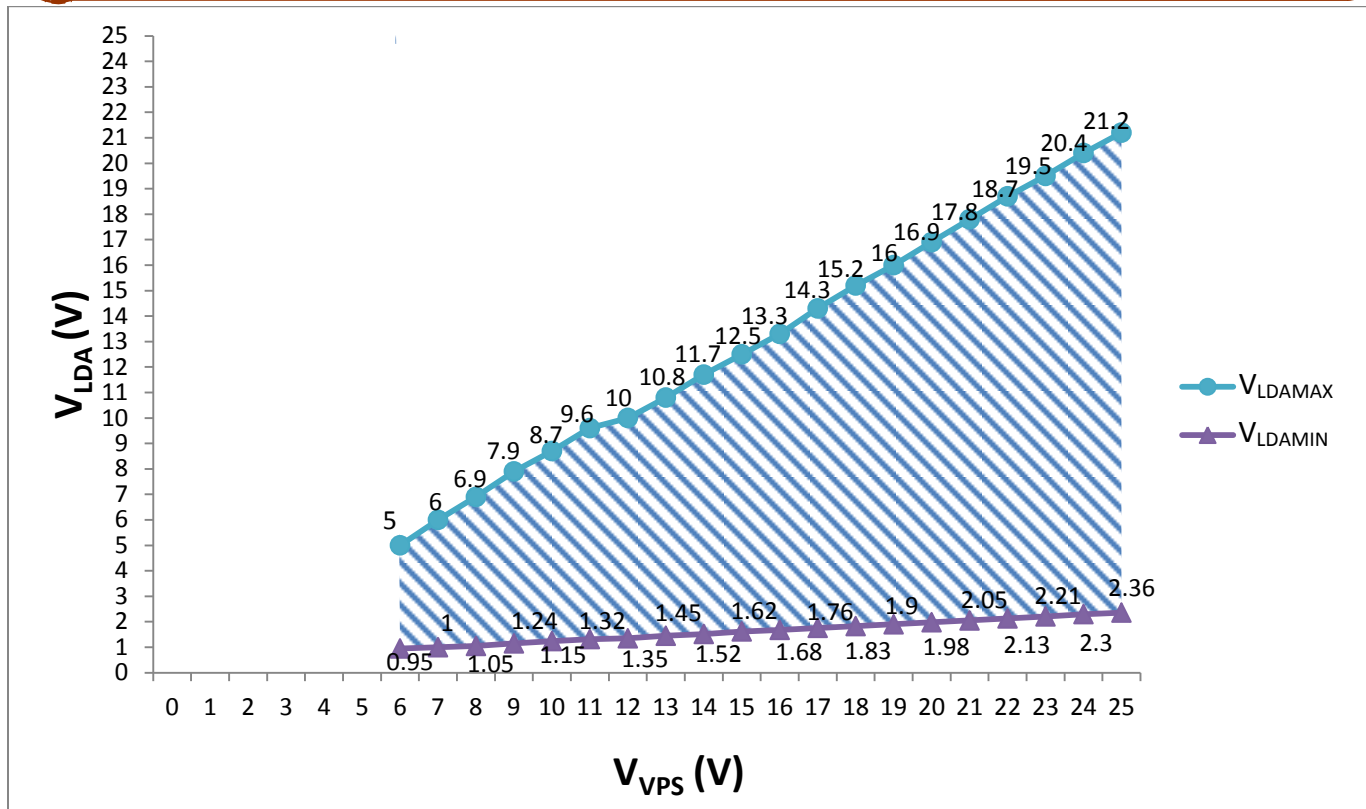

Figure 12. V_{VPS} vs. V_{LDA}

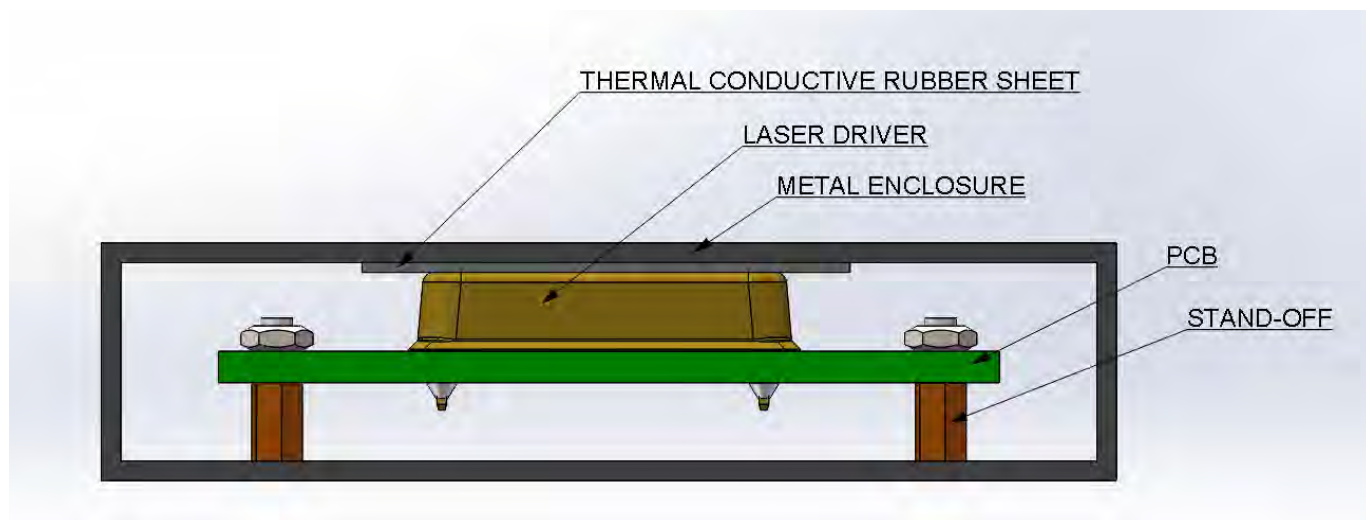

Figure 13.1 Transferring Heat with Metal Enclosure

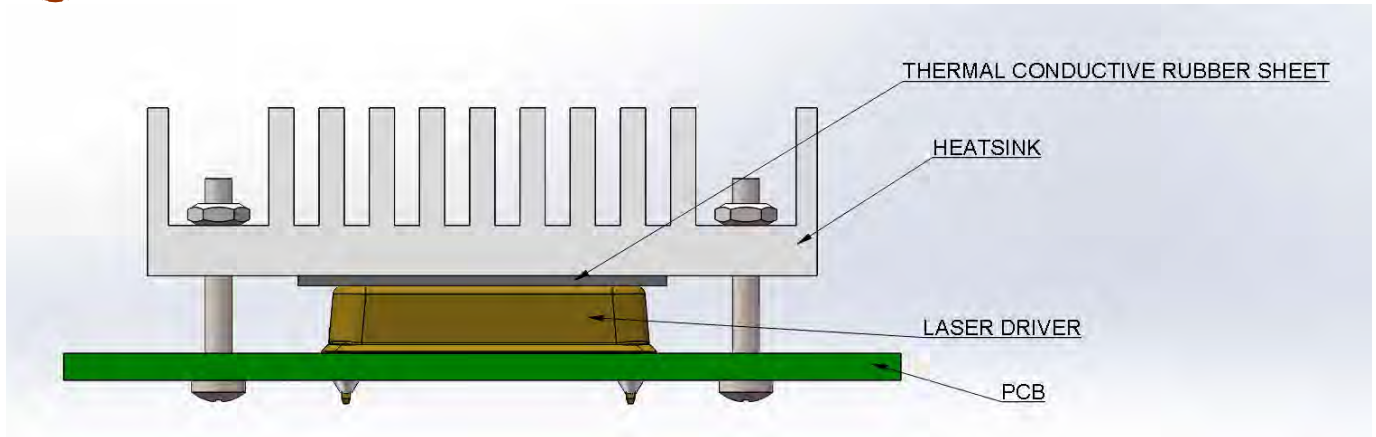

Figure 13.2 Transferring Heat with Heat Sink

First Time Power Up

Laser diode is a high value and vulnerable device. Faults in connections and damages done to the driver during soldering process may damage the laser diode permanently. To protect the laser diode, it is highly recommend to use 3 to 18 regular diodes which is >15A to form a “dummy laser” and insert it in the place of the real laser diode, when powering up the driver for the first time. Use an oscilloscope to monitor the LDA voltage at times of powering up and enabling the shutdown pin, and powering down the laser driver and turning off the shutdown pin, and make sure that there is not over-shoot output voltage at the LDA pin. At the same time, it uses an ammeter in serious

with the dummy laser, to make sure that the output current is correct. After thoroughly checking and making sure of free of faults in the system, disconnect the dummy laser diode and connect the real laser diode in place. The driver output voltage range for the laser is between 0.1V_{VPS}to 0.8V_{VPS} (power supply input voltage).

Warning: Both the surface mount and the through hole types of packages can only be soldered manually on the board by a solder iron of < 310°C (590°F), do not use a reflow oven to solder this laser driver.

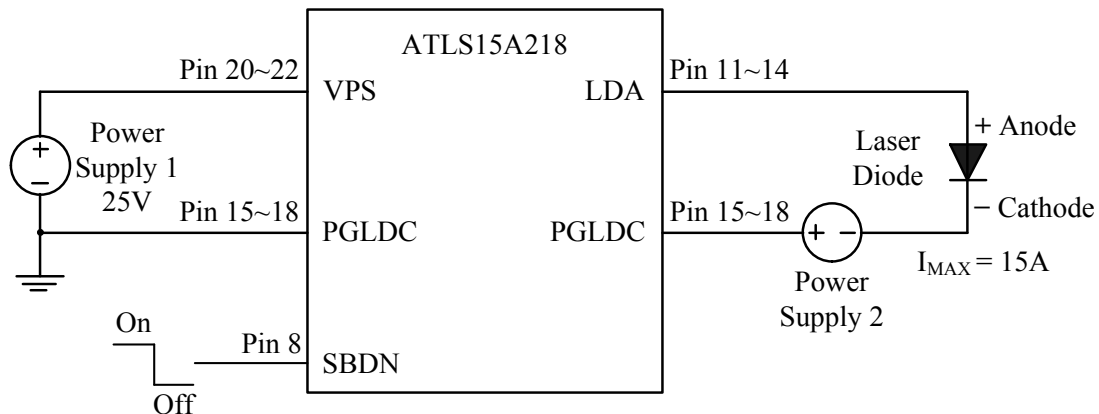

Figure 14. Driving High Voltage Laser Diodes

Warning: To turn on the laser, firstly turn on Power Supply 2 and Power Supply 1 while keeping SBDN=0, after >=100mS, then turn on the laser driver ATLS15A218 by using the SBDN pin. To turn off the laser, firstly turn off the laser driver ATLS15A218 by driving the SBDN pin to Standby or Off State, then turn off the Power Supply 2 and 1.



NOTE: The power supplies may have over-shoot voltage spikes when they are not connected well with the load or when they recover from an over current protection state. When happens, it may exceed the maximum allowed input voltage, 28V, of the controller and damage the controller permanently. To avoid this from happening, do the following:

1. Connect the controller well with the power supply before turning on the power.
2. Make sure that the power supply has sufficient output current. It is suggested that the power supply can supply 1.2 to 1.5 times the maximum current the controller requires.

3. When using a bench top power supply, set the current limit to >1.5 times higher than the maximum current the controller requires.
4. If the PCB is for mounting the laser driver. See the figures below for the layout of PGLDC pin. If the PCB has two layers, the top layer (red) is for routing PGND track, and the bottom one (blue) is for routing LDC track, see Figure 15. If the PCB has four layers, the top two layers are for routing PGND track, and the bottom two layers are for routing LDC track. The section views for two-layer and four-layer PCB's are shown in Figure16 and Figure 17 respectively.

If the PCB has one layer, see Figure 18 for the layout of PGND pin.

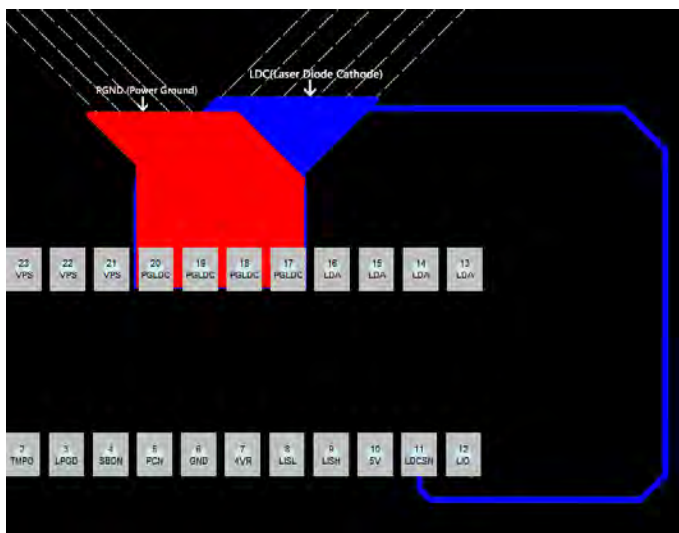

Figure 15. The Layout for the Two-Layer PCB

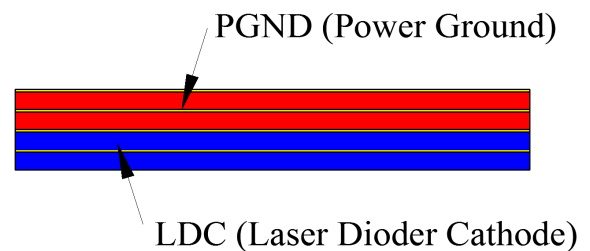

Figure 17. The Section View for the Four-Layer PCB

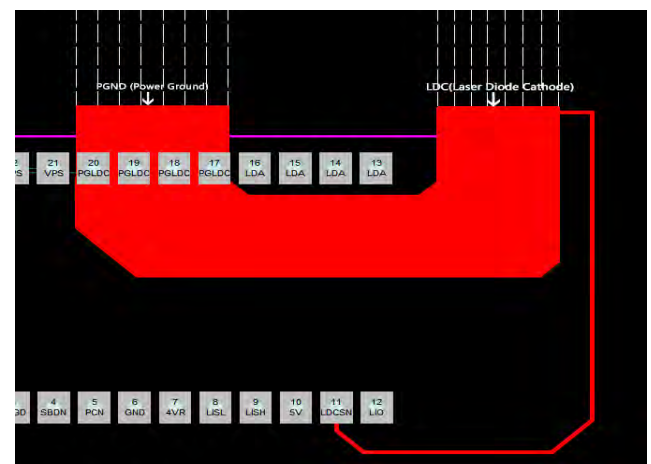

Figure 18. The Layout for the Single-Layer PCB

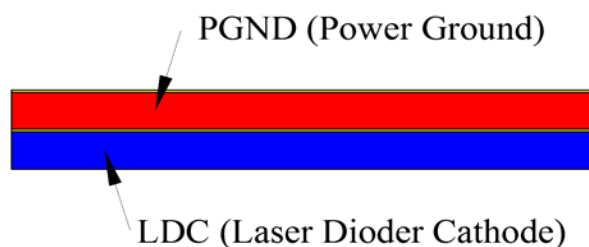

Figure 16. The Section View for the Two-Layer PCB



OUTLINE DIMENSIONS

The driver comes in 1 package: through hole mount, or so-called DIP (Dual Inline Package) or D (short for DIP) package.

Dimensions of the DIP package driver are shown in Figure 19.

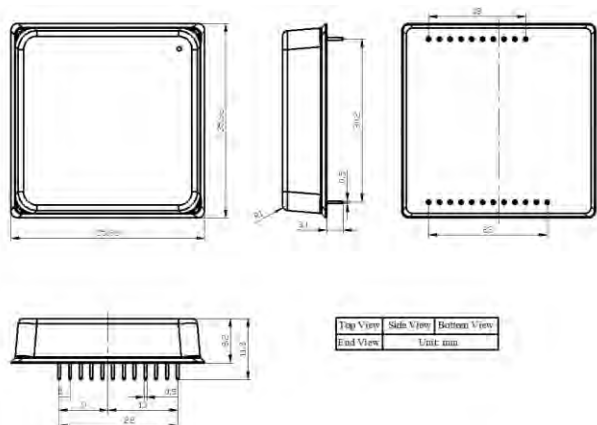

Figure 19. Dimensions of the DIP Package Driver

Figure 20 shows the foot-print which is seen from the end side of the PCB.

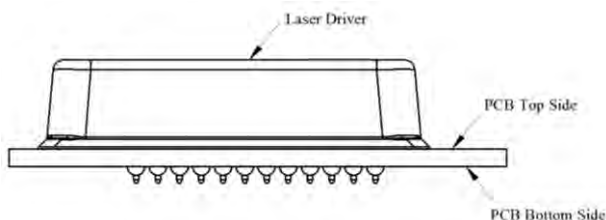

Figure 20. End View of the PCB Foot-print

“Tent” all the vias under the driver, i.e. cover the entire via by the solder mask layer, otherwise the vias can be shorted by the bottom plate of the driver which is internally connected the ground.

See Figures 19, it is recommended to use large copper fills for VPS, PGLDC, and the LDA pins, and other pins if

possible, to decrease the thermal resistance between the module and the supporting PCB, to lower the module temperature.

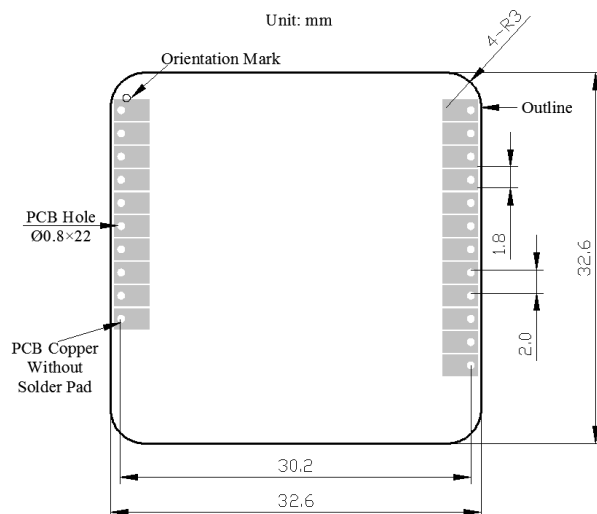

Figure 21. Top View of the Top Side PCB Foot-print

Figure 21 shows the foot-print which is seen from the top side of the PCB, therefore, it is a vertical view.

It is highly recommended to lower solder iron temperature to 310°C (590°F) and solder the driver manually, so that the internal contents of the driver would not be affected.

After the soldering, it is also safe to check the laser driver’s functionality by using the “dummy laser” before connecting a real laser diode as mentioned previously on page 4.



ORDERING INFORMATION

Table 5. Part Number

Part Number	Description
ATLS15A218D	15A constant current driver in DIP package

Table 6. Unit Price

Quantity (pcs)	1 – 9	10 – 49	50 – 199	200 –499	≥500
Unit Price	\$159	\$150	\$145	\$139	\$135

NOTICE

- ATI warrants performance of its products for one year to the specifications applicable at the time of sale, except for those being damaged by excessive abuse. Products found not meeting the specifications within one year from the date of sale can be exchanged free of charge.
- ATI reserves the right to make changes to its products or to discontinue any product or service without notice, and advise customers to obtain the latest version of relevant information to verify, before placing orders, that information being relied on is current and complete.
- All products are sold subject to the terms and conditions of sale supplied at the time of order acknowledgment, including those pertaining to warranty, patent infringement, and limitation of liability. Testing and other quality control techniques are utilized to the extent ATI deems necessary to support this warranty. Specific testing of all parameters of each device is not necessarily performed, except those mandated by government requirements.
- Customers are responsible for their applications using ATI components. In order to minimize risks associated with the customers’ applications, adequate design and operating safeguards must be provided by the customers to minimize inherent or procedural hazards. ATI assumes no liability for applications assistance or customer product design.
- ATI does not warrant or represent that any license, either express or implied, is granted under any patent right, copyright, mask work right, or other intellectual property right of ATI covering or relating to any combination, machine, or process in which such products or services might be or are used. ATI’s publication of information regarding any third party’s products or services does not constitute ATI’s approval, warranty or endorsement thereof.
- IP (Intellectual Property) Ownership: ATI retains the ownership of full rights for special technologies and/or techniques embedded in its products, the designs for mechanics, optics, plus all modifications, improvements, and inventions made by ATI for its products and/or projects.