



3.5 Amp Pulsed Laser Diode Driver with TEC Controller and Butterfly Mounting Socket



CCS-HP / Control and Mount Module

- o User Set Pulse Widths from 1.5 ns to CW
- o 0 to 3.5 Amps Output Current
- o 1 Hz to 10 MHz Repetition Rate
(250 MHz Available, refer to options)
- o Integrated Pre-Configured Butterfly Mounting
Socket & TEC Temperature Controller
- o Models Available for Type 1 and Type 2
Butterfly Laser Pin Configurations
- o Built-In Pulse Generator or Remotely Triggered
- o USB Interface, Includes Programming Tools
Software Suite, DLL Library and GUI



PRECISION PULSED DRIVER FOR SEED PUMPING AND SENSING APPLICATIONS

Designed for precision seed pumping and sensing applications, these laser diode pulse control electronics and mounting modules are optimized for single-shot to CW performance with pulse width lengths as narrow as 1 nanoseconds. These complete control and mounting modules deliver precision pulses which are generated internally by an on-board pulse generator, or on demand from your external TTL signal generator.

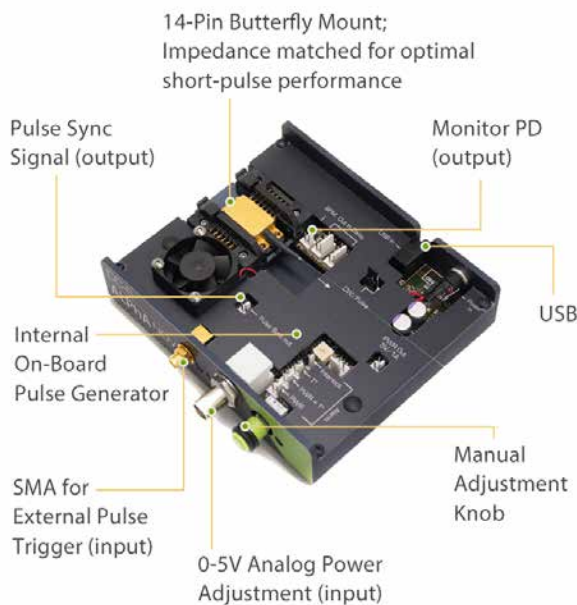

These pulse drivers offer integrated laser diode protection to ensure that your laser is protected at all times. They include an efficient TEC controller which keeps the device under test delivering a highly stable output and protects it from thermal damage. A USB interface and graphical user interface offers the user complete control of the pulsing parameters. The user has control of amplitude, pulse width, rep. rate, temperature set point, current / temperature limits and more.

FLEXIBLE LASER DIODE PULSE GENERATION AND OUTPUT SYNCHRONIZATION

These drivers offer the user the flexibility to choose from three different pulse generation sources. First, they include an internal pulse generator. Second, the user can choose to use an external trigger source. Finally, an external trigger source can be used to activate the internal pulse generator. If the user chooses to provide an external trigger source, the input pulse trigger is a TTL/LVTTL input voltage through an SMA connector. The input voltage range for the external trigger is 0 ~ 3.3 Volts. These units also provide the user with a sync-out port which allows synchronization of the driver to related test equipment. This SMA output port delivers an LVTTTL copy of the CC-S logical driving signal.

CLEAN HIGH SPEED PULSE PERFORMANCE

Matching the impedance of the butterfly packaged laser diode load to the impedance of the current source transmission path improves the quality of the laser diode pulse shape.

CCS IMPEDANCE MATCHING PROVIDES CLEAN PULSE PERFORMANCE

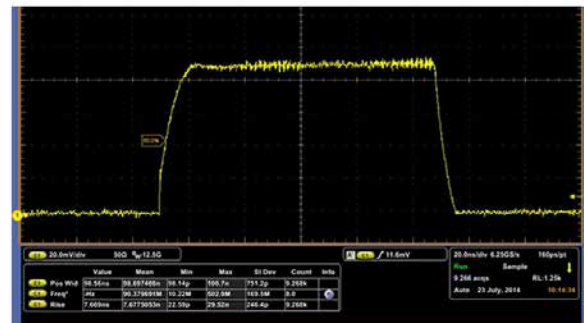



PIN CONFIGURATIONS

The CCS-HP can be ordered for any butterfly package pin configuration. Because impedance matching is a critical factor in delivering clean high speed pulse performance, the CCS-HP unit is pre-set for your laser diode's pin configuration.

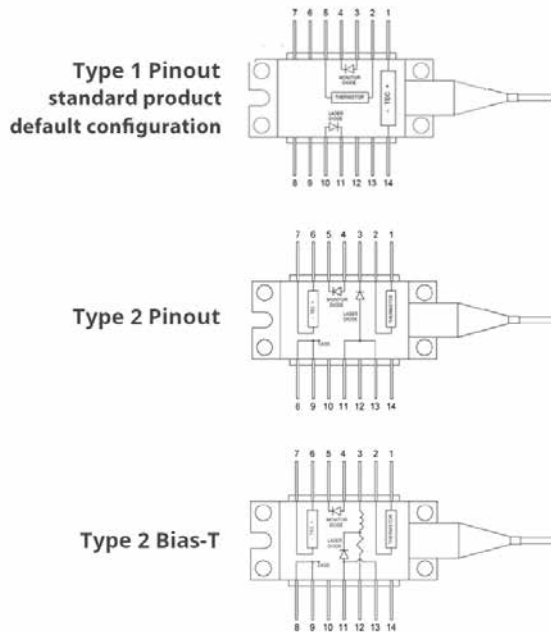

The standard model is for a type 1 pin configuration.

PRE-SET IMPEDANCE MATCHING IMPROVES THE LASER DIODE PULSE PERFORMANCE

When the impedance from the pulsed current source PCB is not properly matched to the butterfly package pins, significant pulse degradation can occur. This is often seen as distortion of the laser output pulses and/or overshoot of the pulses. Current sources inherently have a high output impedance and laser diodes have very low impedance. The most important requirement of proper impedance matching is matching the impedance of the load to the impedance of the transmission line. The inductance of laser diodes ranges from a few nanohenries to tens of nanohenries. From inductance theory, di/dt is the rate of change in current over

a specific period in amperes per second. The voltage increases with the inductance and with the rate of the change of the current. Energy stored in the inductor's magnetic fields during the pulse has to be released when the pulse ends. This creates a voltage, which in turn creates a new current, which in turn creates a new magnetic field on the transmission path. This creates a "loop" which manifests as "ringing" on the pulse waveform and on other distortions to the pulse shape. The CCS unit is designed to reduce and/or eliminate this pulse degradation by matching the nominal impedance of the butterfly packaged laser diode with the pulse transmission line.

GRAPHICAL USER INTERFACE INCLUDED

Configuration and operation of the controller is streamlined and simplified by providing control over the critical operating parameters of the controller: peak pulse current, pulse width, frequency, triggering, and other driver parameters are available.

The GUI also provides control over laser diode temperature, and includes operational safety limits to help protect the laser diode from damage.

In addition to providing real-time control over the laser diode, the GUI displays real-time operating status of the controller and laser diode operating parameters.

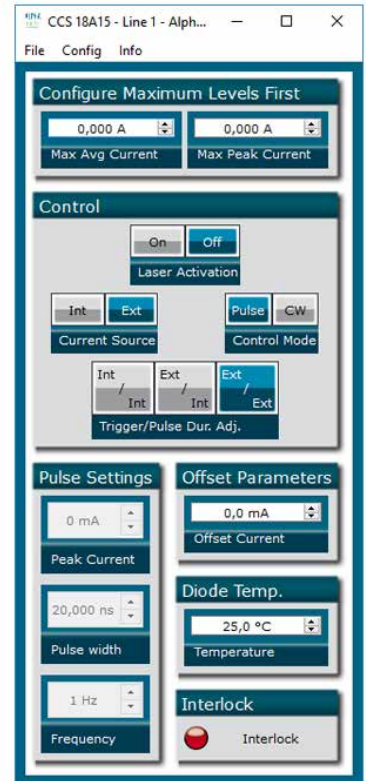



CCS-HP / Control and Mount Module Performance Specifications

Pulsed Output Electrical Specifications	<p>Output Current Range: 0 Amps ~ 3.5 Amps Adjustable Pulse Width Range; Internal Trigger: 0.5 nsec - 500 nsec Adjustable Pulse Width Range; External Trigger: 0.5 nsec - CW Internal Pulse Generator Adjustment Precision: 10 psec Internal Pulse Generator Repetition Rate Range: 1 Hz to 10 MHz Output Current CW (continuous) Mode: 0 Amps ~ 800 mA Output Voltage Maximum: 4.8 Volts Noise and Ripple (rms 100Hz to 10 MHz): < 0.03% Set-point Resolution @ 500 mA: 0.1mA Set-point Resolution @ 1000 mA: 0.3mA Back-Facet Power Monitor Connector</p>
Temperature Controller, Butterfly Mounting Socket	<p>TEC Current (max): 1.5 Amps TEC Voltage (max): 3.8 Volts Zero Insertion Force Mounting Socket for 14-Pin Butterfly TEC Controller Compatible with NTC Thermistors: 1 kΩ - 100 kΩ</p>
Laser Diode Protection	<p>User set Over-Current limit shut down Over-Temperature limit shut down Safety interlock shut down Soft-Start ramp to current set-point (CW mode) Transient and ESD surge protection Fast error detection and shut down feedback</p>
User Interface, Power Input, Dimensions	<p>Remote: USB with Control Software GUI DLL Library for C programming and Hexadecimal Protocol are available at no charge Analog (0-3.3V) Remote Signal Peak Power Adjustment Input Power Supply: 12 VDC (220V/110V adapter included) Input Power Supply: 12 VDC (220V/110V adapter included) 146 mm (W) x 130 mm (L) x 37 mm(H)</p>
Pulse Generation Mechanisms (3 Modes)	<p>Internal Pulse Generator: On-board pulse generator External Trigger to Internal Pulse Generator: User supplied LVTTTL signal triggers (on the rising edge) the internal generator to deliver the pulse. The pulse parameters are set in the internal pulse generator and the pulse is delivered from the internal generator. External Trigger Pulse Generator: Pulse duration is the same as the external trigger pulse duration</p>
Pin Configuration Model Selection	<p>Type 1: (Standard, Type 1 pin configuration) Type 2: (Optional Type 2 pin configuration) Type 2 Bias-T: (Optional Type 2 with internal bias-t pin configuration)</p>



Offered by
LASER LAB SOURCE



LASER
DIODE
CONTROLLERS



PRODUCT SALES AND SERVICE

Unlimited phone and email support is provided for products purchased through Laser Lab Source. Orders for this product are fulfilled by Laser Lab Source in North America and select international regions. It is manufactured by AeroDIODE, Talence, France.

PRODUCT WARRANTY

This product is sold with a full one-year warranty. It is warranted to be free from defects in material and/or workmanship for a period of one year from the date of shipment. The warranty does not cover damage to the to the product due to mishandling or use of the product outside of its specified maximum ratings.



Laser Lab Source, Inc
1820 W. Lincoln Street
Bozeman, MT 59715
contact@LaserDiodeSource.com
800-877-5065

AeroDIODE

Rue François Mitterrand Institut d'Optique d'Aquitaine
33400 Talence
FRANCE