

AEO LDC-003 Diode Laser Controller Module

1.1 Production General Description



The AEO LDC-003 diode laser controller module provides a low noise universal diode laser power supply driver with constant current and temperature control. It provides users an easy and economical solution for setup a laser source, and at the same time, keep the similar high performance of expensive instrument type laser light source.

1.2 Built-In Laser Diode Protection Features

Built in internal laser current drive current slow start, over current limit, fast over current surge protection method, relay short the laser in power off status.

Key performance Features

- Low Noise and Highly Stable constant current up to 3A
- Analog modulation signal frequency is up to 100 khz.
- Multiple Built-In Laser Diode Protection Features
- Temperature set range up to 10 °C~35°C
- Excellent Temperature Stability < 0.005 °C)
- Excellent current stability ± 0.0 1%.
- Widely input DC power supply range, excellent benefit for battery power supply instrument.
- Easy control output current and temperature via UART port.
- Fast laser light emission turns on/ off through external TTL voltage trigger, meanwhile keeping internal temperature control, maximum laser protection.
- Laser light emission turns on/ off either uses external TTL voltage trigger or Uart serial port.
- Linear slow start current ramp to set point
- Reverse voltage transient clamp
- Relay short circuit when laser diode current turned OFF



1.3 Front Panel Function and Overview

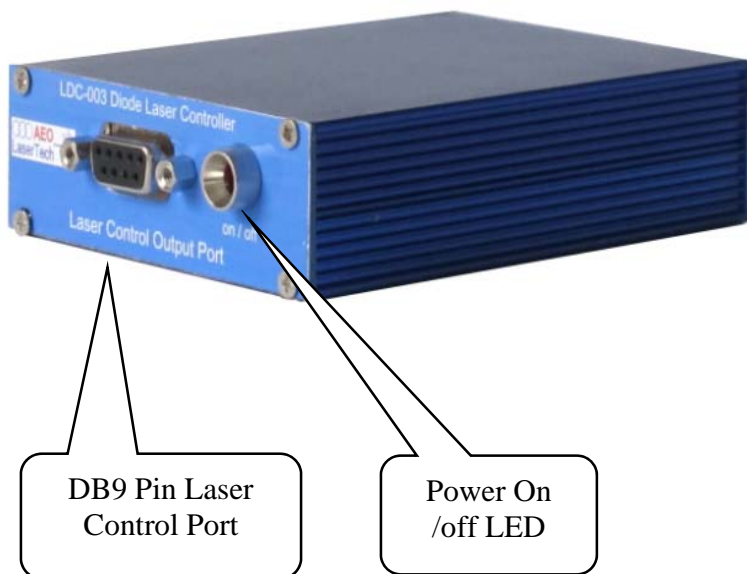

1.4 Laser Diode Current Controller Connection Cable diagram

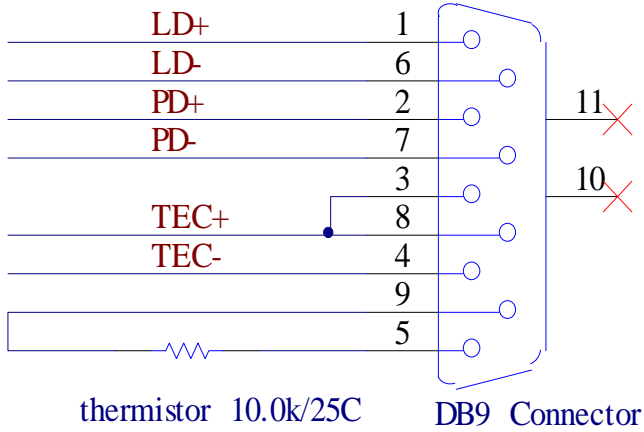

Front Panel Laser control port wire connection

Laser Control Port Pin Definition	
Pin #	Description
1	Laser positive (+)
6	Laser negative (-)
2	Photo detector positive (+)
7	Photo detector negative (-)
3, 8	TEC positive (+)
4	TEC negative (-)
9	thermistor
5	thermistor

Front Panel Pin function definition Table

1.5 Rear Panel Function and Overview

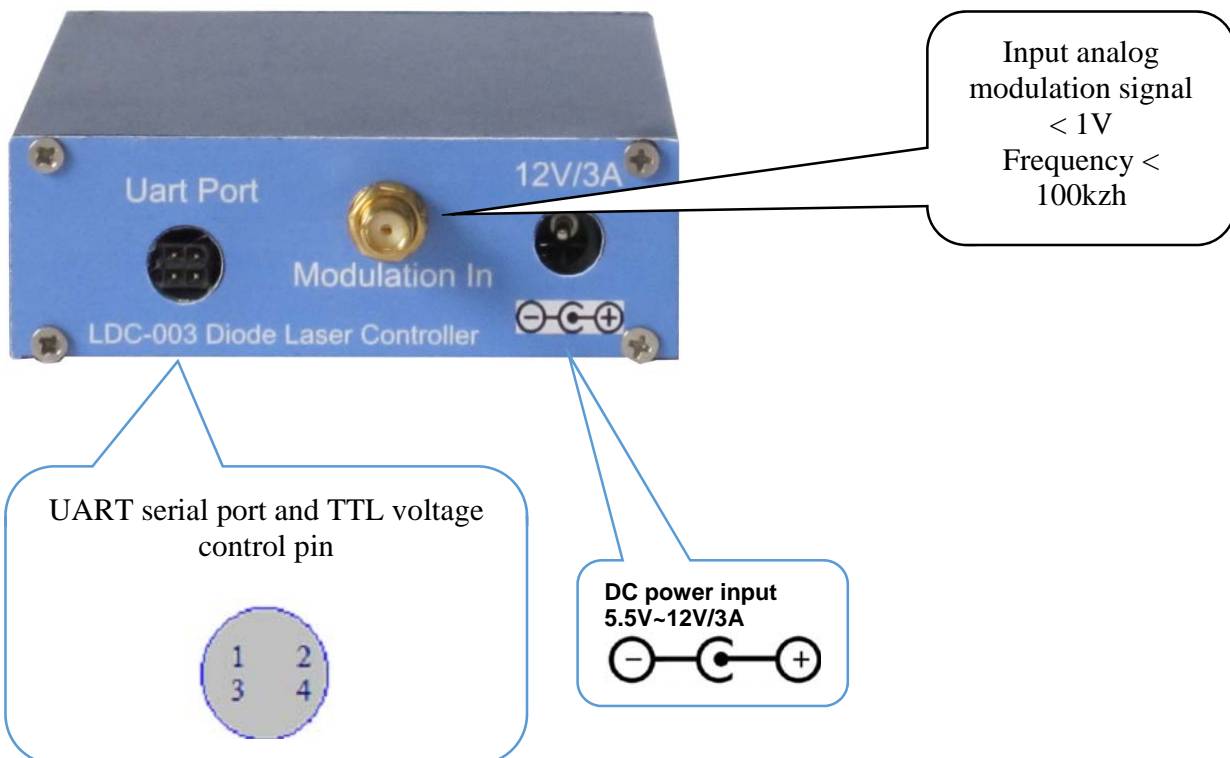

Pin #	Description	Voltage	Input / Output	Function
1	UART Rx	0~5V	Input	Receive signal
2	UART Tx	0~5V	Output	Transmit signal
3	External rising and falling trigger	0~5V	Input	VL = Laser Turn off
		0~5V		VH = Laser Turn on
4	GND	0V		GND

Rear Panel Pin function definition Table

2. AEO Laser Controller User Interface Software

Users can either use free user interface software or communication code to control lasers.

2.1 Port set: Serial communication set in 115200 baud rate, 8 data bits, 1 stop bit, no parity, and no handshake.

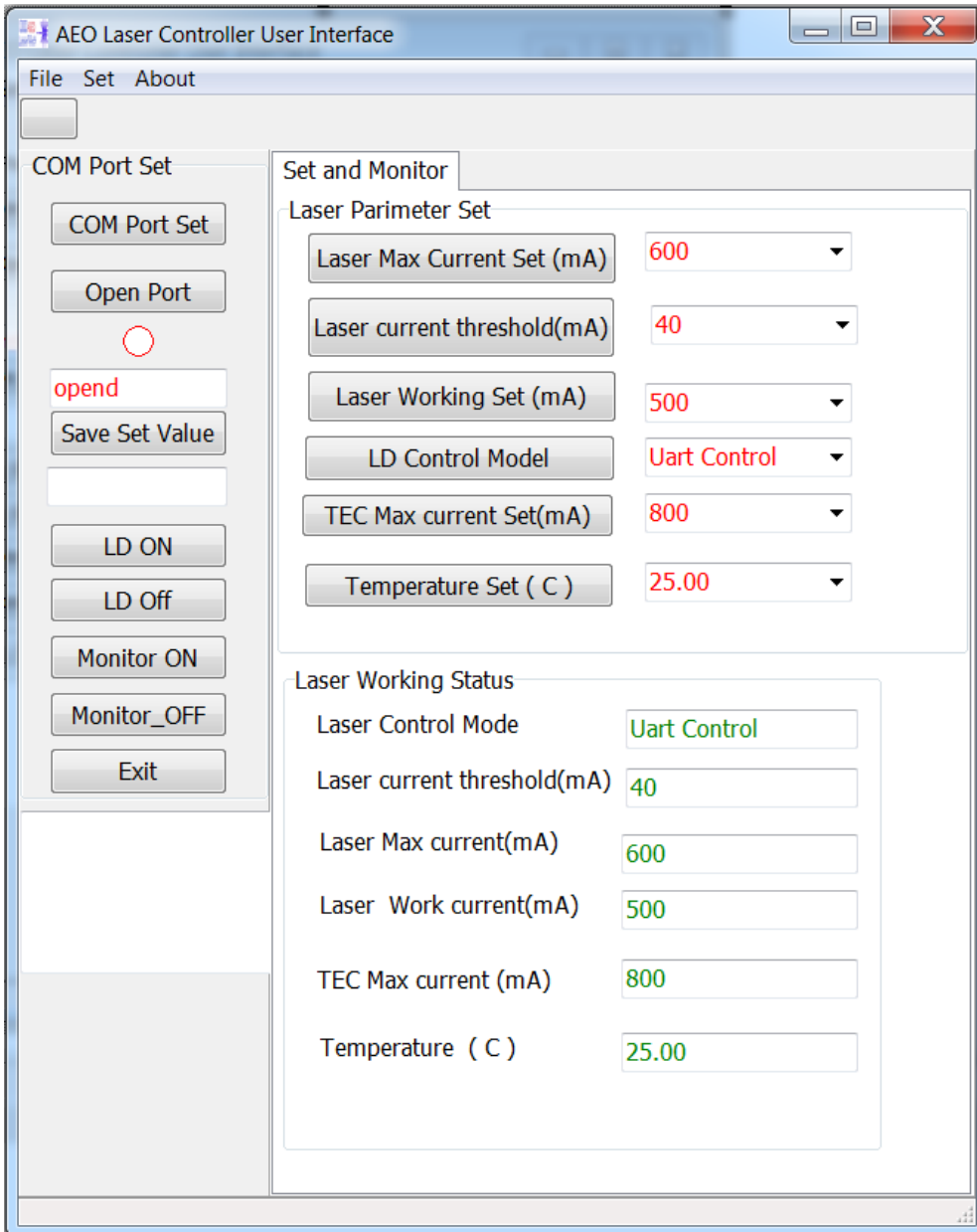

3. Control Communication Protocol:

3.1 Serial Port Setting

Serial communication with 115200 baud rate, 8 data bits, 1 stop bit, no parity, no handshake

3.2 Command Structure

3.2.1 Command Definition:

Control Communication Protocol

Command Syntax	<p><Command><=><VALUE><&></p> <p><Command> are ten ASCII character.</p> <p><=> is a separator to separate variable and value.</p> <p><VALUE> is several decimal numbers in ASCII.</p> <p>There are no space in the Data (Stream).</p> <p><&> is a separator, which indicate the end of one data structure.</p>
Serial Port Setting	115200 Baud rate, 8 data bits, 1 stop bit, no parity, no handshake

Command Summary

Command	Command Syntax	Function	Note
LdMode_Set	LdMode_Set=1&	Serial Port Control	
	LdMode_Set=0&	External Trigger Control on/off	
LD_Turn_ON	LD_Turn_ON=1&	Laser emission Turn On	
	LD_Turn_ON=0&	Laser emission Turn Off	
LdMax_ISet	LdMax_ISet=xxxx&	laser maximum current setting(mA)	
	Ex: LdMax_ISet=1000&	Ex: laser maximum working current = 1000mA	
LdWk_I_Set	LdWk_I_Set=xxx&	laser working current setting(mA)	< Internal default maximum limit
	Ex: LdWk_I_Set=300&	laser working current = 300mA	
TcWk_C_Max	TcWk_C_Max=xxxx&	TEC maximum working current (mA)	< Internal default maximum limit
	TcWk_C_Max=1000&	TEC maximum working current = 1000(mA)	
TcWk_T_Set	TcWk_T_Set=xxxx&	TEC temperature set	< among default maximum range
	Ex: TcWk_T_Set=2500&	Ex: TEC temperature set : 25.00 °C	

3.3 TEC control note:

External thermistor is a NTC type.

Thermistor value = 10.00 kohm @25.00°C

4. Safety Requirement

4.1 User Responsibility

The AEO-LDC-3 series laser controller provides laser driving current up to 3A, which can emit to more than Class 3 laser products. Extreme care should be taken, when operating this device to avoid potentially hazardous exposure to both eyes and skin. Users should wear eye protection when operating this device to driving lasers and should avoid exposure to the output beam of lasers.



LASER RADIATION
AVOID EXPOSURE TO THE BEAM
CLASS 3 LASER PRODUCT >300 mW



5. Warranty:

AEO Lasertech guarantees its products to be free of defects for one year from the date of shipment. During the warranty period, AEO Lasertech will, at its option, either repair or replace products, which prove to be defective. Opening, modification will cause warranty void. This is in lieu of all other guarantees, expressed or implied, and does not cover incidental or consequential loss.