



*This product is sold
and supported
in the USA by*



LASER LAB SOURCE
marketplace for **Scientists & Engineers**

contact@LaserLabSource.com

800.887.5065

DATASHEET AND OPERATING GUIDE

LDMOUNT-5A

5A Butterfly 14-Pin Laser Diode Mount



laser diode not included

FEATURES AND BENEFITS

- Capable of running lasers up to 5 A
- Capable of running thermoelectrics up to 5 A
- Compatible with 14-pin butterfly laser diode packages
- Type 1 & Type 2 butterfly packages are supported with pre-soldered connection card
- Other laser types supported with customer soldered Custom Butterfly Card
- Zero insertion force (ZIF) socket holds laser diode
- Laser interlock safety circuit
- TEC Active/Bypass interlock safety circuit
- Mounts to an optics table with standard 1/4-20" screw
- Compatible with 8 Wavelength temperature controllers and laser drivers

VERSATILITY

Designed for 14-pin butterfly laser diodes with internal thermistors and Thermo Electric Coolers (TEC), the **LDMOUNT** is a laser diode mount with integrated heat sinking, and simple connections between the drivers and the diode laser.

The LDMOUNT has easy connectivity. A zero insertion force (ZIF) socket holds the laser. Two 9-pin DSUB connectors enable TEC and laser driver control.

Two basic butterfly laser diode types are supported. For any other pinout, the LDMOUNT-CU Card is available for hand wiring.

SAFETY

The LDMOUNT has several built-in safety features. These include a reverse bias protection diode across the laser diode, an interlock circuit for the laser diode current, and a TEC Active/Bypass switch to require active temperature control before laser current can be enabled.

APPLICATIONS

The LDMOUNT is ideal for pump and communication diode lasers. The user is able to change between the types easily by using the provided pre-configured connection card.

ORDERING INFORMATION

PART NO.	DESCRIPTION
LDMOUNT-5A	5 A Laser Diode Mount, Type 1 & Type 2
WCB323	Interlock Cable (included)
LDMOUNT-CU	Custom Butterfly Card
WCB319	TC LAB Connector Cable
WCB316	LFI3751 Connector Cable
WCB317	WTC Connector Cable
WCB318	WLD Connector Cable
WCB320	LDTC Series Connector Cable
WCB321	PLD-5K Connector Cable
WCB322	PTC-5K Connector Cable
THERM-PST	Thermal Paste

CONTENTS

	PAGE
CONNECTION GUIDE	2
PIN CONNECTIONS - TYPE 1	8
PIN CONNECTIONS - TYPE 2	9
PIN CONNECTIONS - DSUB	10
ELECTRICAL SPECIFICATIONS	11
ADDITIONAL TECH NOTES	12
TROUBLESHOOTING	14
CABLE SPECIFICATIONS	15
MECHANICAL SPECIFICATIONS	18
CERTIFICATION AND WARRANTY	19

406-587-4910

www.teamWavelength.com

Applies to Product Revision A
© June 2017



WAVELENGTH
ELECTRONICS

CONNECTION GUIDE

MAXIMUM OPERATING TEMPERATURE



The LDMOUNT is designed to operate at temperatures below 50°C for customer, laser, and LDMOUNT safety. Operating at temperatures greater than 50°C may damage components, or the LDMOUNT.

Review the both the laser diode and the temperature controller datasheets and their online SOA calculators for driver operation restrictions.

Laser diode drivers SOA calculator can be found [here](#).
 Temperature controller SOA calculator can be found [here](#).

ELECTROSTATIC DISCHARGE PRECAUTIONS

Prior to operation of the LDMOUNT, it is imperative that measures are taken to prevent damage from electrostatic discharge (ESD). ESD can damage the laser, the drivers, or other components. Simple precautions can prevent ESD damage.

Wavelength recommends that ESD precautions are always observed when handling the LDMOUNT and other components.

CHOOSE LASER TYPE

The first step to connect the LDMOUNT is to decide which type of diode laser is being used. The two standard types are shown in the figures below. See **Additional Tech Notes** for more packages that are supported by the LDMOUNT.

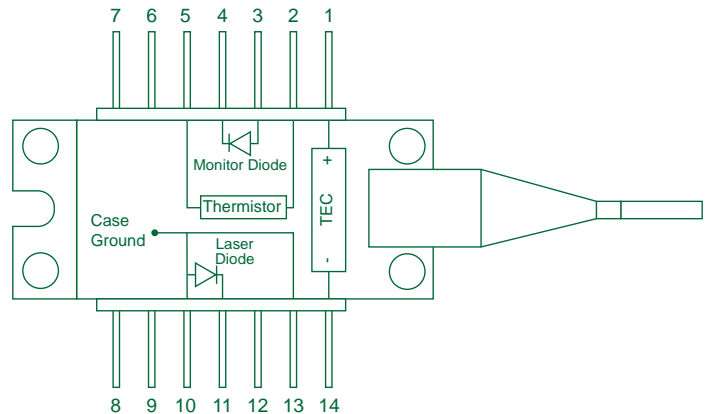

Figure 1. Standard Type 1 Laser Diode schematic.

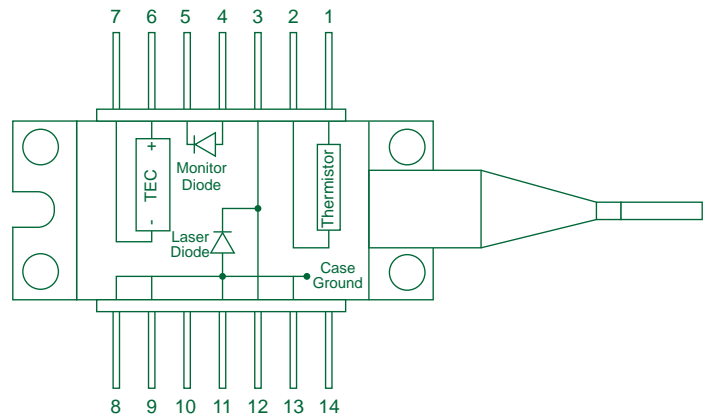

Figure 2. Standard Type 2 Laser Diode schematic.

If the laser chosen does not fall into one of these two categories, a Custom Butterfly Card is available, which allows the user to configure the connections between the butterfly package and the LDMOUNT to their specific needs. More information about the Custom Butterfly Card can be found in the **Additional Tech Notes** Section.

INSTALL CONNECTION CARD OR CUSTOM BUTTERFLY CARD

Once the type of laser has been chosen, remove the access cover on the bottom of the LDMOUNT and install the connection card (or configured Custom Butterfly Card).

To install, line up the 24 pin female connector with the 24 pin male pins on the LDMOUNT, and push the card onto the pins until it is firmly seated.



Figure 3. Main board with no connection card.



Figure 6. Align the connection card with the 24 pins.

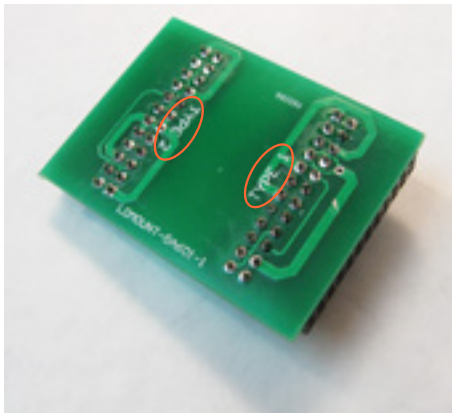

Figure 4. Pre-configured connection card. Allows operation of either a Type 1 or Type 2 laser.

When the connection card is properly installed, either “TYPE 1” or “TYPE 2” will be visible through the viewing window of the access cover on the bottom of the LDMOUNT.



Figure 7. Fully seated, properly installed connection card for a Type 1 laser.

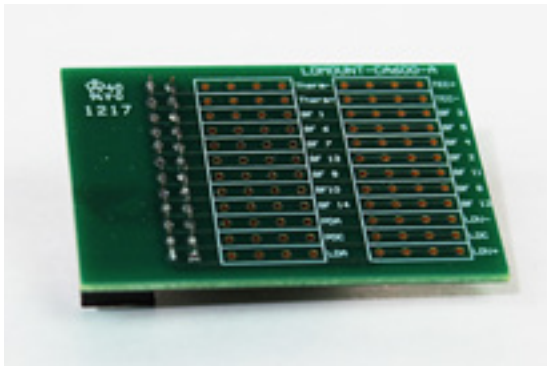

Figure 5. Custom Butterfly card. Allows operation of any 14-pin electro-optic device.

The connections from the DSUBs (TEC and laser drivers) to the 14-pin butterfly mount are shown in **Figure 18** and **Figure 19**. Note that these are not direct connections, they first go to the connection card (or Custom Butterfly Card), then to the butterfly mount. Thus, it is imperative that the connection card (or the Custom Butterfly Card) is installed properly before use of the LDMOUNT.

JUMPERS

The LDMOUNT has four configurable jumpers (labeled JP on the board, see **Figure 8**). Three of the four are configured using shorting jumpers, while one requires soldering.

JP1 - MODULATION INPUT

JP1 connects a separate modulation input from the laser diode driver for Type 2 diode lasers. If no extra modulation input is desired, leave JP1 unconnected. JP1 requires soldering. It is found on the main board where pin 12 of the butterfly package connects. The main board is shipped with JP1 not soldered.

JP2 - LD ANODE TO LD DSUB CASE & CABLE SHIELD

JP2 ties the LD DSUB case to the LD Anode and case ground. JP2 is connected by a shorting jumper. If a Type 1 or Type 2 laser with a grounded LD Anode is used, it is recommended that JP2 is left uninstalled to avoid creating a ground loop.

JP3 - THERMISTOR TO LD ANODE

JP3 is connected by a shorting jumper. Connecting JP3 connects the Thermistor to the LD Anode.

JP4 - LD ANODE TO PD CATHODE

JP4 connects the LD Anode to the PD Cathode. If the PD and LD are electrically isolated, install JP4. Then, operate the Wavelength laser diode driver for a Type A laser. If using a non-Wavelength laser diode driver, this jumper may or may not be required. JP4 is connected by a shorting jumper.

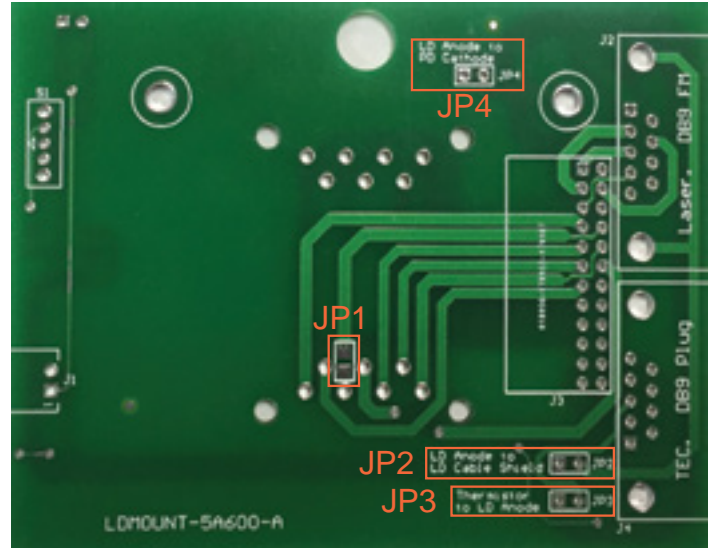

Figure 8. Image of the main board, showing the jumpers.

JUMPER	CONNECTION 1	CONNECTION 2	FACTORY DEFAULT	ATTACHMENT
JP1	External Modulation	Butterfly Pin 12	Uninstalled	Solder
JP2	Laser Diode Anode	Laser Diode DSUB Case & Cable Shield	Uninstalled	Shorting Jumper
JP3	Thermistor	Laser Diode Anode	Uninstalled	Shorting Jumper
JP4	Laser Diode Anode	Photodiode Cathode	Installed	Shorting Jumper

Table 1. Summary of connections made by jumpers and factory default installation.

INTERLOCK & BYPASS

The LDMOUNT has a built-in interlock circuit and a TEC Bypass switch (both located on the side opposite the 9-pin DSUB connectors).



Figure 9. Interlock & Bypass side of the LDMOUNT. Interlock connection is on the left. Bypass switch is on the right.

In order for the LDMOUNT to operate a laser, both the Interlock and Bypass Loops must be properly configured.

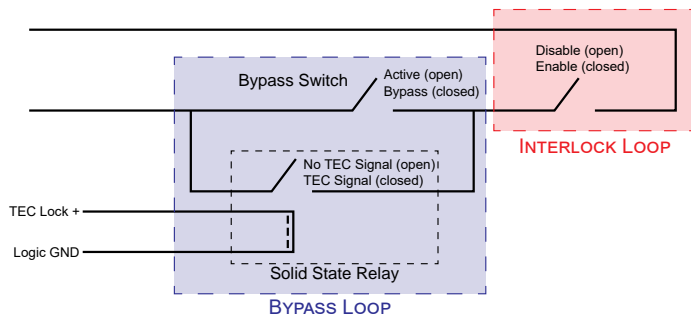

Figure 10. Safety Interlock overview. In this case, no current will flow to the laser, as the loops are not completed.

The interlock can be completely bypassed by shorting pins 1 and 5 of the LD DSUB or by installing the interlock cable provided and setting the TEC switch to Bypass.

If the interlock is bypassed by shorting pins 1 and 5 at the LD DSUB, the LDMOUNT cannot stop current flowing to the laser, regardless of whether the TEC switch is set to Active or Bypass.

The rest of this section assumes that pins 1 and 5 of the LD DSUB are not shorted.

UTILIZING THE INTERLOCK CABLE

The unit ships with an interlock cable (WCB323) that can be plugged in if an active interlock circuit is not desired. In order to connect an active interlock, cut the loop on the Interlock cable, connect the active interlock circuit to the two wire leads, and then plug the interlock cable into the LDMOUNT. A Molex 2 pin housing (50-57-9402-P) is the plug used for the interlock cable.

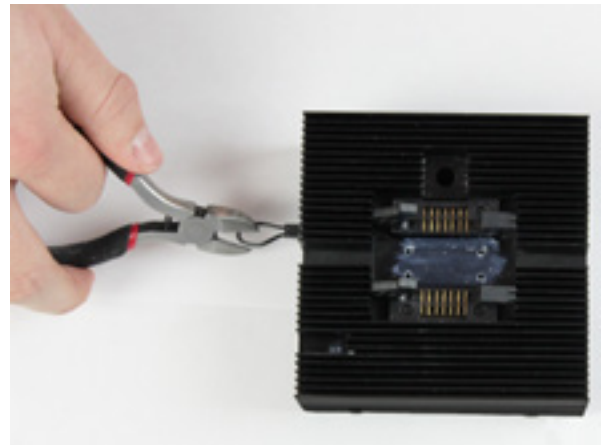

Figure 11. Interlock cable installed. If an active interlock circuit is desired, snip the wire and connect the circuit.

COMPLETING THE INTERLOCK LOOP

The Interlock Loop must be completed by making a short circuit between the pins of the Interlock connector.

UTILIZING THE TEC BYPASS SWITCH

The TEC Bypass switch has two options, *Bypass* and *Active*.

If the switch is set to *Bypass*, the LDMOUNT will not look for a disable signal from a temperature controller, and will allow the laser driver to supply current to the diode laser.

When the switch is set to *Active*, the LDMOUNT can open the laser diode driver interlock circuit and disable current to the diode laser if there is a disable signal from a temperature controller. There must be a LOGIC HI signal across pins 1 and 9 (TEC LOCK+ and TEC LOCK-) of the TEC DSUB that can source at least 1.1mA in order for the LDMOUNT to allow operation of a laser when in *Active* mode.

COMPLETING THE BYPASS LOOP

The Bypass Loop can be completed in either *Bypass* or *Active* mode.

When the switch is set to *Bypass*, the Bypass Switch is closed, and the Bypass Loop is completed (see **Figure 12**).

When the switch is set to *Active*, the Bypass Switch is open (as shown in **Figure 13**). In this case, the Solid State Relay will only conduct and close the switch when there is a signal from the TEC.

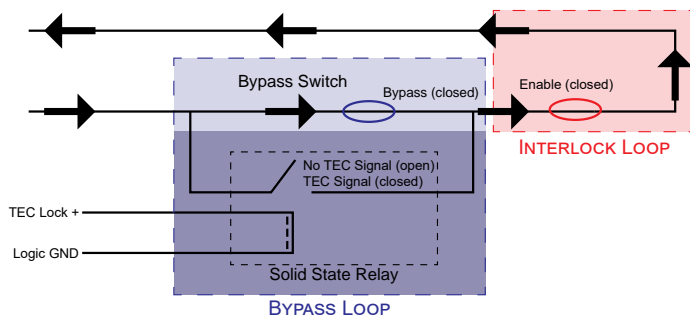

Figure 12. Correctly set up circuit for bypassing the TEC signal.

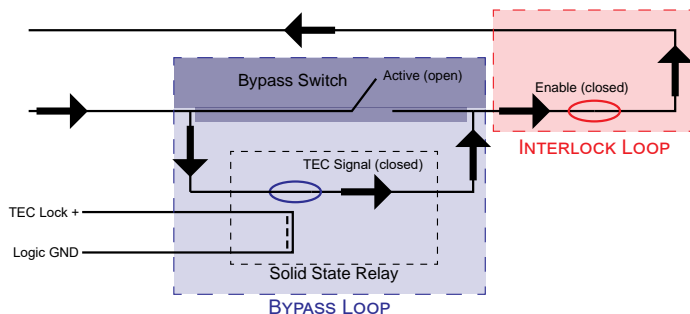

Figure 13. Correctly set up circuit for an active signal from the TEC.

MOUNTING THE DIODE LASER

After the type of diode laser has been chosen, the connection card has been installed properly, the jumpers have been configured, the Interlock circuit has been set up properly, and the access cover replaced, the chosen type of diode laser can be placed into the ZIF clamps, and operated.

To mount the diode laser onto the LDMOUNT, unclamp the ZIF clamps by pushing down on the smaller, top clamp and open the clamps all the way.



Figure 14. Open the ZIF sockets by pushing on the smaller top clamp, as shown.

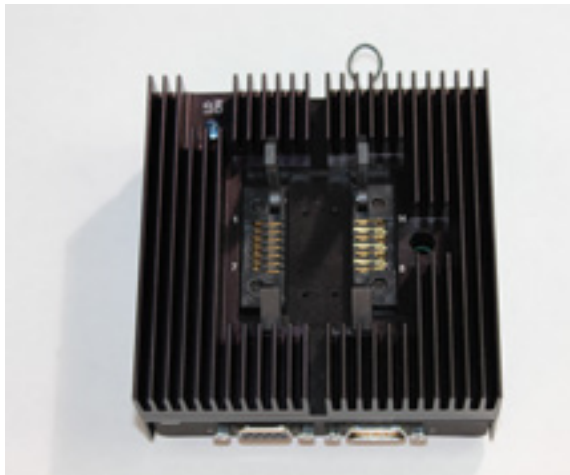

Figure 15. Open the ZIF socket all the way to gain access to the pins.

Once the ZIF socket is open, seat the diode laser such that the 14-pin butterfly pins are in physical contact with their corresponding ZIF socket pins. For increased thermal conductivity, put a layer of thermal paste on the bottom of the butterfly package prior to seating on the LDMOUNT.



Figure 16. Seat the laser such that the butterfly pins from the butterfly package make physical contact with their corresponding ZIF pins.

Next, mount the diode laser by screwing the four mounting screws onto the LDMOUNT using the through holes on the butterfly package. Finally, close and secure the ZIF clamps.

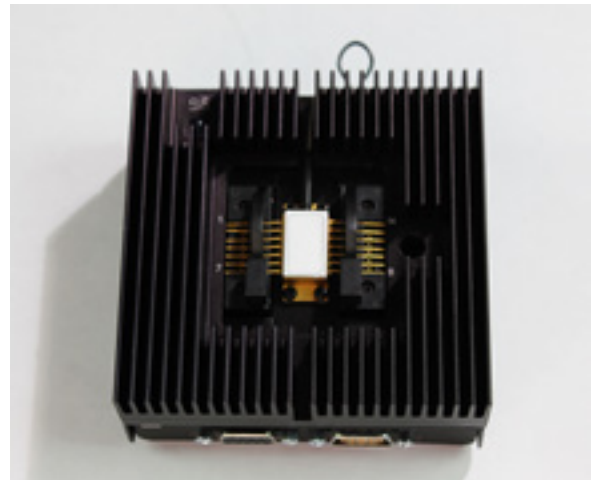

Figure 17. Fully seated butterfly package. Four mounting screws placed, and ZIF sockets closed and secured.

DSUB TO 14-PIN BUTTERFLY CONNECTIONS

The connections from the 9-pin DSUB ports, TEC and laser diode driver (LDD) to the 14-pin butterfly laser in the ZIF are shown in **Figure 18** and **Figure 19**. They are further discussed in the next three sections.

PIN CONNECTIONS - TYPE I

BUTTERFLY PIN NUMBER	SYMBOL	NAME	DSUB PIN	
			TEC	LDD
1	TEC+	Thermoelectric (+)	4	
2	Therm+	Thermistor (+)	2	
3	PD An	Photodiode Anode		4
4	PD Cath	Photodiode Cathode		2
5	Therm-	Thermistor (-)	3	
6	—	No Connection		
7	—	No Connection		
8	—	No Connection		
9	—	No Connection		
10	LD An	Laser Anode		3
11	LD Cath	Laser Cathode		7
12	—	No Connection		
13	Case Gnd	Case ground		3
14	TEC-	Thermoelectric (-)	5	

Table 2. Internal Pin Connections for Type 1 Butterfly Laser Diode

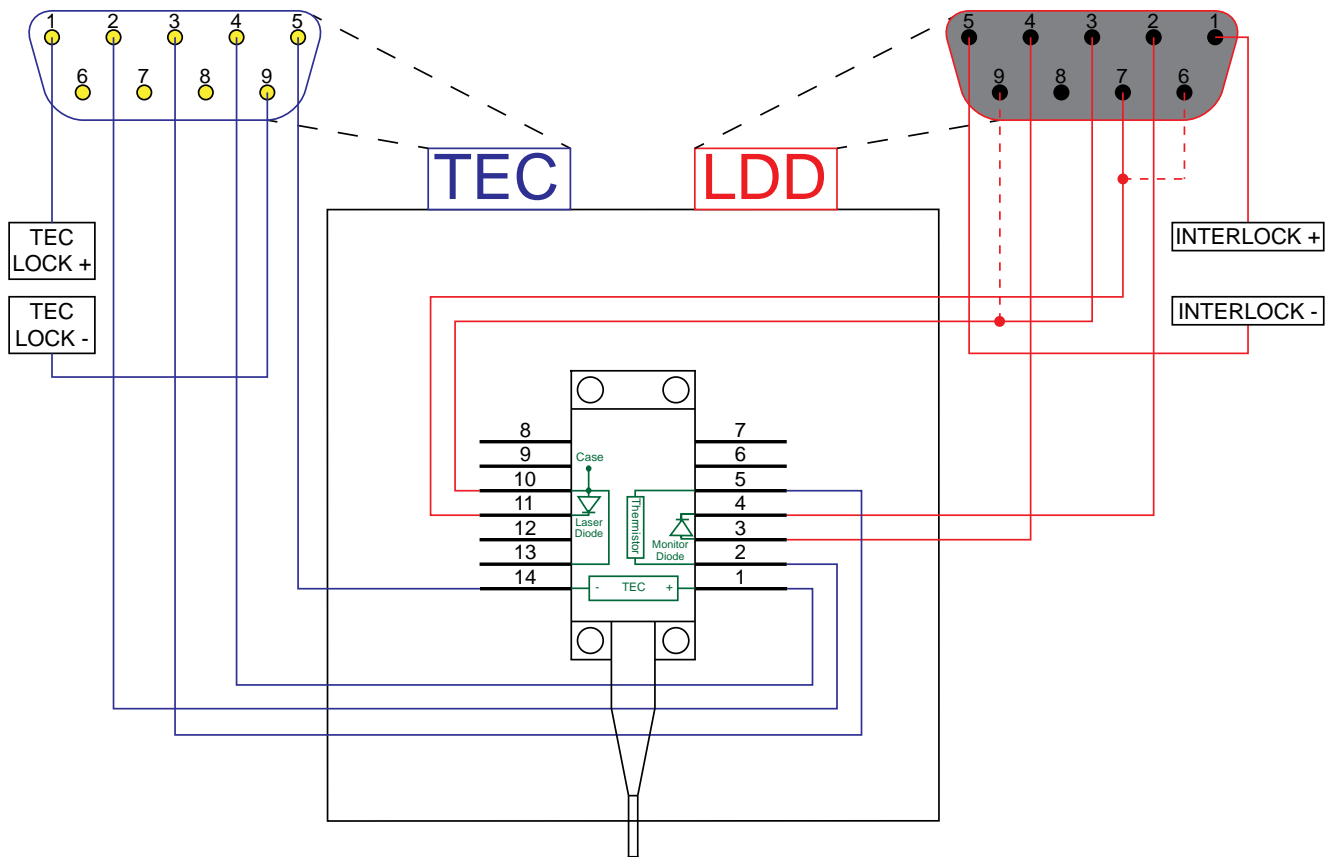

Figure 18. Wiring Diagram for Type 1 Butterfly Laser Diode

PIN CONNECTIONS - TYPE 2

BUTTERFLY PIN NUMBER	SYMBOL	NAME	DSUB PIN	
			TEC	LDD
1	Therm+	Thermistor (+)	3	
2	Therm-	Thermistor (-)	2	
3	LD Cath	Laser Diode Cathode		7
4	PD An	Photodiode Anode		4
5	PD Cath	Photodiode Cathode		2
6	TEC+	Thermoelectric (+)	4	
7	TEC-	Thermoelectric (-)	5	
8	Case Gnd	Case ground		3
9	Case Gnd	Case ground		3
10	—	No connection		
11	LD An / Case	Laser Diode Anode / Case ground		3
12	Mod	Modulation*		7
13	LD An / Case	Laser Diode Anode / Case ground		3
14	—	No connection		

* This is a parallel input to the laser diode cathode

Table 3. Internal Pin Connections for Type 2 Butterfly Laser Diode

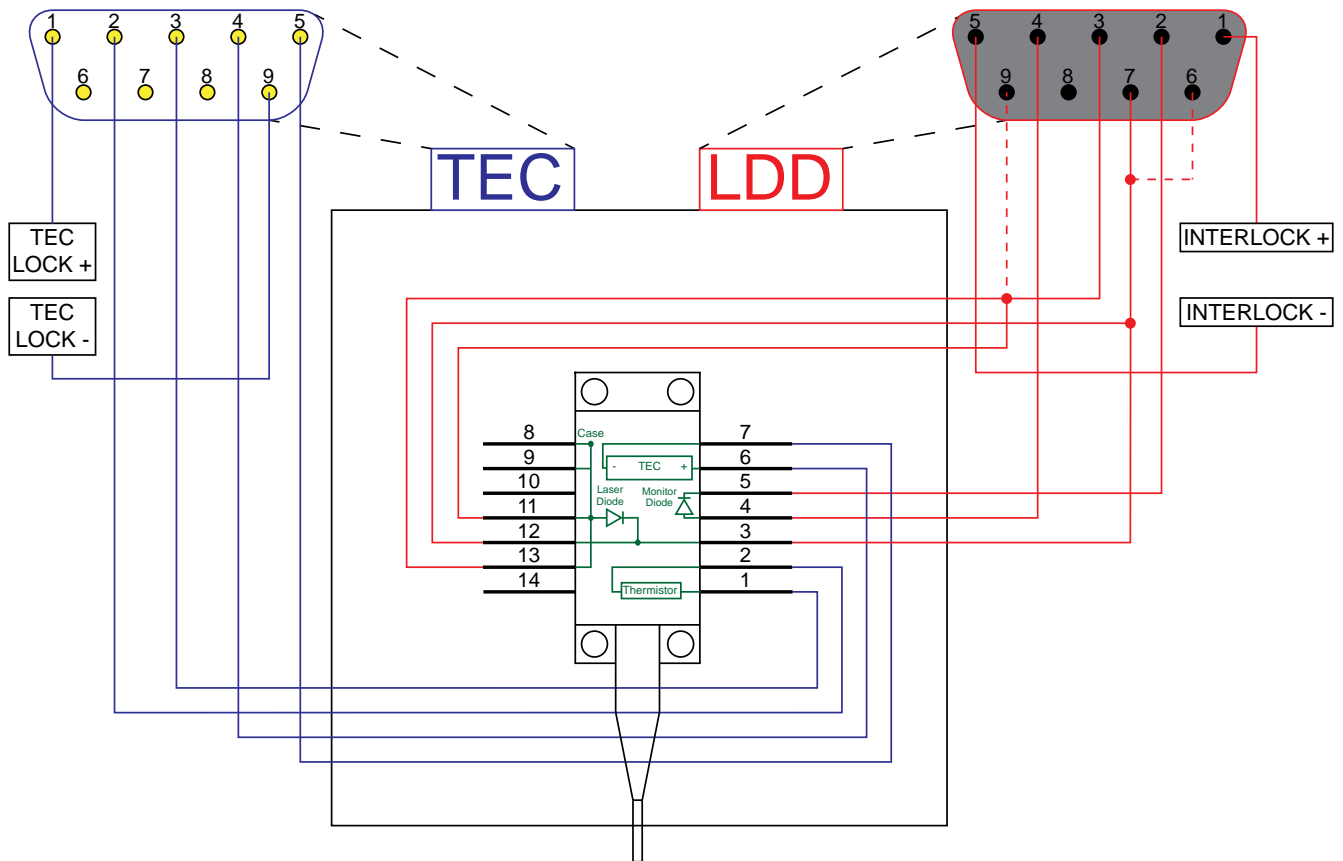

Figure 19. Wiring Diagram for Type 2 Butterfly Laser Diode

PIN CONNECTIONS - DSUB

TEC 9-PIN DSUB CONNECTIONS

TEC DSUB PIN NUMBER	CONNECTS TO	ADDITIONAL NOTES
1	TEC LOCK+	There must be at least 1.1mA of current between pins 1 and 9 of the TEC DSUB in order to have an “active” signal from the TEC to the LDMOUNT.
2	Thermistor-	Makes a connection to the internal thermistor in the diode laser.
3	Thermistor+	Makes a connection to the internal thermistor in the diode laser.
4	Thermoelectric+	Connects to the positive terminal of the TEC.
5	Thermoelectric-	Connects to the negative terminal of the TEC.
6	No Connection	—
7	No Connection	—
8	No Connection	—
9	TEC LOCK- / Logic GND	There must be at least 1.1mA of current between pins 1 and 9 of the TEC DSUB in order to have an “active” signal from the TEC to the LDMOUNT.

Table 4. Connections between the TEC DSUB and diode lasers.

LDD 9-PIN DSUB CONNECTIONS

LDD DSUB PIN NUMBER	CONNECTS TO	ADDITIONAL NOTES
1	INTERLOCK+	This pin enables interlock circuitry to be wired to the LDMOUNT.
2	Photodiode Cathode	Connects to the cathode of the monitor photodiode.
3	Laser Diode Anode	Makes a connection to the anode of the laser diode.
4	Photodiode Anode	Connects to the anode of the monitor photodiode.
5	INTERLOCK-	This pin enables interlock circuitry to be wired to the LDMOUNT.
6	Laser Diode Cathode Monitor	Used to monitor voltage across LD. There is a 470Ω resistor between this DSUB pin and the LDC.
7	Laser Diode Cathode	Makes a connection to the anode of the laser diode.
8	No Connection	—
9	Laser Diode Anode Monitor	Used to monitor voltage across LD. There is a 470Ω resistor between this DSUB pin and the LDA.

Table 5. Connections between the LDD DSUB and diode lasers.

ELECTRICAL SPECIFICATIONS

PARAMETERS	MIN	TYP	MAX	UNIT	NOTES
Laser Specifications					
Supported Lasers, 14-pin Butterfly	Type 1, Type 2, other				Use Custom Butterfly Card for other pinouts.
Max. Laser Current			5	Amps	5A limit on PCB pins.
Laser Polarity	Anode Grounded				
Thermoelectric Controller Specifications					
Max. TEC Current			5	Amps	5A limit on PCB pins.
Max. TEC Voltage	Laser specific				
TEC Heating/Cooling Capacity	Laser specific				
Temperature Range	Laser specific				
Temperature Sensors	Thermistor				
Interlock Input Specifications					
Type of Mating Connector	0.100			inches	2 Position Rectangular Housing (Molex 50-57-9402-P).
Open Circuit Voltage	Laser Diode Driver specific				
Short Circuit Current		10		mADC	
Connector Polarity	Pin 2 is positive				
External Interlock Switch Requirements	Must be normally open dry contacts.				No external voltages applied to the Interlock input.
Bypass Switch Specifications					
Logic Level Source Current	1.1			mA	Between pins 1 and 9 from the TEC DSUB.



DO NOT EXCEED 50°C OPERATING TEMPERATURE FOR SAFETY.



ADDITIONAL TECH NOTES

OTHER TYPE 1 LASERS SUPPORTED

In addition to the standard Type 1 laser, the LDMOUNT is capable of handling Type 1 lasers which have the photodiode connection between pins 7 and 8 on the butterfly package, and the laser diode connection between pins 9 and 10 on the butterfly package. See **Figure 20** below for a schematic of this type of laser.

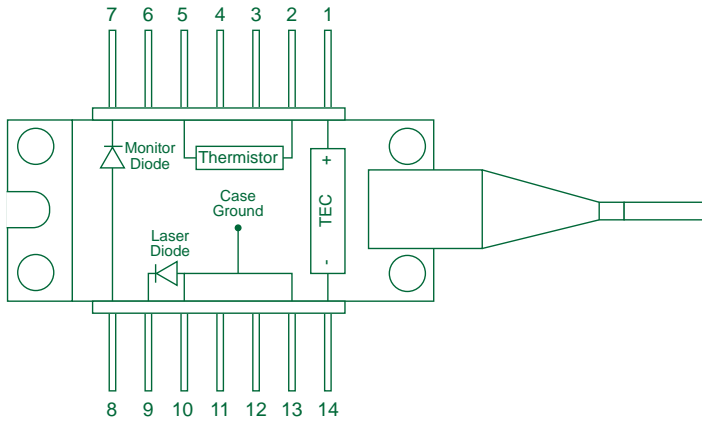

Figure 20. Alternate Type 1 laser configuration supported by the LDMOUNT.

If this type of laser is used in the LDMOUNT, no additional wiring or configuration is required. The connection card is pre-configured for this type of laser as well. Mount the connection card such that “Type 1” is visible through the viewing window, and proceed with setup as described in the **Connection Guide**.

BUTTERFLY PIN NUMBER	SYMBOL	NAME	DSUB	
			TEC	LDD
1	TEC+	Thermoelectric (+)	4	
2	Therm+	Thermistor (+)	2	
3	—	No Connection		
4	—	No Connection		
5	Therm-	Thermistor (-)	3	
6	—	No Connection		
7	PD Cath	Photodiode Cathode		2
8	PD An	Photodiode Anode		4
9	LD Cath	Laser Cathode		7
10	LD An	Laser Anode		3
11	—	No Connection		
12	—	No Connection		
13	Case Gnd	Case ground		3
14	TEC-	Thermoelectric (-)	5	

Table 6. Internal Pin Connections for alternate Type 1 Butterfly Laser Diode

CURRENT SOURCE

The LDMOUNT is designed for use with laser diodes that have the laser diode anode (LDA) grounded. As such, the laser diode cathode (LDC) is at a negative potential. If the LDMOUNT is driven with a positive current to the LDC, the diode clamp between the LDA and the LDC connections at the 9-pin DSUB will conduct. This will short the LD pins. Thus, no current will be driven to the laser.

If the Custom Butterfly Card is wired for an alternate configuration, it must be ensured that current is flowing correctly between the LDA and the LDC as described above.

CUSTOM BUTTERFLY CARD

The Custom Butterfly Card can be used to allow different butterfly packages (other than the Type 1 or Type 2 lasers shown) to be mounted in and used with the LDMOUNT. It comes raw (no pre-configured connections), and requires soldering by the user to make the desired connections. Additionally, it is the same size and uses the same mounting procedure as the connection card, but only has the connection available on one end. See **Figure 21** below for a layout of the Custom Butterfly Card.

The Custom Butterfly Card is not required if the user has a Type 1 or Type 2 (as shown) laser mounted in the LDMOUNT. In that case, the connection card is used.

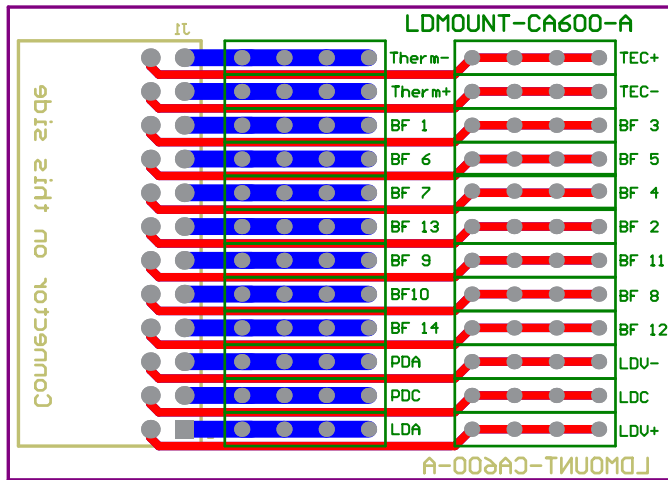

Figure 21. Layout of the Custom Butterfly Card.

Figure 21 above shows the connections available on the Custom Butterfly Card. The red lines connect all of the holes that are found on that line. For example, the TEC+ has four available connection holes (outlined by a green box to the left of the TEC+ label) that are all tied together. These four holes are also tied to the connection header on the left-hand side of the figure. This labeling/connection scheme, four connection holes outlined with green to the left of the label, is common for all available connections. In order to make the required connections, the user must solder wires up to 22 gauge between the holes. It is recommended to use solid core wires when making connections.

As an example, **Figure 22** shows a Custom Butterfly Card wired for a standard Type 1 Laser, with **Figure 23** showing the required connections for reference below.

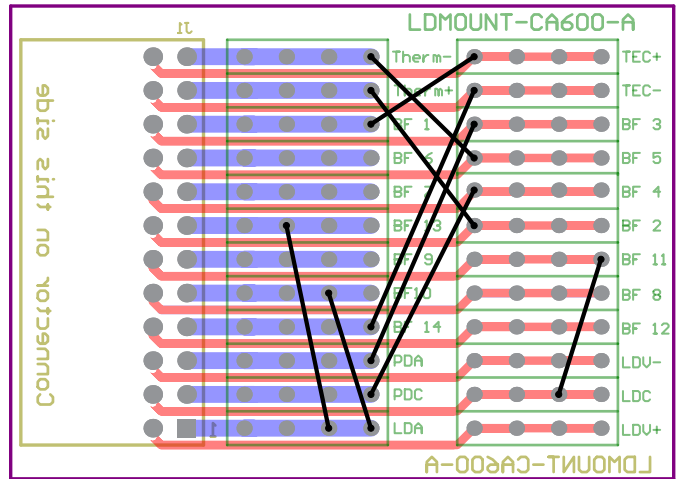

Figure 22. Custom Butterfly Card wired for a Type 1 laser.

Working down the left (blue) column of connections:

- Therm- is connected to butterfly pin (BF) 5
- Therm+ is connected to BF 2
- BF 1 is connected to TEC+
- BF13 is connected to LDA
- BF10 is connected to LDA
- BF 14 is connected to TEC-
- PDA is connected to BF 3
- PDC is connected to BF4

Working down the right (red) column of connections, the only connection that hasn't already been described is:

- BF 11 to LDC

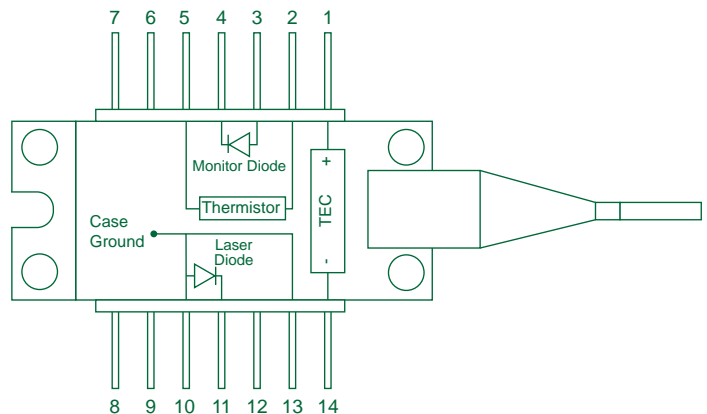

Figure 23. Standard Type 1 Laser Diode schematic.

These connections match exactly the schematic for the standard type 1 laser diode. For any given pinout of a butterfly package, the Custom Butterfly Card can be wired to match.

TROUBLESHOOTING

PROBLEM	POTENTIAL CAUSES	SOLUTIONS
LDMOUNT will not allow current from the laser driver to reach the laser.	Interlock circuit is not shorted.	<ol style="list-style-type: none"> 1. If an active Interlock circuit is set up, ensure that the connector is firmly seated in the Interlock port. 2. If no active Interlock circuit is set up, ensure that the shorting device shipped with the unit is firmly seated in the Interlock port.
	TEC Bypass switch is set to "Active," and no TEC device is connected.	<ol style="list-style-type: none"> 1. If using a TEC controller, ensure that it is properly plugged into the TEC 9-pin DSUB port on the side of the LDMOUNT. 2. If not using a TEC controller, put the TEC Bypass switch to "Bypass."
Diode laser will not turn on.	Connection card is incorrectly installed.	Look at the bottom side of the LDMOUNT, and through the viewing window on the access cover, ensure that the laser type being used matches the label on the connection card. If it does not, power down and unplug the TEC controller and/or the LDD connections to the LDMOUNT. Next, remove the access cover by unscrewing the two screws securing it, and re-seat the connection card such that the proper laser type is visible through the viewing window.
	Incorrect current source setup.	With grounded LDA lasers, the LDMOUNT needs negatively driven current to the LDC (with respect to the LDA). If the current is driven positively, the diode clamp between the LDA/LDC will not allow current to the laser.
Stable temperature is indicated on the TEC controller, but laser parameters (power, wavelength, etc.) are fluctuating.	Poor thermal conductivity between the diode laser butterfly package and the LDMOUNT.	Ensure that the butterfly package is firmly seated on the LDMOUNT via the four securing screws. If it is not, tighten these screws. If the diode laser continues to fluctuate, put a layer of thermal paste between the bottom of the butterfly package and the LDMOUNT.

IF THE SOLUTIONS ABOVE DO NOT SOLVE THE PROBLEM,
PLEASE CONTACT WAVELENGTH TECHNICAL SUPPORT.
techsupport@teamwavelength.com

CABLE SPECIFICATIONS

WCB319 - TC LAB LDMOUNT CABLE

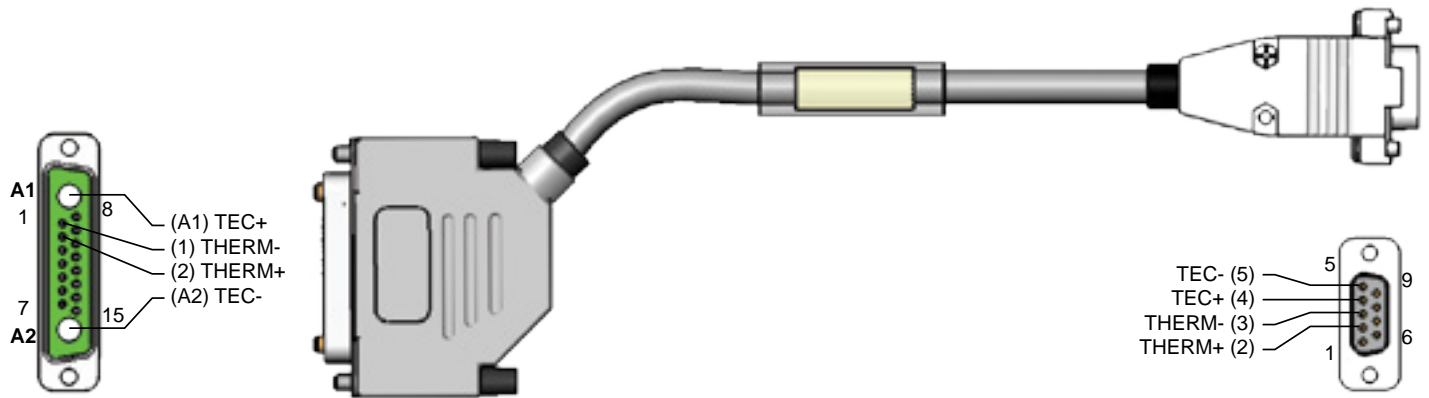

WCB316 - LFI3751 LDMOUNT CABLE

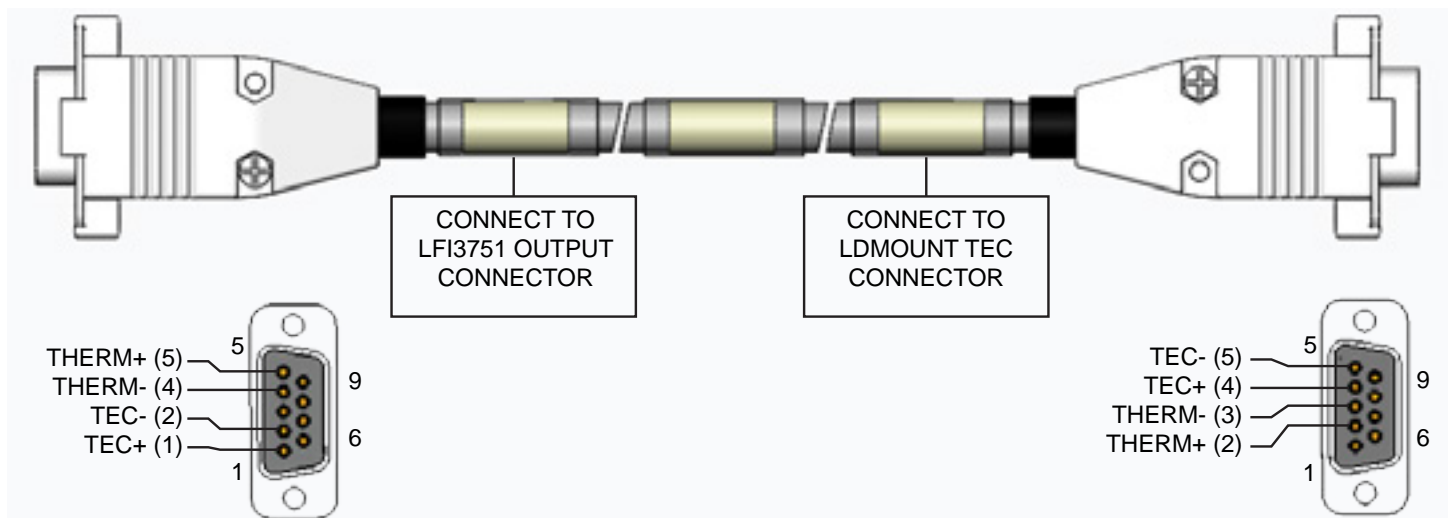

All cables are 36 inches [914.4 mm] in length. All tolerances are $\pm 5\%$.

WCB317 - WTC LDMOUNT CABLE

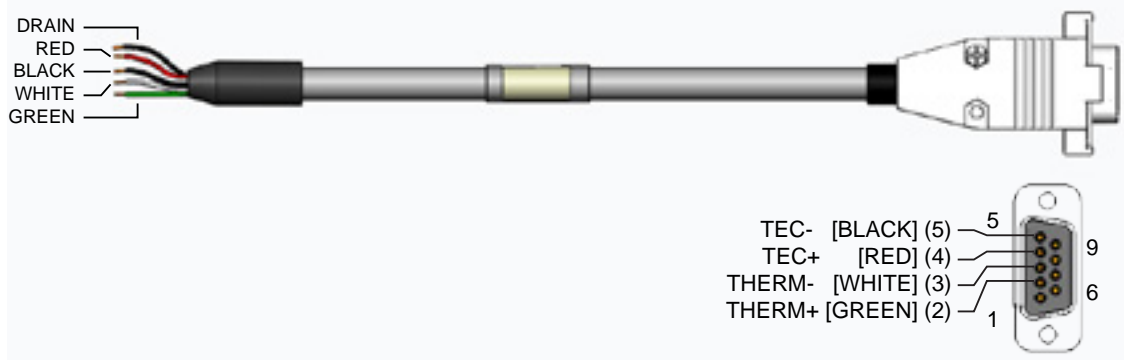

WCB318 - WLD LDMOUNT CABLE

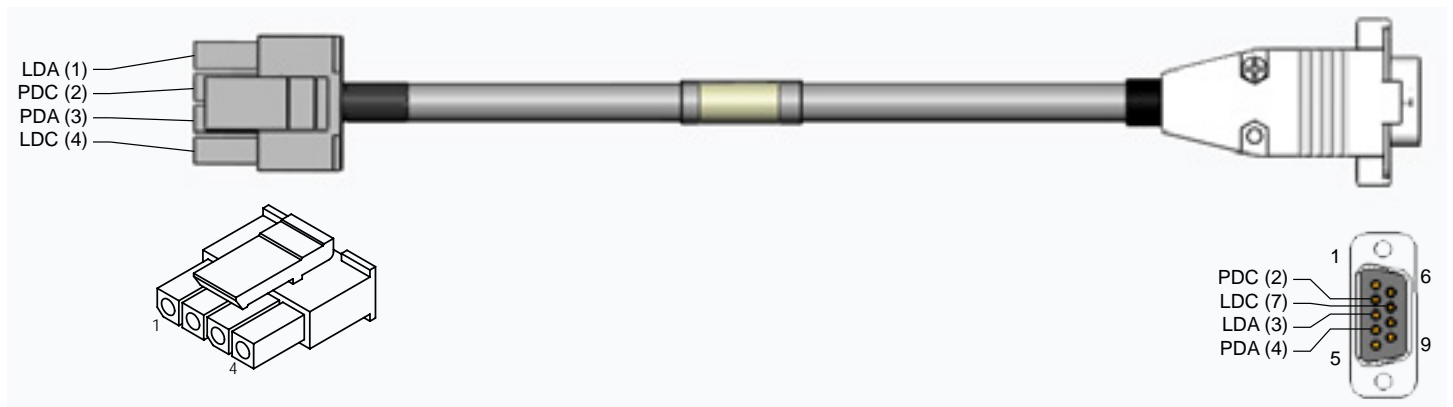

WCB320 - LDTC SERIES LDMOUNT CABLE

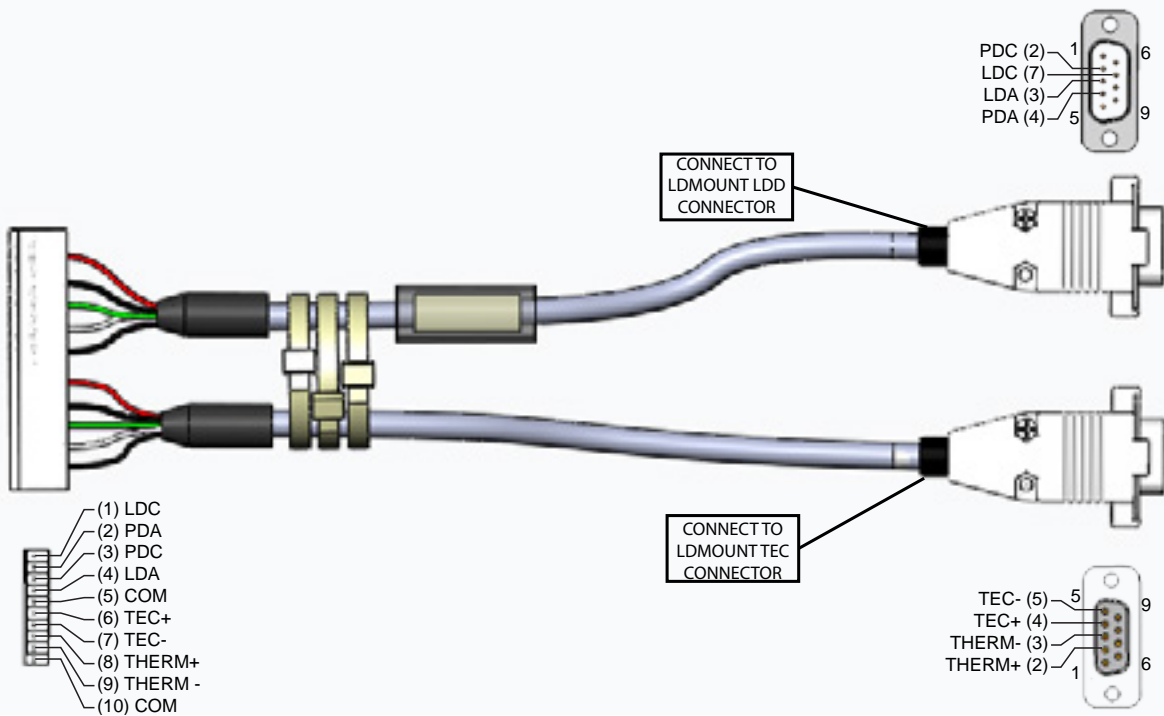

All cables are 36 inches [914.4 mm] in length. All tolerances are $\pm 5\%$.

WCB321 - PLD5K-CH LDMOUNT CABLE

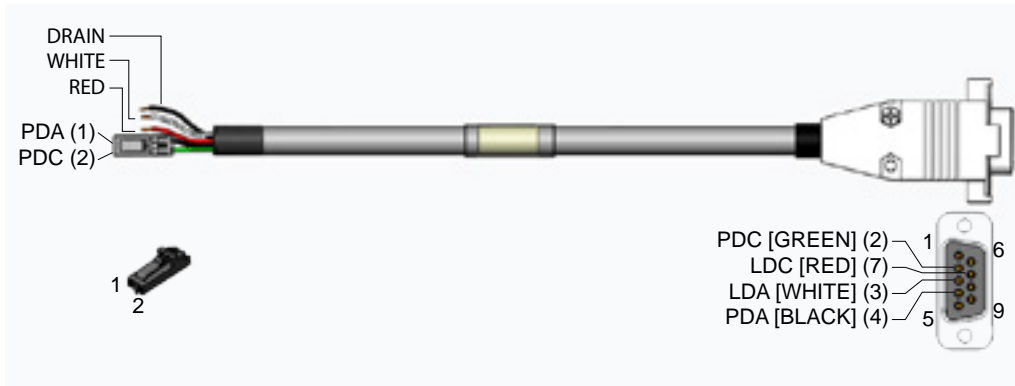

THE LDMOUNT HAS A CURRENT LIMIT OF 5A. THE PLD10K-CH CAN BE USED WITH THE LDMOUNT AS LONG AS THE CURRENT LIMIT IS SET SUCH THAT NO MORE THAN 5A WILL BE OUTPUT TO THE LDMOUNT. EXCEEDING 5A CAN DAMAGE THE LDMOUNT AND LASER.

WCB322 - PTC2.5K-CH & PTC5K LDMOUNT CABLE

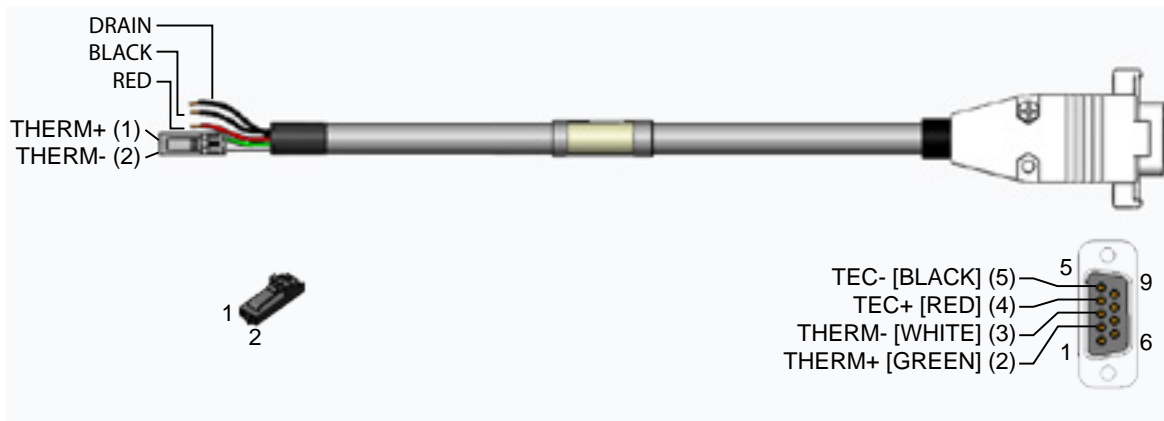

THE LDMOUNT HAS A CURRENT LIMIT OF 5A. THE PTC10K-CH CAN BE USED WITH THE LDMOUNT AS LONG AS THE CURRENT LIMIT IS SET SUCH THAT NO MORE THAN 5A WILL BE OUTPUT TO THE LDMOUNT. EXCEEDING 5A CAN DAMAGE THE LDMOUNT AND LASER.

All cables are 36 inches [914.4 mm] in length. All tolerances are $\pm 5\%$.

MECHANICAL SPECIFICATIONS

PARAMETER	VALUE	UNITS
Size	4 x 4 x 1.9 (101.6 x 101.6 x 48.26)	inches (mm)
Weight	1.15 (0.52)	lbs (kg)

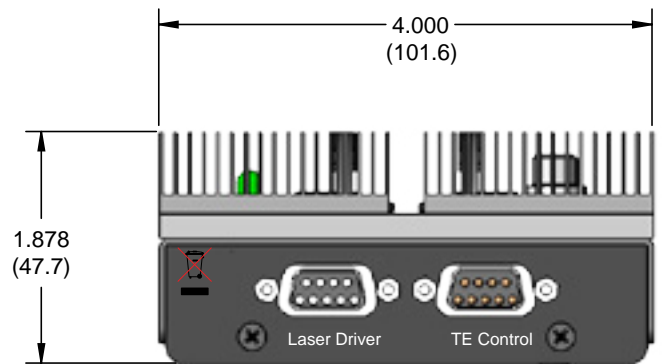
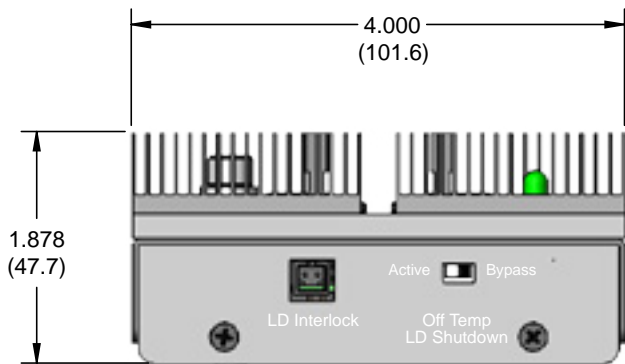
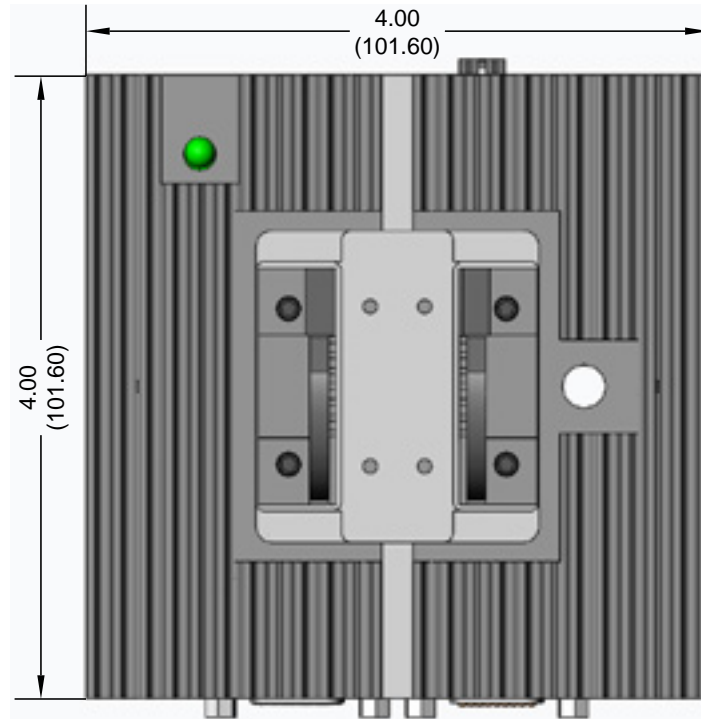

Figure 24. Mechanical Drawings of LDMOUNT. Top View (Top Center), Interlock/Bypass Side (Lower Left), and 9-pin DSUB Side (Lower Right).

Dimensions in inches (mm); Tolerance $\pm 5\%$

CERTIFICATION AND WARRANTY

CERTIFICATION

Wavelength Electronics, Inc. (Wavelength) certifies that this product met its published specifications at the time of shipment. Wavelength further certifies that its calibration measurements are traceable to the United States National Institute of Standards and Technology, to the extent allowed by that organization's calibration facilities, and to the calibration facilities of other International Standards Organization members.

WARRANTY

This Wavelength product is warranted against defects in materials and workmanship for a period of one (1) year from date of shipment. During the warranty period, Wavelength will, at its option, either repair or replace products which prove to be defective.

WARRANTY SERVICE

For warranty service or repair, this product must be returned to the factory. An RMA is required for products returned to Wavelength for warranty service. The Buyer shall prepay shipping charges to Wavelength and Wavelength shall pay shipping charges to return the product to the Buyer upon determination of defective materials or workmanship. However, the Buyer shall pay all shipping charges, duties, and taxes for products returned to Wavelength from another country.

LIMITATIONS OF WARRANTY

The warranty shall not apply to defects resulting from improper use or misuse of the product or operation outside published specifications. No other warranty is expressed or implied. Wavelength specifically disclaims the implied warranties of merchantability and fitness for a particular purpose.

EXCLUSIVE REMEDIES

The remedies provided herein are the Buyer's sole and exclusive remedies. Wavelength shall not be liable for any direct, indirect, special, incidental, or consequential damages, whether based on contract, tort, or any other legal theory.

REVERSE ENGINEERING PROHIBITED

Buyer, End-User, or Third-Party Reseller are expressly prohibited from reverse engineering, decompiling, or disassembling this product.

NOTICE

The information contained in this document is subject to change without notice. Wavelength will not be liable for errors contained herein or for incidental or consequential damages in connection with the furnishing, performance, or use of this material. No part of this document may be translated to another language without the prior written consent of Wavelength.

SAFETY

There are no user-serviceable parts inside this product. Return the product to Wavelength Electronics for service and repair to ensure that safety features are maintained.

LIFE SUPPORT POLICY

This important safety information applies to all Wavelength electrical and electronic products and accessories:

As a general policy, Wavelength Electronics, Inc. does not recommend the use of any of its products in life support applications where the failure or malfunction of the Wavelength product can be reasonably expected to cause failure of the life support device or to significantly affect its safety or effectiveness. Wavelength will not knowingly sell its products for use in such applications unless it receives written assurances satisfactory to Wavelength that the risks of injury or damage have been minimized, the customer assumes all such risks, and there is no product liability for Wavelength. Examples of devices considered to be life support devices are neonatal oxygen analyzers, nerve stimulators (for any use), auto-transfusion devices, blood pumps, defibrillators, arrhythmia detectors and alarms, pacemakers, hemodialysis systems, peritoneal dialysis systems, ventilators of all types, and infusion pumps as well as other devices designated as "critical" by the FDA. The above are representative examples only and are not intended to be conclusive or exclusive of any other life support device.

REVISION HISTORY

DOCUMENT NUMBER: LDMOUNT-5A400

REV.	DATE	CHANGE
A	June 2017	Initial Release



**WAVELENGTH
ELECTRONICS**

51 Evergreen Drive
Bozeman, Montana 59771

406-587-4910 (tel)
406-587-4911 (fax)



Sales & Tech Support
sales@teamwavelength.com
techsupport@teamwavelength.com