

*This product is sold  
and supported  
in the USA by*



**LASER LAB SOURCE**  
marketplace for **Scientists & Engineers**

**contact@LaserLabSoure.com**

**800.887.5065**

LASER DIODE DRIVERS | TEMPERATURE CONTROLLERS  
Simply Advanced Control for Your Cutting Edge Design



**WAVELENGTH**  
ELECTRONICS

# ***MPT***

# ***SERIES***

## ***DATA SHEET***

**Caution: To operate this controller safely,  
use the Safe Operating Area Design Tool  
online at**

[www.teamwavelength.com/support/calculator/soa/soatc.php](http://www.teamwavelength.com/support/calculator/soa/soatc.php)

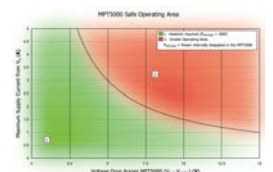

P O Box 865, Bozeman, MT 59771 • Phone (406) 587-4910 • Fax (406) 587-4911  
email: [sales@teamwavelength.com](mailto:sales@teamwavelength.com) • WEB: [www.teamwavelength.com](http://www.teamwavelength.com)

## TABLE OF CONTENTS

Features.....	2
Customer Service / Warranty.....	2
Optimize Your MPT.....	3
Quick Start.....	3
Pin Descriptions.....	5
Operating Instructions.....	7
Mechanical Dimensions.....	10
MPT Input / Output Cable Diagram.....	10

### FEATURES

The MPT temperature controller offers many unique features. These include:

- Excellent Temperature Stability
- Single supply operation: +5V to +15V  
(Contact factory for higher voltage operation)
- 2.5 Amp, 5.0 Amp, 7.5 Amp and 10 Amp models
- Linear Bipolar Output
- Operates with Thermistors, IC sensors or RTDs
- Temperature Setpoint, Proportional Gain, and TE Limit Current are user adjustable
- PID control loop
- Analog input for remote control
- Operates Thermoelectric Modules  
(Contact Factory for Resistive Heater Operation)

The **MPT** series of linear, bipolar temperature controllers operates from +5V to +15V, (contact factory for operation up to +30V) making them ideal for applications that require high compliance voltages. For maximum flexibility, the controllers interface to thermistors, IC sensors, or RTD's. Twelve-turn trimpots control temperature setpoint and the Proportional Gain term. The TE Current Limit is also user adjustable.

NOTE: Master / Slave mode for higher current operation has been phased out after Revision D (9/2003).

### CUSTOMER SERVICE / WARRANTY

If you have any questions or comments, please call our technical staff at (406) 587-4910. Our hours are 8:00a.m. to 5:00p.m. MT.

Wavelength warrants this product for 90 days against defects in materials and workmanship when used within published specifications. This warranty extends only to purchaser and not to users of purchaser's products. If Wavelength receives written notice of such defects during the warranty period, we will either repair or replace products which prove to be defective. It is purchaser's responsibility to determine the suitability of the products ordered for it's own use. Wavelength makes no warranty concerning the fitness or suitability of its products for a particular use or purpose; therefore, purchaser should thoroughly test any product and independently conclude its satisfactory performance in purchaser's application. No other warranty exists either expressed or implied, and consequential damages are specifically excluded.

All products returned must be accompanied by a Return Material Authorization (RMA) number obtained from the Customer Service Department. Returned product will not be accepted for credit or replacement without our permission. Transportation charges or postage must be prepaid. All returned products must show invoice number and date and reason for return.

## OPTIMIZE YOUR MPT

### POWER SUPPLY AND NOISE:

The control electronics are designed for low noise operation. The power supply you select will directly affect the noise performance of the controller. We recommend using regulated linear supplies for optimum performance. The following table details power supplies from Power One that properly operate the MPT series. You can contact the California plant at 1-(800) 678-9445:

Module	+5V	+12V	+15V	+24V
MPT-2500	HB5-3/OVP-A	HC12-3.4-A	HC15-3-A	HN24-3.6-A
MPT-5000	HC5-6/OVP-A	HN12-5.1-A	HD15-6-A	HE24-7.2-A
MPT-10000	HD5-15/OVP-A	HE12-10.2-A	F15-15-A	F24-12-A

Depending on your requirements, you may be able to use a switching power supply. Each case must be evaluated as a switching power supply will affect noise, transient, and stability performance.

### GROUNDING:



**CAUTION:** If you plan to operate the MPT with an MPL, you may need to use separate power supplies. If the TE cooler or thermistor is connected to the laser diode, you must use two separate power supplies and let each float independent of the other.

## QUICK START

The following is a sketch of the components you will need to operate the MPT, and a rough connection diagram. Much more detail is included in the PIN DESCRIPTION section, and you should review the entire manual before operating your TE module with the MPT. (Contact the Factory for Resistive Heater Operation.)

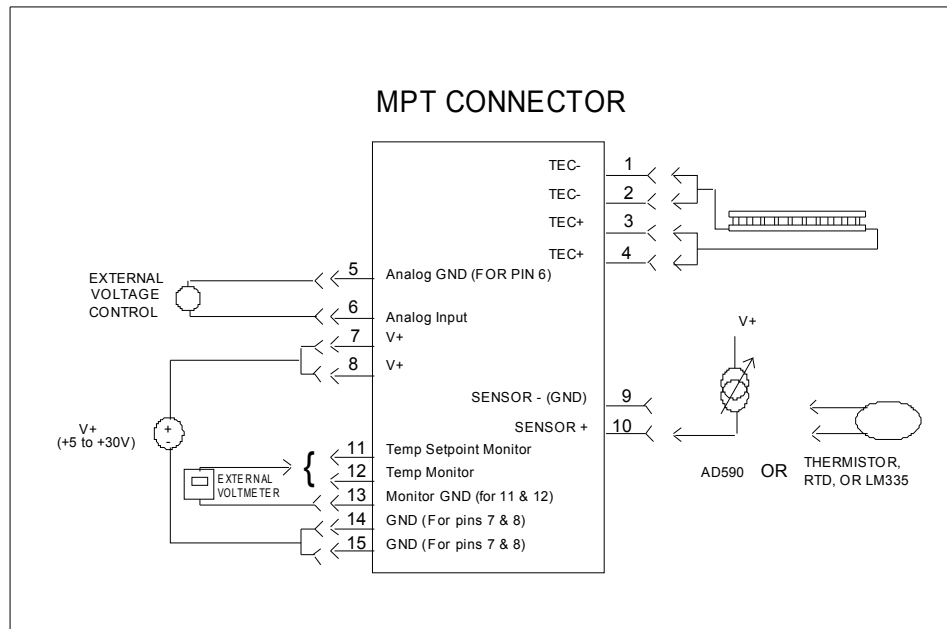
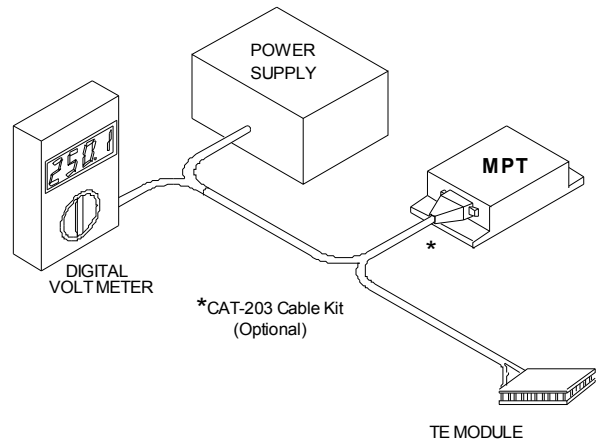

# MPT TEMPERATURE CONTROLLER ELECTRICAL SPECIFICATIONS

Model Number	MPT-2500*	MPT-5000*	MPT-10000*
<b>Temperature Control</b>			
Temp. Control Range, ①	-99 to +150°C	-99 to +150°C	-99 to +150°C
Short Term Stability, 1 hr. ②	< 0.002°C	< 0.003°C	< 0.005°C
Long Term Stability, 24 hr. ②	< 0.005°C	< 0.005°C	< 0.008°C
<b>TEC Output</b>			
Bipolar Output Current	<b>± 2.5 A</b>	<b>± 5 A</b>	<b>±10 A</b>
Compliance Voltage ③	See Note ③	See Note ③	See Note ③
Maximum Output Power	60W	120W	240W
Maximum Internal Power Dissipation	15W	30W	60W
Current Limit Range (Internal Trimpot Selectable)	0 - 2500 mA	0 - 5000 mA	0 - 10000 mA
Control Loop	PID	PID	PID
<b>Temperature Sensors</b>			
Thermistor Types (2 wire)	NTC	NTC	NTC
Thermistor Sensing Current	10 µA & 100 µA	10 µA & 100 µA	10 µA & 100 µA
Thermistor Range	1 kΩ - 500 kΩ	1 kΩ - 500 kΩ	1 kΩ - 500 kΩ
IC Sensor Types ④	AD590, LM335	AD590, LM335	AD590, LM335
IC Sensor Bias (LM335)	1 mA	1 mA	1 mA
RTD Types (2 wire)	100, 500 or 1kΩ	100, 500 or 1kΩ	100, 500 or 1kΩ
RTD Sensor Current	1 mA, 10 mA	1 mA, 10 mA	1 mA, 10 mA
Temp Setpoint Monitor vs. Temp Monitor Accuracy	< 2 %	< 2 %	< 2 %

## MPT GENERAL SPECIFICATIONS

<b>Power Requirements</b> ① ③ ⑤ +5 to +15 VDC (Contact factory for higher voltage operation.)	<b>Weight</b> < 0.7 lbs	<b>Connectors</b> 15 pin D-sub plug (cable needs female receptacles)
<b>Supply Current</b> MPT's Maximum TE Output Current plus 200 mA @ V+	<b>Operating Temperature</b> 0 to +50°C	<b>Warm-up</b> 1 hour to rated accuracy
<b>Size (H x W x D)</b> 1.0" x 3.55" x 3.5" (MPT-2500 and MPT-5000) 1.0" x 3.55" x 5.5" (MPT-10000)	<b>Storage Temperature</b> -40 to +50°C	<b>Power Indicator</b> Green LED

- ① Temperature Range depends on the physical load, sensor type, supply voltage, and TE module or resistive heater used. Operating with +5V input will limit the setpoint voltage to 2.5V to 3.5V, thus limiting the temperature range.
- ② Stability quoted for a typical 10 kΩ thermistor at 100 µA sensing current.
- ③ Compliance Voltage will vary depending on input voltages ( $V_s$ ) and drive current. Use the following table to determine compliance voltage:

Current Range	Compliance Voltage
200 mA	$V_s - 0.6$ V
2.5 A	$V_s - 2.0$ V
5.0 A	$V_s - 3.0$ V
10.0 A	$V_s - 5.0$ V

- ④ AD590 requires an external bias voltage.
- ⑤ If thermistor and laser diode are case common, the laser diode driver and TE controller power supplies must be isolated from each other.

\* These specifications are for Revision E & F (introduced 9/2003, 3/2005 respectively). Revision D specs were:

Short Term Stability, 1 hr. ②	< 0.005°C	< 0.005°C	< 0.005°C
Long Term Stability, 24 hr. ②	< 0.008°C	< 0.008°C	< 0.008°C
Compliance Voltage ⑥	>± 24 V	>± 24 V	>± 24 V
Current Limit Range (Internal Jumper Selectable, +/- 2% FS accuracy, 20% FS increments)			
Temp Setpoint Monitor vs. Temp Monitor Accuracy	< 5 %	< 5 %	< 5 %

- ⑥ Compliance Voltage will vary depending on input voltages. A maximum compliance voltage of ± 24 volts will be obtained with +30 volt input. A minimum compliance voltage of ± 2.0 volts will be obtained with +5 volt input (Rev D).

## PIN DESCRIPTIONS

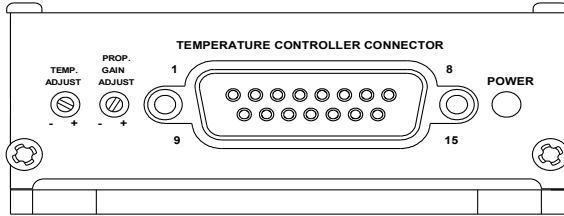

### Pins 1, 2 TEC -

These pins sink the current returned from the TE Cooler (when using NTC sensors).

### Pins 3, 4 TEC +

These pins supply the current to the TE Cooler (when using NTC sensors). **CAUTION: If operating from a +5V supply, the output compliance voltage will be less than ± 5V (± 2.5 to ± 3.5 V), limiting the output power of the MPT.**

### Pin 5 Analog GND

This pin is the ground connection for the analog input signal.

### Pin 6 Analog Input

This pin is the analog input. It can be used for remote, external control of the Temperature Setpoint. The transfer function is 2V/V. The Analog Input sums with the temperature setpoint adjust trimpot. The sum of the voltages is not to exceed V+. **Tie pins 5 & 6 together if you are not using this Analog Input.**

### Pins 7, 8 V+

These pins along with pins 14 and 15 (GND) provide power to the control electronics and the TE Cooler output stage.

### Pin 9 SENSOR- (GND)

This pin is used as the thermistor, IC sensor, or RTD current source return pin. This pin is at ground potential but should not be used for anything other than the sensor current source return.

### Pin 10 SENSOR+

This pin is used to source the thermistor, IC sensor, or RTD reference current through the temperature sensor. An internal jumper in the unit will select between a 10µA, 100 µA, and 1 mA reference current.

### Pin 11 TEMP SETPOINT MONITOR

This output is used in setting the temperature setpoint of the sensor. This voltage will range from 0-5 V and should closely match the voltage across the sensor when it is at the desired temperature. **CAUTION: If operating from a +5V supply, the setpoint monitor voltage will be less than 5V (2.5 to 3.5 V), limiting the temperature range of the MPT.**

## MPT Connector (15 pin D-sub)

Pin #	
1	TEC -
2	TEC -
3	TEC +
4	TEC +
5	Analog GND (for pin 6)
6	Analog Input
7	V+
8	V+
9	Sensor - (GND)
10	Sensor +
11	Temp Setpoint Monitor
12	Temp Monitor
13	Monitor GND (For pins 11 & 12)
14	GND (For pins 7 & 8)
15	GND (For pins 7 & 8)

### Pin 12 TEMP MONITOR

This output is used to monitor the voltage, and therefore temperature, of the sensor. When controlled, the TEMP MONITOR voltage will closely match the voltage set at pin 11 (TEMP SETPOINT MONITOR).

### Pin 13 Monitor GND - LOW CURRENT ONLY

This pin provides ground potential to be used with the monitor outputs, pins 11 and 12. This ground is started with the circuit ground to provide the most accurate monitor measurement.

### Pins 14, 15 Supply GND

These pins, along with pins 7 and 8 (V+) provide power to the control electronics and provides power to the TE Cooler output. This is the only ground connection designed as a high current return.

## TRIMPOT ADJUSTMENTS

### TEMPERATURE SETPOINT ADJUST

This 12 turn trimpot adjustment varies the temperature setpoint. Turning the trimpot adjust clockwise increases the setpoint voltage. During stable operation, this voltage will closely match the Temp Monitor voltage.

### PROPORTIONAL GAIN ADJUST

This 12 turn trimpot adjusts the proportional gain for the PID control loop. Turning the trimpot adjust clockwise increases proportional gain, and the PID dampening.

$$\text{Rev E \& F: } P_{GAIN} = \frac{R_{PROP}}{3.92 k \Omega} \times M$$

	M	P = 26 (default)
MPT2500	1	6 CW turns
MPT5000	2	3 CW turns
MPT10000	4	1.5 CW turns

Rev D: Default setting is ¼ turn back from the fully CW position ( $P_{GAIN} = 26$ )

## SELECTABLE ADJUSTMENTS

Several jumpers and one trimpot are used to configure the system to the application. These settings select Current Limit, Sensor Type, and the Sensor Current. The lid must be removed to access the jumpers and trimpot.

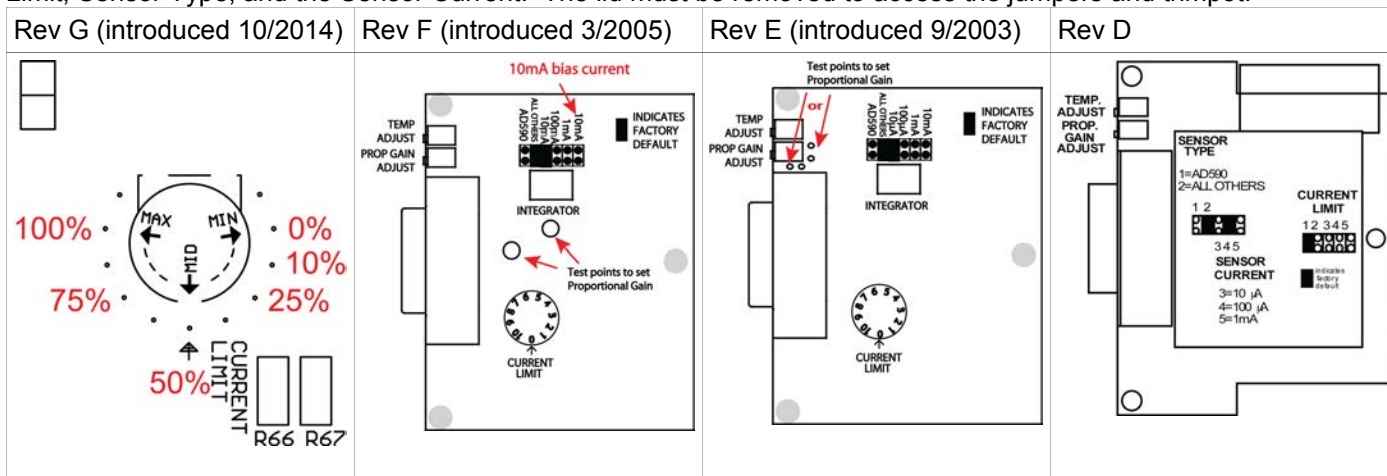

### INTERNAL JUMPER SELECTION

**Sensor Type:** Factory default is for operation with Thermistors, RTD, or LM335. If you are using an AD590, move the jumper from “ALL OTHERS” to “AD590”. An AD590 must be biased by at least +8V. If V+ exceeds +8V, it can be used for bias. Use pin 10 for the other AD590 connection, and do not connect pin 9. (See the Quick Connection diagram on page 3.)

**Sensor Current:** The resistance of the sensor you choose, in conjunction with the sensor current, must produce a voltage between 0 V and 5 V in order to be used in the control loop. The 10  $\mu$ A and 100  $\mu$ A sensor currents are used with thermistors. The 1 mA sensor current is used with the LM335 IC Sensor and 500 or 1000 $\Omega$  RTDs. The 10mA bias current (available on Rev. E) is for 100 $\Omega$  RTDs.

$$\text{The voltage produced by your sensor is given by: } V = R_{\text{SENSOR}} * I_{\text{SENSOR}}$$

**Current Limit:** Factory default is 0 A for the Current Limit Trimpot. Rotate this Trimpot clockwise to the desired maximum output current. The following charts detail the current limit settings available for each unit.

PRODUCT REVISION	CURRENT LIMIT TRIMPOT POSITIONS											
Rev. G (Introduced 10/2014.)	Tick Marks	0	1	2	3	4	5	6	7	8		
	MPT2500	0A	0.312A	0.625A	0.937A	1.25A	1.56A	1.87A	2.19A	2.5A		
	MPT5000	0A	0.4A	1A	1.6A	2.2A	2.8A	3.75A	4.3A	5A		
	MPT10000	0A	1A	2.5A	3.75A	5A	6.25A	7.75A	8.75A	10A		
Rev. E (Introduced 9/2003.) & Rev. F (introduced 3/2005.)		0	1	2	3	4	5	6	7	8	9	10
	MPT2500	0A	250mA	500mA	750mA	1A	1.25A	1.5A	1.75A	2A	2.25A	2.5A
	MPT5000	0A	500mA	1A	1.5A	2A	2.5A	3A	3.5A	4A	4.5A	5A
Rev. D (Each setting represents a 20% increment of full scale current.)			1	2	3	4	5					
	MPT2500		0.5A	1A	1.5A	2A	2.5A					
	MPT5000		1A	2A	3A	4A	5A					
	MPT10000		2A	4A	6A	8A	10A					

**Proportional Gain:** Measure resistance across the two test points labeled above to determine the gain setting. Factory default is a gain of 25.

For MPT2500, Resistance = Gain \* 4000; Default 100k $\Omega$   
 For MPT5000, Resistance = Gain \* 2000; Default 51k $\Omega$   
 For MPT10000, Resistance = Gain \* 1000; Default 25k $\Omega$

# OPERATING INSTRUCTIONS

## 1. VERIFY MAXIMUM POWER DISSIPATION OF MPT IS NOT EXCEEDED

The SOA (Safe Operating Area) curves combine the current, voltage, and power limit effects for the MPT. This curve illustrates the unsafe operating area where the MPT2500 can be damaged due to thermal stress on the output power stage. Figure 1 shows the SOA curve for the MPT2500 when the heatsink temperature is 35°C. As the heatsink temperature increases, the unsafe operating area increases. Notice this curve applies to any of the three MPT Temperature Controllers. Scale the y-axis to the maximum output current capacity of the MPT selected.

Online, SOA calculators are at <http://www.teamwavelength.com/support/calculator/soa/soatc.php>. You can vary heatsink temperature, power supply voltage, etc. to design a system that will not dissipate too much power in the MPT.

### Caution:

**Do not exceed the Safe Operating Area (SOA). Exceeding the SOA voids the warranty.**

To determine if the operating parameters fall within the SOA of the device, the maximum voltage drop across the controller and the maximum current must be plotted on the SOA curves.

These values are used for the example SOA determination:

$V_s = 12$  volts

$V_{load} = 5$  volts

$I_{load} = 1$  amp

Follow these steps:

1. Determine the maximum voltage drop across the controller,  $V_s - V_{load}$ , and mark on the X axis. (12volts - 5volts = 7 volts, Point A)
2. Determine the maximum current,  $I_{load}$ , through the controller and mark on the Y axis: (1 amp, Point B)
3. Draw a horizontal line through Point B across the chart. (Line BB)
4. Draw a vertical line from Point A to the maximum current line indicated by Line BB.
5. Mark  $V_s$  on the X axis. (Point C)
6. Draw the Load Line from where the vertical line from point A intersects Line BB down to Point C.

Refer to the chart shown below and note that the Load Line is in the Safe Operating Areas when used with the appropriate heatsink that keeps the heatsink temperature below 35°C. Online, SOA calculators are at

<http://www.teamwavelength.com/support/calculator/soa/soatc.php>.

MPT2500 Safe Operating Area

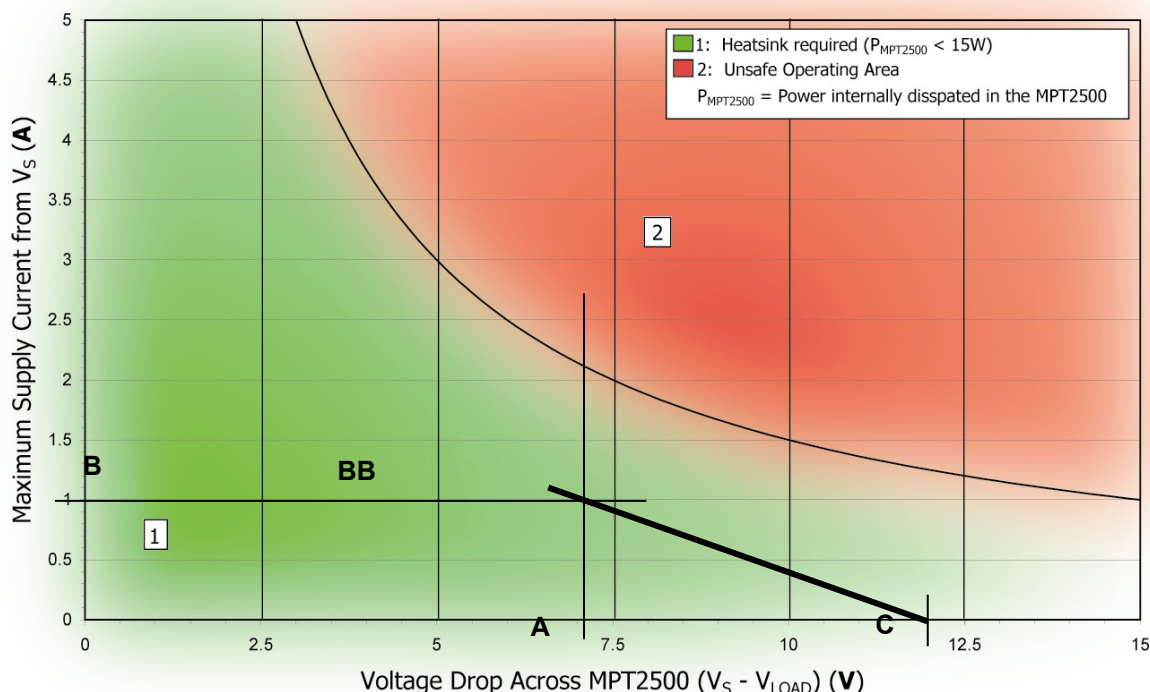



## 2. ESTABLISH THERMAL CONTROL

A heat sink must be properly attached to the MPT in order to remove heat from the module. The following drawing shows where the heat sensitive components are located. Thermally conductive grease should be used between the heatsink and the module for optimum performance.

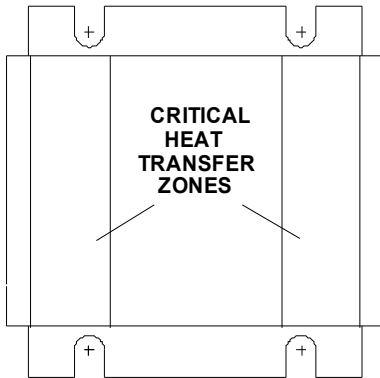

Use the SOA curves to determine the maximum power dissipated in the unit. Calculate the allowed rate of temperature increase with:

$$\text{RATE} = 50 / P_{\text{UNIT}} \text{ where Rate is in } ^\circ\text{C/W.}$$

For example, if  $P_{\text{UNIT}}$  is 60W, RATE is 50/60 or 0.83°C/W. Adding a safety factor, you should select a heatsink with 0.8°C/W rating.

## 3. CONFIGURING THE JUMPERS

### Sensor Type

Choose a sensor that allows control over the required range. Once a sensor type has been selected, set the Sensor Jumper to match. For AD590's, install a jumper in the location marked "AD590". For all other temperature sensors, install the jumper on the location marked "ALL OTHER SENSORS". NOTE: The current direction from TEC+ to TEC- is set up for NTC sensors (thermistors). If using an LM335, AD590, or RTD's, reverse the leads to the TE module from pins 1, 2 and 3, 4. [Current will flow from TEC- to TEC+, so "TEC-" will connect to the positive wire of the cooler, and vice versa].

### Sensor Current

The resistance of the sensor you choose, in conjunction with the sensor current, must produce a voltage between 0 and 5V in order to be used in the control loop. Install a jumper on one of the locations marked "10µA", "100µA", "1mA", or "10mA" based on the sensor you will use. Bias an LM335 using the 1mA sensor current. Use the 10µA or 100µA sensor current for thermistors. Use 10mA for 100Ω RTDs. The voltage produced by your sensor is given by:

$$V = R_{\text{SENSOR}} * I_{\text{SENSOR}}$$

### Limit Current

Based on the chart on page 6, select the limit current that does not exceed the maximum operating current of your TE module. Rotate the Current Limit Trimpot to this value.

## 4. CONNECTING POWER, SENSOR, AND THERMO-ELECTRIC MODULE

### Power (Pins 7, 8 and 14, 15)

The MPT operates from a single power supply. Connect a positive voltage to pins 7 and 8, and ground pins 14 and 15. When using the MPT-10000, ALWAYS connect to both pins 7 and 8, and pins 14 and 15 to avoid damage to the controller.

### Sensor (Pins 9 & 10)

Epoxy or otherwise fix the temperature sensor to the cooling plate in your application. Connect the sensor to pins 9 and 10. For sensors where polarity is important, pin 9 is Sensor -, and pin 10 is Sensor +.

### TE Cooler (pins 1, 2, 3, & 4)

Connect the thermo-electric cooler to pins 1, 2 and 3, 4. Make sure it is adequately connected to the cooling plate and heat sink. Properly transferring heat from the device is imperative. Make sure your heat sink is rated to remove the amount of heat required for your application. If enough heat is not removed from the device, it can go into thermal runaway where it cannot cool and might be damaged. When using the MPT-10000, ALWAYS connect to both pins 1 and 2, and pins 3 and 4 to avoid damage to the controller.

NOTE: The current direction is set up for NTC sensors (thermistors). While cooling, it flows from TEC+ (pins 3,4) to TEC- (pins 1,2). If using an LM335, AD590, or RTD's, reverse the cooler leads between pins 1, 2 and 3, 4. [Current will flow from TEC- to TEC+, so "TEC-" will connect to the positive wire of the cooler, and vice versa].

## 5. OPERATING TEMPERATURE

### Setpoint (Pin 11)

This voltage will depend on the sensor selected. Use one of the two following equations based on the sensor type you will be using.

#### Thermistors and RTD's

$$V_{\text{SETPOINT}} = I_{\text{REF}} * R \text{ (I}_{\text{REF}} \text{ is in amps and R is in ohms)}$$

"R" equals the resistance value of the sensor at the desired operating temperature. The reference current ( $I_{\text{REF}}$ ) will be 10mA, 1mA, 100µA, or 10µA

#### LM335 & AD590

$$V_{\text{SETPOINT}} = 2.730\text{V} + (0.010\text{V}/^\circ\text{C} * T_{\text{DESIRED}})$$

where  $T_{\text{DESIRED}}$  is the setpoint temperature in °C.

Monitor this setting on pin 11. Increase the voltage by rotating the setpoint potentiometer clockwise slowly. Watch the Temp Monitor (pin 12) voltage approach the Setpoint voltage with a time lag.

### Proportional Gain

The factory setting for the proportional gain is a gain of 26. This gain can be adjusted to optimize the system for overshoot and settling time. Turning this potentiometer clockwise increases the gain and dampens the output.

6. OPERATING WITH RESISTIVE HEATERS

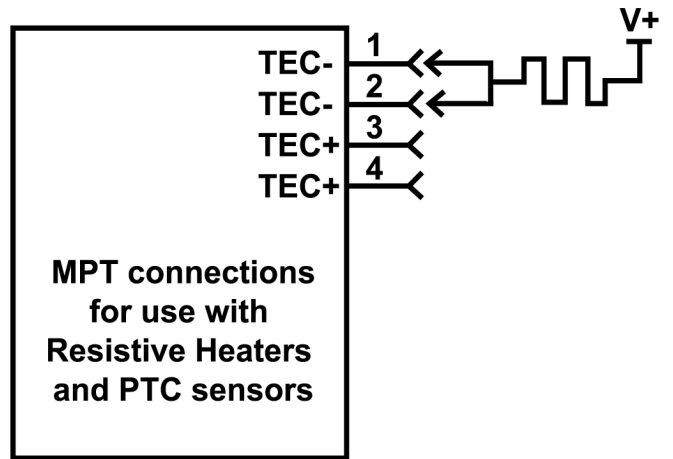
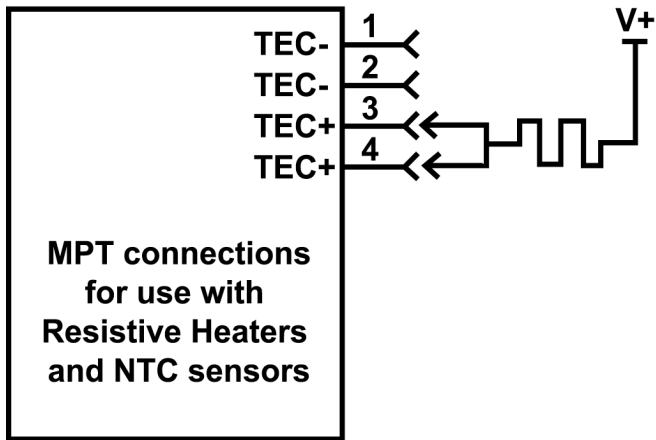

# MECHANICAL DIMENSIONS

## FIGURE A

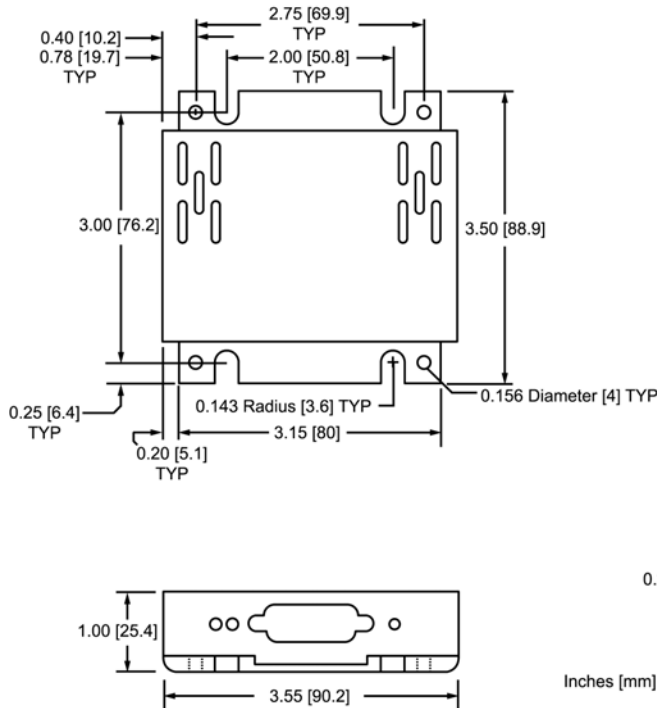

## FIGURE B

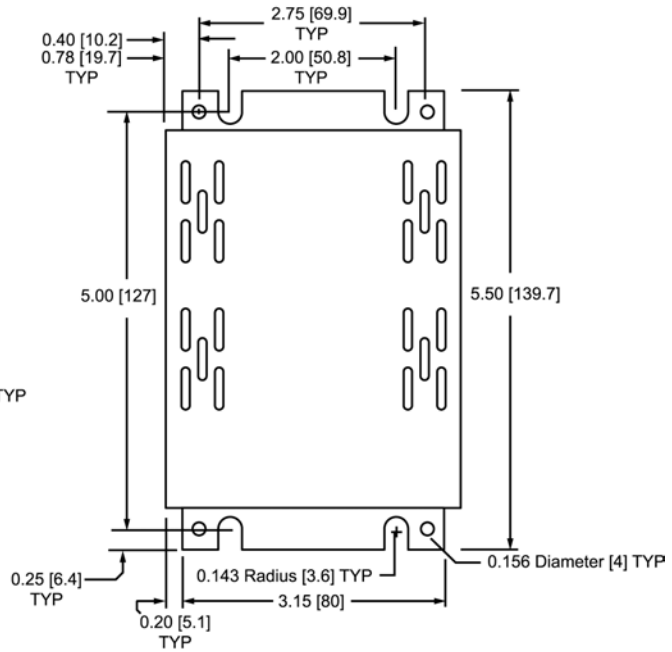

\* Tolerance on the mounting holes is +/- 0.020"

\* All Other Tolerances are +/-5%

MPT SERIES SELECTION GUIDE		FIG
MPT-2500	2.5 A Temperature Controller	A
MPT-5000	5 A Temperature Controller	A
MPT-10000	10 A Temperature Controller	B

### OPTIONAL ACCESSORIES AVAILABLE FOR SYSTEM DEVELOPMENT:

CKT-202A connector kit includes the appropriate 15 pin D-sub connector, hood and hardware.

#### WCB-101

A Cable Kit includes one meter of cable soldered to a mating connector on one end and unterminated on the other.

Connector Kit	CKT-202
Cable Kit	WCB-101

Precision thermistors for various temperature ranges are offered with detailed R-T charts for quick system integration.

MODEL	R @ 25°C	10 μA RANGE	100 μA RANGE
TCS-605	5 kΩ	-55°C to -2°C	-20°C to +33°C
TCS-610	10 kΩ	-45°C to +13°C	-8°C to +50°C
TCS-10K5	10 kΩ	-45°C to +13°C	-8°C to +50°C
TCS-620	20 kΩ	-35°C to +28°C	+6°C to +69°C
TCS-650	50 kΩ	-18°C to +49°C	+25°C to +92°C
TCS-651	100 kΩ	-6°C to +67°C	+41°C to +114°C

#### WCB-101 MPT I/O CABLE

#### CAT-203 MPT I/O CABLE

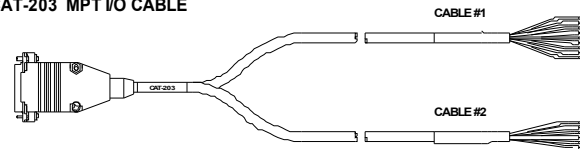

PIN	WIRE COLOR	CABLE #	FUNCTION
1	BLUE	2	TEC-
2	BLACK	2	TEC-
3	ORANGE	2	TEC+
4	RED	2	TEC+
5	GREEN/BLACK	1	Modulation GND (for pin 6)
6	ORANGE	1	Modulation Input
7	RED/BLACK	1	V+
8	RED	1	V+
9	GREEN	2	Sensor - (GND)
10	WHITE	2	Sensor +
11	WHITE/BLACK	1	Temp Setpoint Monitor
12	WHITE	1	Temp Monitor
13	GREEN	1	Monitor GND (for 11 & 12)
14	BLUE	1	GND (For pins 7 & 8)
15	BLACK	1	GND (For pins 7 & 8)