

*This product is sold
and supported
in the USA by*



LASER LAB SOURCE
marketplace for **Scientists & Engineers**

contact@LaserLabSource.com

800.887.5065

DATASHEET AND OPERATING GUIDE

LDT0520/LDT01020

Laser Diode & Temperature Controllers



FEATURES AND BENEFITS

- Small package size
- Single supply operation possible
- LD current range 500 mA or 1 A
- Compatible with Type A and B lasers
- Slow start laser diode protection
- Constant Current or Constant Power modes
- Adjustable laser diode current limit
- Brownout protection
- Drive up to ± 2.2 A of TEC current
- Internal or External setpoint control
- Failsafe setpoint default
- Ultra-stable PI control loop
- Separate Heat & Cool current limits

PROVEN RELIABILITY SAVES YOU TIME AND MONEY

The LDT Laser Diode and Temperature Controller combines the proprietary FL500 and ultra-stable WTC3243 in one compact and easy-to-use module. All the controls and indicators are onboard for simple plug-and-play operation.

APPLICATIONS

LDT modules are in use around the world providing trouble-free reliability in range finders, telecom laser modules, military-aerospace research and development, airborne metrology, academic research, laser diode LIV testers, and more.

POWER YOUR APPLICATION WITH THE RIGHT FEATURES

The popular FL500 is known for trouble-free operation. The current limit circuit cleanly clamps laser diode current without ringing or overshoot, and recovers without inducing a phase shift in a modulated laser signal.

The WTC3243 ultra-stable temperature control module is known for precision and reliability. Independent cooling- and heating-current limits allow the LDT to be used with thermoelectric coolers or resistive heaters, and either negative or positive temperature coefficient sensors.

CONTENTS

CONTENTS	PAGE
QUICK CONNECT GUIDE	2
PIN DESCRIPTIONS	5
ELECTRICAL SPECIFICATIONS	7
SAFETY & THERMAL DESIGN CONSIDERATIONS	9
OPERATING INSTRUCTIONS -- TEMP CONTROLLER	10
OPERATING INSTRUCTIONS -- LASER DRIVER	15
ADDITIONAL TECHNICAL INFORMATION	17
TROUBLESHOOTING -- TEMP CONTROLLER	22
TROUBLESHOOTING -- LASER DRIVER	23
MECHANICAL SPECIFICATIONS	25
CERTIFICATION AND WARRANTY	26

ORDERING INFORMATION

PART NO	DESCRIPTION
LDT0520	500 mA LD / ± 2.2 A TEC Controller
LDT01020	1.0 A LD / ± 2.2 A TEC Controller

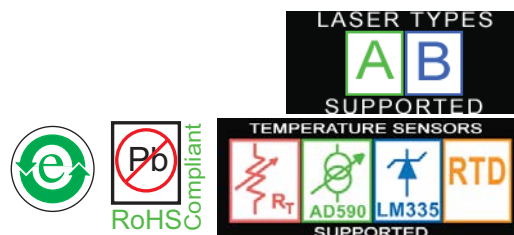

QUICK CONNECT GUIDE

LDT0020 Top View	page 2
LDT0020 Wiring Diagram	page 2
Laser Driver Test Load	page 3
Thermoelectric Test Load	page 4



IT IS IMPERATIVE THAT YOU VERIFY THE UNIT WILL OPERATE WITHIN THE INTERNAL HEAT DISSIPATION SAFE OPERATING AREA (SOA).

OPERATING THE CONTROLLER OUTSIDE THE SOA MAY DAMAGE OR DESTROY THE LDT0 AND/OR LOADS.

Visit the Wavelength Electronics website for the most accurate, up-to-date, and easy to use SOA calculator:

Laser Diode Drivers:

<http://www.teamwavelength.com/support/calculator/soa/soald.php>

Temperature Controllers:

<http://www.teamwavelength.com/support/calculator/soa/soatc.php>

The model number is stamped on the top cover of the module. If the top cover is missing, the model number can be identified by the number of FL500 chips on the circuit board: the LDT0520 has a single FL500 on the top; the LDT1020 has two FL500 chips—one on each side of the circuit board.

DIP Switch Functions

LDREF = Internal vs. External Laser Diode Setpoint
 CC | CP = Constant Current vs. Constant Power Control Mode
 TREF = Internal vs. External Temperature Setpoint



* DO NOT CHANGE SWITCH POSITIONS WHILE THE OUTPUT IS ENABLED; DOING SO MAY DAMAGE THE LOAD.

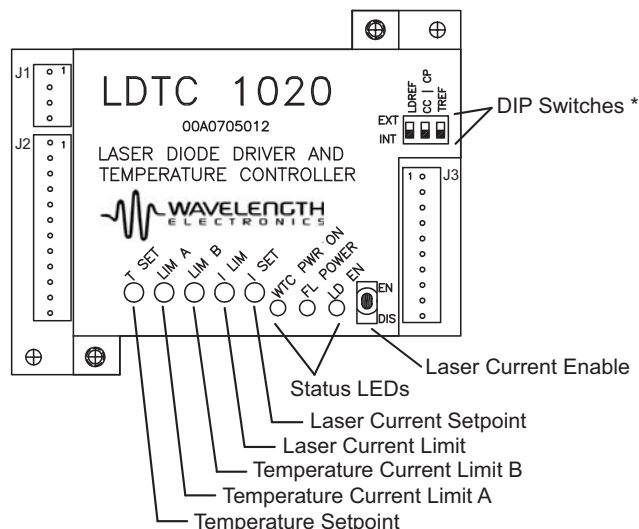
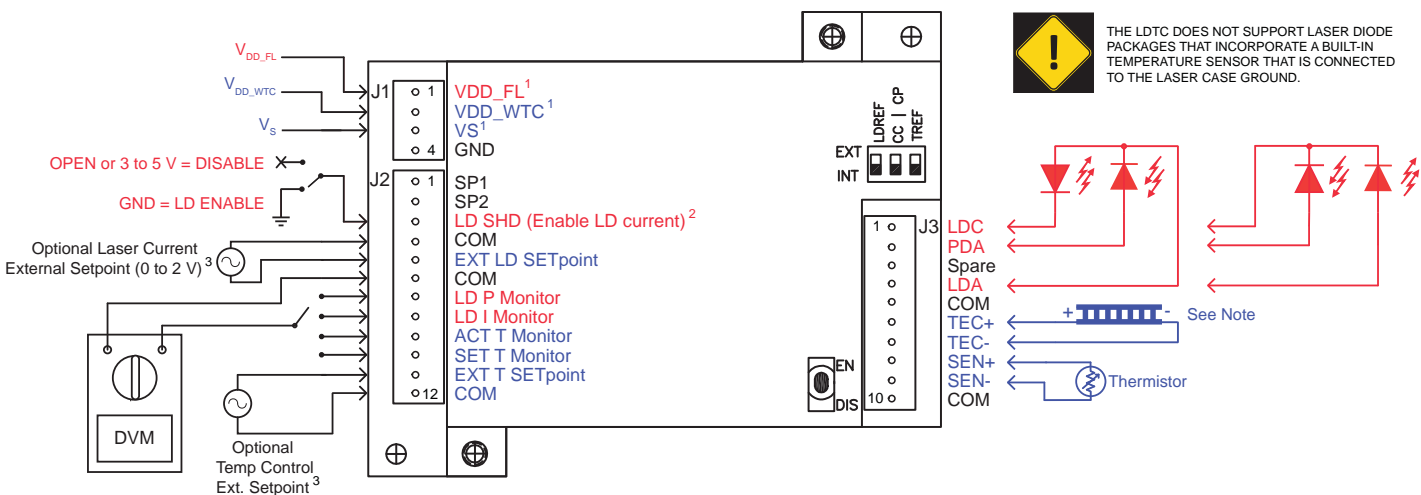

Figure 1. LDT0020 Top View

Figure 1 is the top view of the LDT0, illustrating the onboard switches and trimpots.

Figure 2 is the Quick Connect diagram for the LDT0020 Controllers with a laser diode, separate power supplies, and a thermoelectric cooler. This is the most common application for the LDT0020 Controllers.



1. V_{DD_WTC} , V_{DD_FL} , and V_S can be tied together if common voltage provides sufficient compliance for laser diode and thermoelectric loads. Separate V_S if higher compliance is required for the temperature controller load.
2. If using the LD SHD input, set the onboard Enable/Disable switch to Enable.
3. Refer to Electrical Specifications for input voltage range.

Figure 2. LDT0020 Quick Connect Wiring Diagram

The LDT0520 is compatible with Type A and Type B lasers, but will not drive Type C lasers; see **Figure 3**.

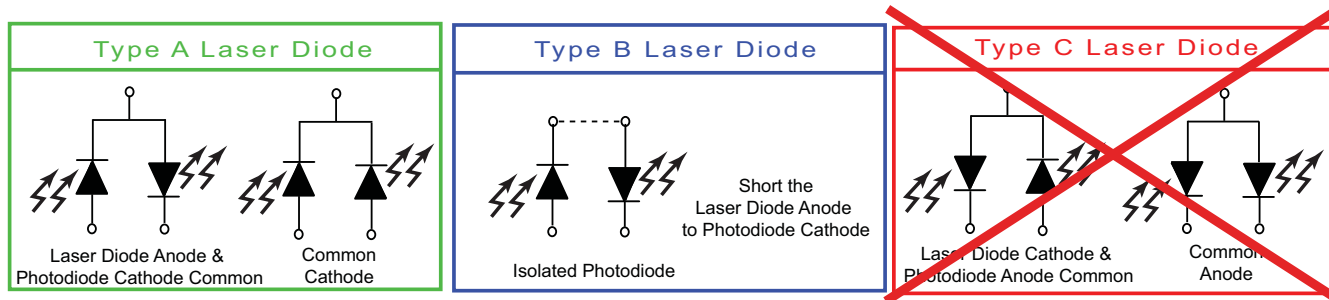

Figure 3. Laser Type Diagrams

For initial setup and configuration, we recommend using a simulated load while configuring the laser diode driver, until familiar with the controller operation. To pre-test or troubleshoot the temperature controller, please use the following recommended test loads.

RECOMMENDED LASER DRIVER TEST LOAD

For the laser diode driver, recommended simulated laser loads are shown in **Figure 4** and **Figure 5**. In Constant Current Mode, the setpoint correlates to the laser diode current flow and is measured by monitoring the current at I_{MON} . When setting I_{LIM} , turn the I_{LIM} trimpot fully counterclockwise (12 turns CCW). Then turn the setpoint trimpot fully clockwise (12 turns CW). While monitoring the I_{MON} voltage, turn the I_{LIM} trimpot CW until the desired voltage relative to current is reached. Then turn the setpoint trimpot CCW until the I_{MON} voltage is affected and stop. The limit is now set and the current can be adjusted within the limit range.

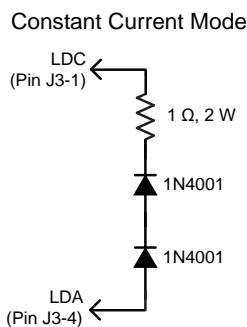
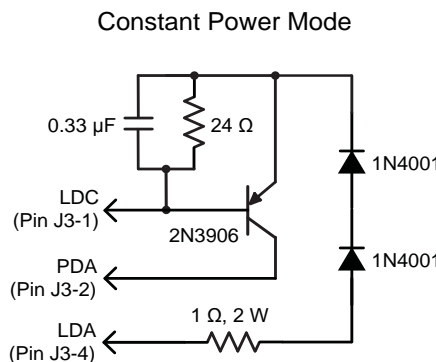

Figure 4. Constant Current Mode

In Constant Power Mode, the setpoint correlates to the photodiode feedback current, which represents a fraction of the light power emitted by the laser diode. Photodiode current is measured by monitoring P_{MON} .



The 24 Ω resistor typically produces approximately 30 mA laser driver current. Vary the resistor value to change the output current.

Figure 5. Constant Power Mode

NOTE: To determine the actual drive current, measure the voltage drop across the 1 Ω resistor. Do not insert an ammeter in series with the output circuit; doing so may cause instability in the control loop. To stay within the Safe Operating Area, V_s must not exceed 5 V.

RECOMMENDED THERMOELECTRIC TEST LOAD

For the temperature controller, recommended simulated thermoelectric and thermistor circuits are shown in **Figure 6** and **Figure 7**. Configuring the temperature controller using test loads is recommended for setting the thermoelectric controller limits or to check the temperature controller operation.

Thermal Test Load

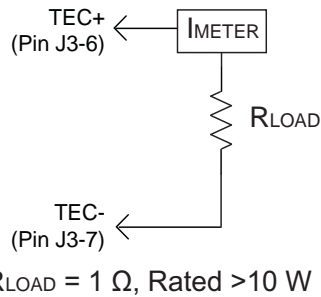
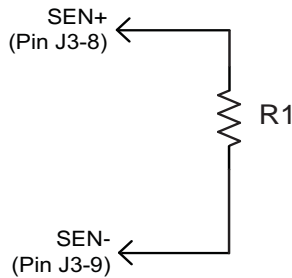

Figure 6. Simulated Thermoelectric Test Load

Simulated Thermistor



$R1 = 10 \text{ k}\Omega$, $\frac{1}{4} \text{ W}$ resistor

Figure 7. Simulated Thermistor

This circuit simulates a $10 \text{ k}\Omega$ thermistor operating at 25°C . Use the $100 \mu\text{A}$ bias current setting to create a 1 V sensor signal. Other resistor values can be used depending on the sensor voltage you wish to simulate. To drive cooling current, set SET T to 1.35 V and to drive heating current, set SET T to 0.85 V .

NOTE: To stay within the Safe Operating Area, V_s must not exceed 5 V .

PIN DESCRIPTIONS

Table 1. Pin Descriptions and Wire Colors

PIN	NAME	CABLE COLOR	PIN DESCRIPTION
Connector J1, Cable WCB303 (included with LDT0520 and LDT1020)			
1	V_{DD_FL}	Green	Laser driver and laser diode power supply input; 3 to 12 VDC. Current rated to at least 1.1-times the laser diode forward current plus the driver quiescent current. Low-noise switching power supply recommended. Reference the Safe Operating Area calculator.
2	V_{DD_WTC}	Red	Temperature controller power supply input; 5 to 12 VDC. Current rated to at least 100 mA. Low-noise switching power supply recommended.
3	V_S	White	Power supply input for driving the TEC or resistive heater; 5 to 30 VDC. Current rated to at least 1.1-times the TEC maximum drive current. Low-noise switching power supply recommended. Reference the Safe Operating Area calculator.
4	GND	Black	Power supply ground. This is the only ground connection designed as a high current power supply return.
Connector J2, Cable WCB302 (included with LDT0520 and LDT1020)			
1	SP1	—	No connection
2	SP2	—	No connection
3	LD SHD	Red	Laser diode shutdown / interlock input. The onboard Enable switch must be set to ENABLE when this external enable function is used. TTL-compatible. Enable = Ground; Disable = OPEN or 3 to 5 V.
4	COM	Green/Blk	Low current return for monitors, inputs, and status pins. Do not use for high current return.
5	EXT LD SET	White	External laser diode setpoint input, optional. Range 0 to 2 V. Input impedance 5 k Ω . Transfer function shown in Table 2 . Set the LDREF switch to EXT (up) to reference the EXT LD SET input signal. The EXT LD SET voltage does not sum with the onboard trimpot setting.
6	COM	Green	Low current return for monitors, inputs, and status pins. Do not use for high current return.
7	LD P M	Orange/Blk	Photodiode current monitor output. The signal on this pin is proportional to the photodiode current. Voltage range 0 to 2 V. Transfer function shown in Table 2 .
8	LD I M	Blue	Laser current monitor output. The signal on this pin is proportional to the actual laser output current. Transfer function shown in Table 2 .
9	ACT T M	Red/Blk	Actual temperature sensor voltage monitor output. Output voltage equals the voltage drop across the temperature sensor. Voltage range 0 V to V_{DD_WTC} .
10	SET T M	White/Blk	Temperature setpoint voltage monitor output. Output voltage equals the temperature sensor setpoint voltage set by the onboard trimpot or the EXT T SET input.
11	EXT T SET	Orange	External temperature setpoint input, optional. Range 0.3 to ($V_{DD_WTC} - 2$). Input impedance > 1 M Ω . Transfer function shown in Table 2 . The EXT TEMP SET voltage does not sum with the onboard trimpot setting. Set the TREF switch to EXT (up) to reference the EXT T SET input signal. If the signal falls below 0.3 V the setpoint will default to 1 V. To reset the default safety circuit, the EXT T SET voltage must be > 0.4 V.
12	COM	Black	Low current return for monitors, inputs, and status pins. Do not use for high current return.

Continued ...

PIN DESCRIPTIONS (CONTINUED)

PIN	NAME	CABLE COLOR	PIN DESCRIPTION
Connector J3, Cable WCB301 (included with LDTC0520 and LDTC1020)			
1	LDC	Black	Laser diode cathode connection
2	PDA	White	Photodiode anode connection
3	PDC	Blue	Photodiode cathode connection
4	LDA	Red	Laser diode anode connection
5	COM	Green	Low current return for monitors, inputs, and status pins. Do not use for high current return.
6	TEC+	Red/Blk	Positive side of TEC. This pin supplies the current to the TEC (when using NTC sensors). Refer to the operating instructions for proper connections to a TEC or Resistive Heater based on the type of sensor being used.
7	TEC-	Orange	Negative side of TEC. This pin sinks the current from the TEC (when using NTC sensors).
8	SEN+	White/Blk	Positive side of temperature sensor. Bias current is driven from SEN+ to SEN-.
9	SEN-	Orange/Blk	Ground connection for the temperature sensor. Refer to the Specifications table for input voltage range. Do not use for high current return.
10	COM	Green/Blk	Low current return for monitors, inputs, and status pins. Do not use for high current return.

Table 2. Control and Monitor Transfer Functions

FUNCTION	LDTC0520	LDTC1020	DESCRIPTION
EXT LD SET, CC Mode	250 mA / V	500 mA / V	External setpoint input to control the laser drive current in Constant Current mode.
EXT LD SET, CP Mode	1 mA / V		External setpoint input to control the photodiode current in Constant Power mode.
LD P MON	500 μ A / V		The power monitor transfer function can be modified by changing a resistor on the circuit board. Contact the factory for details.
LD I MON	250 mA / V	500 mA / V	The laser current monitor indicates the current driven to the laser.
I_{LIM} (Internal Test Point)	250 mA / V	500 mA / V	Refer to page 20 for location of the I_{LIM} test point on the circuit board.
ACT T M	1 V / V		The ACT T M voltage matches the voltage drop across the temperature sensor.
SET T M	1 V / V		The SET T M voltage matches the setpoint voltage set by the onboard trimpot or the EXT T SET input (pin J2-11).
EXT T SET	1 V / V		The external temperature setpoint input.

Table 3. Wiring Diagram Reference and LIM Trimpot Functions

SENSOR TYPE	LOAD TYPE	V_{DD_WTC} AND V_s TIED	FIGURE, PAGE	LIM A TRIMPOT	LIM B TRIMPOT
NTC (Thermistor)	TEC	Either	Figure 11 on page 13	Cooling Current Limit	Heating Current Limit
	Heater*	Yes	Figure 17 on page 17	Set to OFF (fully CCW)	Heating Current Limit
		No	Figure 18 on page 17		
PTC (RTD, LM335, etc)	TEC	Either	Figure 19 on page 18	Heating Current Limit	Cooling Current Limit
	Heater*	Yes	Figure 20 on page 18	Heating Current Limit	Set to OFF (fully CCW)
		No	Figure 21 on page 18		

* Setting the LIM A and LIM B trimpots requires a special procedure when using a resistive heater.

ELECTRICAL SPECIFICATIONS

ABSOLUTE MAXIMUM RATINGS	SYMBOL	LDTC0520	LDTC1020	UNIT	NOTE
LD Supply Voltage	V_{DD_FL}	3 to 12		VDC	
TC Electronics Supply Voltage	V_{DD_WTC}	4.5 to 12		VDC	
TC Load Supply Voltage	V_S	4.5 to 30		VDC	
Max LD Output Current	I_{LD}	505	1010	mA	
Max TC Output Current	I_{TEC}	±2.2		A	
Laser Driver Internal Power Dissipation ¹	P_{LD_MAX}	2	4	W	$T_{AMBIENT} = 25^{\circ}C$ ¹
Temp Controller Internal Power Dissipation	P_{TC_MAX}	9		W	
Case Operating Temperature	T_{OPR}	-40 to 85		°C	
Case Storage Temperature	T_{STG}	-55 to 125		°C	
Weight		3.04	3.13	oz	86.2 g (LDTC0520) 88.7 g (LDTC1020)
Size		2.9 x 2.35 x 1.08		inches	73.6 x 59.7 x 27.3 mm

LASER DRIVER SPECIFICATIONS	SYMBOL	LDTC0520	LDTC1020	UNIT	NOTE
CONSTANT CURRENT CONTROL					
Short Term Stability, 1 hour		35 to 40		ppm	$T_{AMBIENT} = 25^{\circ}C$
Long Term Stability, 24 hours		50 to 75		ppm	$T_{AMBIENT} = 25^{\circ}C$
CONSTANT POWER CONTROL					
Short Term Stability, 1 hour		0.019		%	$T_{AMBIENT} = 25^{\circ}C$
Long Term Stability, 24 hours		0.011		%	$T_{AMBIENT} = 25^{\circ}C$
OUTPUT					
Peak Current	I_{MAX}	495 to 505	990 to 1010	mA	
Compliance Voltage		$V_{DD_FL} - (0.5 * V_{EXT_LD_SET})$		V	$I_{MAX} = 500$ mA
Rise Time		300		nsec	$I_{LD} = 500$ mA
Fall Time		300		nsec	$I_{LD} = 500$ mA
Bandwidth, Constant Current ²		500		kHz	Sinewave input signal
Delayed Start		100		msec	
Slow Start Ramp		15		mA / msec	
Depth of Modulation		99		%	100 kHz sinewave
POWER SUPPLY					
Power Supply Voltage	V_{DD_FL}	3 to 12		V	
Quiescent Current, V_{DD_FL}		2.2 to 4.6	4.4 to 9.2	mA	
EXT LD SET INPUT					
Input Impedance		5		kΩ	
Input Voltage Range	$V_{EXT_LD_SET}$	0 to 2		V	
Damage Threshold		$-0.3 > V_{EXT_LD_SET} > V_{DD_FL} + 0.3$		V	
NOISE					
Noise and Ripple (RMS)		7.5	22	μA RMS	$I_{LD} = 100$ mA; 100 kHz bandwidth
Leakage Current		1 0.2 0.3		mA	$V_{EXT_LD_SET} = 0$ V, Output = ON $V_{EXT_LD_SET} = 0$ V, Output = OFF $V_{EXT_LD_SET} = 2$ V, Output = OFF

- Derate laser driver internal power dissipation by 34 mW / °C when operating above 25°C. For the LDTC1020 with dual FL500 chips, derating should be applied to both chips for a total of 68 mW / °C.
- Modulation bandwidth in Constant Power mode is dependent on photodiode bandwidth, and is typically lower than the bandwidth in Constant Current mode because of the frequency response of the photodiode.

ELECTRICAL SPECIFICATIONS (CONTINUED)

TEMPERATURE CONTROLLER SPECIFICATIONS	MIN	TYP	MAX	UNIT	NOTE
OUTPUT CURRENT					
Max Output Current	±2.0		±2.2	A	
Compliance Voltage, TEC	$V_S - 0.7$	$V_S - 0.5$		V	Full Temp Range, $I_{TEC} = 100$ mA
Compliance Voltage, TEC	$V_S - 1.2$	$V_S - 1.0$		V	Full Temp Range, $I_{TEC} = 1$ A
Compliance Voltage, TEC	$V_S - 1.6$	$V_S - 1.4$		V	Full Temp Range, $I_{TEC} = 1.5$ A
Compliance Voltage, TEC	$V_S - 1.8$	$V_S - 1.6$		V	Full Temp Range, $I_{TEC} = 2$ A
Compliance Voltage, Resistive Heater	$V_S - 1.7$	$V_S - 1.6$		V	Full Temp Range, $I_{TEC} = 2$ A
Short Term Stability, 1 hour ¹	0.001	0.002	0.010	°C	OFF ambient, 10 kΩ thermistor @ 25°C
Short Term Stability, 1 hour ¹		0.005		°C	ON ambient, 10 kΩ thermistor @ 25°C
Long Term Stability, 24 hours ¹	0.003	0.008	0.010	°C	OFF ambient, 10 kΩ thermistor @ 25°C
Quiescent Current, V_S	20	50	100	mA	
POWER SUPPLY					
Power Supply Voltage, V_{DD_WTC}	4.5		12	VDC	
Quiescent Current, V_{DD_WTC}		55	105	mA	
Power Supply Voltage, V_S	4.5		30	VDC	
TEMPERATURE SENSORS					
Sensor Compatibility	Thermistor, RTD, IC Sensors				
Sensor Input Voltage Range ²	0.25 to ($V_{DD_WTC} - 2.0$)			V	
Sensor Input Damage Threshold	3.6			V	
Sensor Bias Current Selection	Adjustable, 2 μA to 1 mA				
EXTERNAL SETPOINT AND MONITORS					
EXT T SET Input Impedance		1		MΩ	
EXT T SET Input Voltage Range		0 to 3.3		V	
EXT T SET Input Damage Threshold		0 to 3.6		V	
Setpoint vs. Actual Temperature Accuracy	0.1	2	4	mV	$T_{SET} = 25^\circ\text{C}$, 10 kΩ thermistor
FEEDBACK LOOP					
P (Proportional Gain)	18	20	22	A / V	
I (Integrator Time Constant)	2	3	4.5	sec	

¹. When using resistive heaters, stability can only be consistently achieved when specified temperatures are 10°C or more above ambient.

². The sensor bias source has a compliance up to ($V_{DD_WTC} - 2.0$ V). In normal operation this limits the sensor voltage range to (0.25 V to $V_{DD_WTC} - 2.0$ V). While voltages up to ±0.5 V outside this range on the EXT T SET pin will not damage the unit, the controller will not provide proper control under these conditions.

NOTE: Operation at $V_S > 5$ V or $V_{DD_FL} > 5$ V requires evaluation of the SOA curves and current limit settings. Damage to the LDTC will occur if it is operated outside the Safe Operating Area (SOA). See our online SOA calculator for:

WTC3243 at <http://www.teamwavelength.com/support/calculator/soa/soatc.php>

FL500 at <http://www.teamwavelength.com/support/calculator/soa/soald.php>.

SAFETY INFORMATION & THERMAL DESIGN CONSIDERATIONS

SAFE OPERATING AREA – DO NOT EXCEED INTERNAL POWER DISSIPATION LIMITS

Before attempting to operate the LDTC, it is imperative that you first determine that the laser driver and temperature controller will operate within the *Safe Operating Area* (SOA). Operating the unit outside of the SOA may damage the controller or the load, and will void the warranty.

Go to the Wavelength Electronics website for the most accurate, up-to-date, and easy to use SOA calculators:

Laser Diode Drivers:

<http://www.teamwavelength.com/support/calculator/soa/soald.php>

Temperature Controllers:

<http://www.teamwavelength.com/support/calculator/soa/soatc.php>

SOA charts are included in this datasheet for quick reference (page 22), but we recommend you use the online tools instead.



TO ENSURE SAFE OPERATION OF THE LDTC CONTROLLER, IT IS IMPERATIVE THAT YOU DETERMINE IF THE UNIT IS GOING TO BE OPERATING WITHIN THE INTERNAL HEAT DISSIPATION SAFE OPERATING AREA (SOA).

For more information on Safe Operating Area, see our Application Note [AN-LDTC01: The Principle of the Safe Operating Area](#).

When you assemble and mount the TEC (or heater), heatsink, and temperature sensor, make sure the physical connections between the components are solid. We recommend using thermal paste or thermal washers at the load/TEC and TEC/heatsink interfaces. The thermistor must be in firm contact with the load in order to achieve stable and reliable temperature control.

PREVENT DAMAGE FROM ELECTROSTATIC DISCHARGE

Before proceeding, it is critical that you take precautions to prevent electrostatic discharge (ESD) damage to the driver and your laser. ESD damage can result from improper handling of sensitive electronics, and is easily preventable with simple precautions.

Enter the search phrase “*ESD Precautions for Handling Electronics*” in an internet search engine to find information on ESD-safe handling practices.

We recommend that you always observe ESD precautions when handling the LDTC controller and loads.

THEORY OF OPERATION

The LDTC Laser Diode Driver and Temperature Controller combines Wavelength's proprietary FL500 and highly stable WTC3243 in one compact module.

The LDTC0520 employs a single FL500 laser diode control chip; the LDTC1020 parallels two FL500 chips. The current source continually monitors the actual output current, compares it to the setpoint, and adjusts the current if there is a difference between the two signals.

It may be useful to remember that you do not directly set the drive current setpoint; instead, you adjust a voltage signal that represents the output current. The setpoint voltage is controlled by the onboard trimpot or by an external input.

As current is driven through the load, there is a voltage drop across the load because of the impedance. As the current increases, the voltage drop may increase to the point that it reaches the Compliance Voltage limit of the current source. Once that occurs the current source is no longer able to increase the current driven to the load even if you increase the setpoint.

The LDTC laser driver includes features that help protect your laser and make the driver more versatile in a wide array of applications:

- The current limit is set by an onboard trimpot and protects the laser from over-current conditions. The current limit circuit is designed to avoid overshoot, ringing, or saturating the control elements, and recovers from limit events without phase shifts or inversions.
- Slow-start delays the current ramp by 100 msec, and then ramps the current to setpoint at a rate of 15 mA / msec.
- The photodiode feedback control loop allows for Constant Power operation whereby the driver adjusts the laser forward current in order to maintain a constant photodiode current.
- Brownout protection switches off the laser diode drive current if V_{DD_FL} drops below 2.7 VDC.

The WTC3243 delivers bidirectional current to a Peltier Effect thermoelectric cooler, or unidirectional current to a resistive heater. The controller adjusts the output current in order to change the temperature of the sensor that is connected to the thermal load. The goal is to make the voltage across the sensor match the setpoint voltage, and then keep them equal in spite of changes to ambient conditions and variations in thermal load.

The controller measures the load temperature by driving a current through the temperature sensor and measuring the voltage drop across it. Similarly to the laser driver, you do not directly adjust the setpoint on the temperature controller; rather, you adjust a voltage signal that represents the sensor voltage at the desired temperature setpoint. The controller continuously compares the setpoint voltage and the actual sensor voltage. If there is a difference between the two signals the controller adjusts the output current—thereby driving the TEC or heater to change temperature—until the difference is zero.

Once the actual sensor voltage equals the setpoint voltage, the controller makes minor adjustments to the output current in order to keep the difference at zero.

The controller includes features that help protect the load from damage, and also make it more versatile in a wide array of applications.

- Independent heating and cooling current limits to protect from thermal runaway situations.
- The temperature setpoint can be adjusted with the onboard trimpot or by an external voltage signal.
- Control loop: the controller employs a smart Proportional-Integrating control loop to adjust the drive current. The proportional term is user-adjustable, and when properly configured will quickly settle the load to temperature with minimal overshoot and ringing.

OPERATING INSTRUCTIONS -- TEMPERATURE CONTROLLER

These instructions are written for the most common application of the LDTCxx20 Controllers: driving a laser diode, and controlling a Peltier-type thermoelectric cooler with a 10 k Ω thermistor sensor. We recommend you read and completely understand these instructions before proceeding with wiring the controller. Information for other configurations is also included in the technical support section on **page 17**.

Wavelength recommends configuring the temperature controller before configuring the laser diode driver. Additionally, we recommend using test loads to simulate the thermistor, TEC or heater, laser diode, and photodiode. Schematics for test loads are presented in **Figure 6** and **Figure 7 on page 4**.

These instructions detail the steps necessary to configure the current limits for the temperature controller using a test load. Once that is done, the controller is reconfigured with the thermal load and sensor for your application. Then the laser driver is configured with a test load. Finally, the laser diode is connected and the LDTCxx20 is ready to enter regular service.



MAKE CERTAIN THE OUTPUT LEADS ARE NOT SHORTED. IF THE LASER OUTPUT OR TEMPERATURE CONTROLLER OUTPUT LEADS ARE SHORTED DURING SETUP, CURRENT WILL FLOW AND THE LDTC MAY BE DAMAGED.

Wavelength recommends that initial wiring and configuration of the LDTCxx20 is performed with test loads in place of the TEC and thermistor. Using test loads reduces the risk of damaging expensive components, and can make the configuration process simpler.

The configuration sequence is as follows:

- Connect the power supplies and test loads
- Set the current limit
- Replace the test loads with your temperature sensor and TEC
- Configure for external or local (internal) control
- Adjust the temperature setpoint and monitor the controller

NECESSARY EQUIPMENT

The following equipment is the minimum necessary to configure the LDT0 for basic operation.

- LDT0 controller
- Power supplies; choose low-noise power supplies for the best performance and refer to **page 11** for details on each power supply requirement.
- V_{DD_FL} – power supply for the laser driver electronics and the laser diode
- V_{DD_WTC} – power supply for the temperature controller electronics
- V_S – power supply to drive the TEC
- Digital multimeter, 4-½ digit resolution recommended
- Laser diode
- Thermistor or other temperature sensor
- Peltier-type thermoelectric module, or resistive heater, heatsink for the temperature-controlled load, mounting hardware, thermal washers or paste
- Connecting wires

ONBOARD ADJUSTMENTS AND CONTROLS

Figure 8 shows the onboard adjustments and controls that are accessible with the cover on.

DIP Switch Functions

LDREF = Internal vs. External Laser Diode Setpoint
 CC | CP = Constant Current vs. Constant Power Control Mode
 TREF = Internal vs. External Temperature Setpoint



* DO NOT CHANGE SWITCH POSITIONS WHILE THE OUTPUT IS ENABLED; DOING SO MAY DAMAGE THE LOAD.

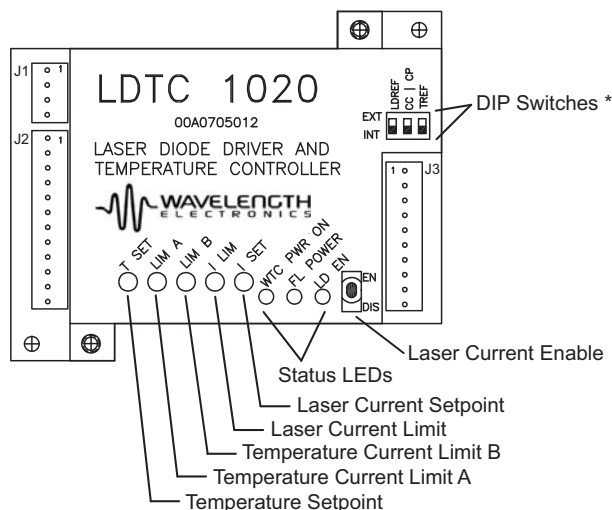

Figure 8. LDT0 Top View

POWER SUPPLY REQUIREMENTS

The power supplies can be configured in a number of different ways in order to integrate the LDT0 more smoothly into your application. The instructions provided in the Configuration sections are for separate power supplies.

If the laser anode is connected to the laser diode case, special precautions must be followed when configuring the power supply. Refer to **page 21** for more detailed information.

Likewise, if the thermistor or TE module are case-common with the laser diode, the LD and temperature controller power supplies may need to be isolated from each other, or a bipolar supply may be required. Refer to **page 21**.

- Separate V_{DD_WTC} , V_S , and V_{DD_FL}
 - V_{DD_WTC} must be rated to at least 100 mA
 - V_S must be rated for at least 1.1-times the current of the temperature controller load
 - V_{DD_FL} must be rated for 1.1-times the laser current plus 10 mA for the laser driver electronics
- Tied V_{DD_WTC} and V_S , separate V_{DD_FL}
 - The temperature controller power supply must be rated for at least 1.1-times the maximum TEC or heater current, plus 100 mA for the TEC control electronics
 - V_{DD_FL} must be rated for 1.1-times the laser current plus 10 mA for the laser driver electronics
 - Refer to **page 21** for important information if the power supply inputs will be tied
- All three power supply inputs tied together and driven from a single supply.
 - The power supply must be rated for at least 1.1-times the maximum TEC or heater current, plus 1.1-times the maximum laser diode current, plus 100 mA for the TEC control electronics, plus 10 mA for the laser driver electronics
 - Refer to **page 21** for important information if the power supply inputs will be tied

Wavelength recommends using the best quality power supplies available. Noise on the power supply inputs will affect the overall system noise performance, particularly on the laser driver.

WIRE THE TEMPERATURE CONTROLLER POWER SUPPLIES AND TEST LOADS

Reference **Figure 9** and wire the temperature controller power supplies. Also connect the digital multimeter to the monitor pins, as shown.

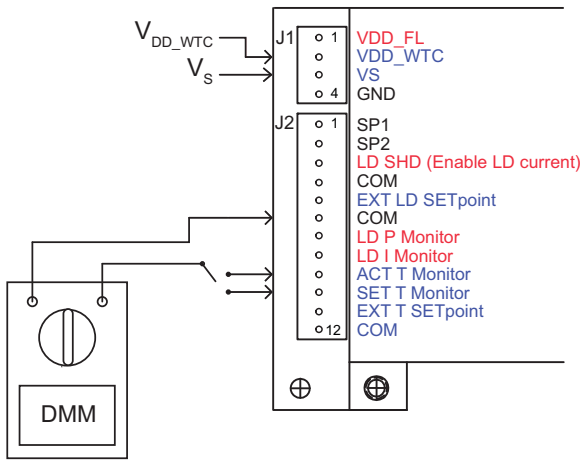

Figure 9. Temperature Controller Power Supply and Monitor Wiring

Next wire the temperature controller test loads, referencing **Figure 10** for details. With the test loads, to stay within the Safe Operating Area, V_S must not exceed 5 V.

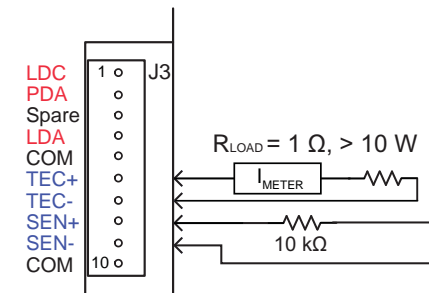

Figure 10. Temperature Controller Test Load Wiring



OPERATING THE LDT C WITHOUT A TEMPERATURE SENSOR WILL DRIVE MAXIMUM CURRENT THROUGH THE TEC OR HEATER, POTENTIALLY DAMAGING IT.

SET THE TEMPERATURE CONTROLLER CURRENT LIMITS

These instructions are for a TEC application; if you are using a resistive heater refer to **page 17** for instructions.

Refer to the datasheet for your TEC to determine the maximum allowable drive current (I_{LIM}). Measure the exact resistance of the test load (R_{LOAD}), then calculate the V_{LIM} voltage drop:

Equation 1. $V_{LIM} = I_{LIM} * R_{LOAD}$

Adjust the simulated thermistor to a total resistance value of 10 kΩ Ohm to simulate room temperature.

Switch on the V_{DD_WTC} and V_S power supplies; the WTC POWER ON LED will illuminate green. As soon as power is applied the temperature controller is active and will drive current through R_{LOAD} .



THE TEMPERATURE CONTROLLER OUTPUT IS ENABLED AS SOON AS POWER IS SUPPLIED TO V_{DD_WTC} AND V_S . THE WTC PWR ON LED ILLUMINATES GREEN WHEN POWER IS ON TO THE TEMPERATURE CONTROLLER.

Next adjust the T SET trimpot fully counter-clockwise to simulate a “high temperature” setpoint; this will cause the controller to drive current through R_{LOAD} in the direction that would cause a TEC to heat. Adjust the LIM B trimpot until the voltage displayed on the voltmeter matches the V_{LIM} value calculated above.

Adjust the T SET trimpot fully clockwise to simulate a “low temperature” setpoint. This will cause the temperature controller to drive current through R_{LOAD} in the direction that would cause a TEC to cool. Adjust the LIM A trimpot until the voltage matches V_{LIM} .

Finally, adjust the T SET trimpot until the voltage across R_{LOAD} is zero. This step ensures that when the TEC and thermistor are connected the temperature setpoint will be approximately 25°C, and the controller will not drive high current through the TEC.

Switch off the power supplies.

WIRE THE LDT FOR YOUR TEMPERATURE CONTROL APPLICATION

Remove the test loads, and reconfigure the temperature controller with your temperature sensor and load. Refer to **Table 4** to find the proper wiring diagram for your configuration.

If the sensor is not a 10 kΩ thermistor then you must make internal modifications to the LDT; refer to **page 18**.

Table 4. Wiring Diagram Reference

SENSOR TYPE	LOAD TYPE	V _{DD,WTC} AND V _S TIED	SEE FIGURE
NTC (10 kΩ Thermistor)	TEC	Either	Figure 9
	Heater*	Yes	Figure 17
No		Figure 18	
PTC (RTD, LM335, etc)	TEC	Either	Figure 19
	Heater*	Yes	Figure 20
		No	Figure 21

* Note that setting the LIM A and LIM B trimpots requires a different procedure when using a resistive heater.

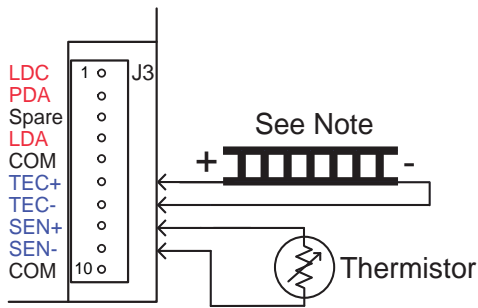

Note: Current flows from TEC+ to TEC-. Connect the TEC+ lead to pin J3-6 and the TEC- lead to pin J3-7. Keep the wires as short as possible to reduce lead voltage drop at high current.

Figure 11. NTC sensor and TEC Wiring

CONFIGURE ONBOARD OR EXTERNAL SETPOINT CONTROL

The temperature setpoint can be controlled with an onboard trimpot, or by external signal input to pin J2-11.

Select the temperature setpoint reference by setting the TREF switch; refer to **Figure 12**. To use the onboard trimpot for temperature setpoint control, set the TREF switch to INT (down). To reference the EXT T SET input, set the TREF switch to EXT (up).

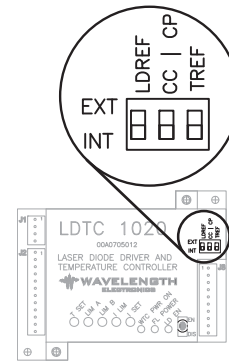

Figure 12. Configuration DIP Switches

ADJUST THE TEMPERATURE SETPOINT

If the LDT is configured for onboard temperature control, the setpoint is adjusted using the T SET trimpot, accessible through the hole in the cover. The temperature setpoint corresponds directly to the desired voltage drop across the temperature sensor.

If the LDT is configured for external setpoint control, connect the signal source to pin J2-11. Example setpoint circuits are shown on **page 20**, and the transfer function for the EXT T SET input is shown in **Table 2**.

If the external temperature setpoint signal falls below 0.3 V, the failsafe circuit in the controller will reset the temperature setpoint to 1 V, corresponding to 25°C when using a 10 kΩ thermistor. To reset the failsafe circuit, the external setpoint voltage must be set to > 0.4 V. The default safety temperature can be changed at the factory; contact Sales for more information.

MONITOR SENSOR VOLTAGE AND SETPOINT VOLTAGE

Connector J2 includes outputs for monitoring actual temperature sensor voltage and temperature setpoint voltage. The specifications for the pins are indicated on **page 5**, and the transfer functions listed in **Table 2** on **page 6**.

CONTROL LOOP TUNING

The PI loop parameters are configured at the factory, and designed to work for a wide range of loads and applications. The factory defaults are:

$$R_p = R_5 = 24.9 \text{ k}\Omega \quad [P_{\text{GAIN}} = 20 \text{ A/V}]$$

$$R_i = R_6 = 31.6 \text{ k}\Omega \quad [I_{\text{TIME-CONSTANT}} = 2.2 \text{ seconds}]$$

Table 5 lists the suggested resistor values for R_p versus sensor type and the ability of the thermal load to change temperature rapidly.

Table 5. Proportional Gain Resistor R_p vs. Sensor Type and Thermal Load Speed

PROPORTIONAL GAIN RESISTOR R_p	PROPORTIONAL GAIN (A / V)	SENSOR TYPE / THERMAL LOAD SPEED
4.99 kΩ	5	Thermistor / Fast
24.9 kΩ	20	Thermistor / Slow
100 kΩ	50	RTD / Fast
Open	100	RTD / Slow
24.9 kΩ	20	AD590 or LM335 / Fast
100 kΩ	50	AD590 or LM335 / Slow

Use **Equation 2** to calculate R_p from P_{GAIN} .

Equation 2. Calculating R_p from P_{GAIN}

$$R5 = R_p = \left(\frac{100,000}{PGAIN - 1} \right) [\Omega]$$

To calculate P_{GAIN} from R_p use **Equation 3**.

Equation 3. Calculating P_{GAIN} from R_p

$$PGAIN = \left(\frac{100}{\frac{100,000}{R_p} + 1} \right) [A / V]$$

To locate R_i and R_p on Rev C only, refer to **Figure 13**.

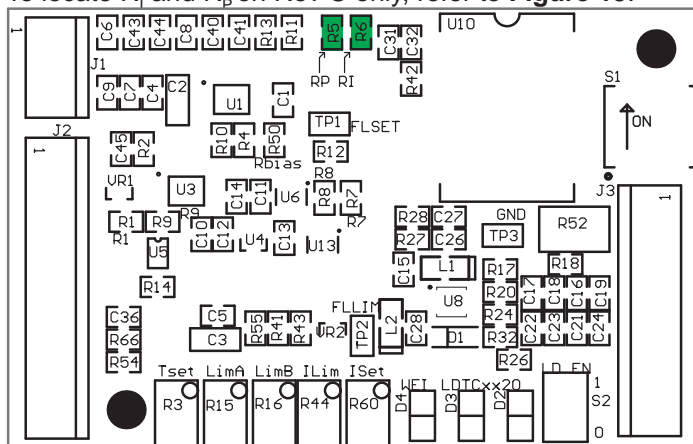

Figure 13. R_p and R_i Component Locator (Topside of Board) Product Rev C only

Table 6 lists the suggested resistor values for R_i versus sensor type and the ability of the thermal load to change temperature rapidly.

Table 6. Integrator Time Constant vs. Sensor Type and Thermal Load Speed

INTEGRATOR RESISTOR R_i	INTEGRATOR TIME CONSTANT (SECONDS)	SENSOR TYPE / THERMAL LOAD SPEED
21.4 kΩ	3	Thermistor / Fast
13.3 kΩ	4.5	Thermistor / Slow
Open	0.53	RTD / Fast
112 kΩ	1	RTD / Slow
112 kΩ	1	AD590 or LM335 / Fast
13.3 kΩ	4.5	AD590 or LM335 / Slow

Equation 4 demonstrates how to calculate a value for R_i given a desired integrator time constant. The Integrator Time Constant, I_{TC} , is measured in seconds.

Equation 4. Calculating R_i from I_{TC}

$$R6 = R_i = \left(\frac{100,000}{(1.89) I_{TC} - 1} \right) [\Omega]$$

Equation 5 demonstrates how to calculate the I_{TC} , given a value for R_i .

Equation 5. Calculating I_{TC} from R_i

$$I_{TC} = (0.53) \left(\frac{100,000}{R_i} + 1 \right) [\text{Seconds}]$$

To locate R_i and R_p on Rev A & B only, refer to **Figure 14**.

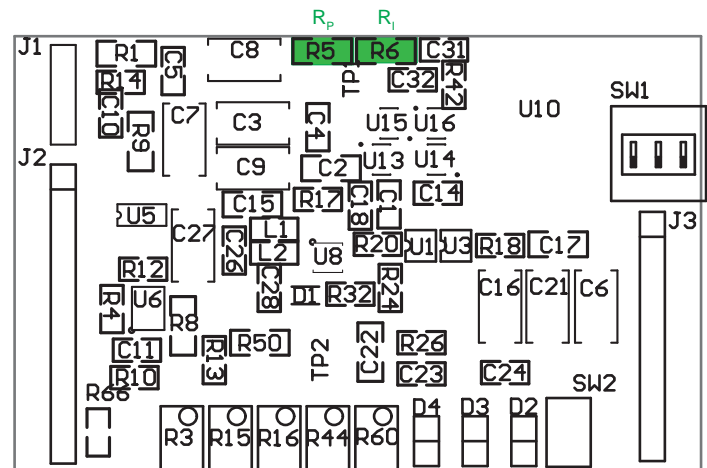

Figure 14. R_p and R_i Component Locator (Topside of Board) Product Rev A & B only

OPERATING INSTRUCTIONS -- LASER DRIVER

Wavelength recommends that initial wiring and configuration of the LDTCx20 is performed with test loads in place of the laser. Using test loads reduces the risk of damaging expensive components, and can make the configuration process simpler.

The configuration sequence is as follows:

- Connect the power supply and test load
- Set the current drive limit
- Replace the test load with your laser diode
- Adjust the laser drive setpoint
- Configure for external or local (internal) control
- Adjust the current setpoint and monitor the driver

WIRE THE LASER DRIVER POWER SUPPLY AND TEST LOAD

The current limit is set with the driver in Constant Current mode and can be set in two ways; the method described here is done with the cover on the LDTC but requires the output current be enabled. An alternate method is presented on [page 20](#).

Leave in place all the components that were connected during the temperature controller configuration, and now wire the laser driver power supply per [Figure 15](#).

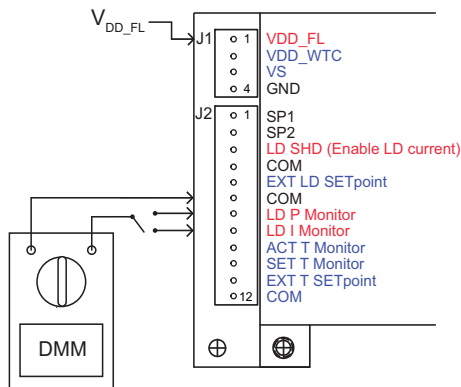

Figure 15. Laser Driver Power Supply and Monitor Wiring

Next wire the laser driver test load; refer to [Figure 16](#). With the test loads, to stay within the Safe Operating Area, V_s must not exceed 5 V.

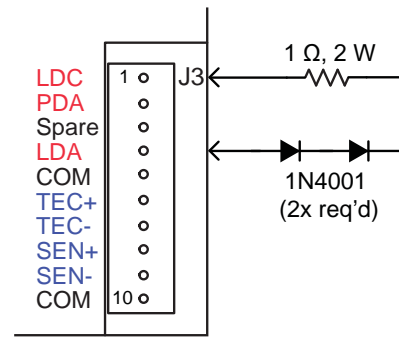

Figure 16. Laser Driver Test Load Wiring

SET THE LASER DRIVER CURRENT LIMIT

Refer to the datasheet for your laser diode to determine the maximum allowable drive current (I_{LIM}). Measure the exact resistance of the test load (R_{LOAD}), then calculate the V_{LIM} voltage drop across the test load resistor:

Equation 6.
$$V_{LIM} = I_{LIM} * R_{LOAD}$$

Set the I SET trimpot to zero by turning fully counter-clockwise at least 12 turns; set the I LIM trimpot to full-scale by turning it clockwise at least 12 turns. Set the CC | CP switch to CC.

Switch on the V_{DD_FL} power supply; the FL POWER LED will illuminate green. Set the onboard laser output switch to EN to enable the current; the LD EN LED will illuminate green.

Adjust the I SET trimpot clockwise until the voltage on the LD I Monitor pins (pin J2-8 to J2-6) matches the V_{LIM} value calculated above. Now adjust the I LIM trimpot down by turning counter-clockwise until the voltage on the voltmeter starts to change. Now the limit is set at the maximum desired operating current.

Measure the voltage on the LD I MON pin; it should correspond to the desired limit current value. Refer to [Table 2](#) for the LD I MON transfer function for your LDTC model, and verify that the drive current is correct using this equation:

Equation 7.
$$I_{LD} = V_{LD_MON} * \text{Transfer Function}$$

Adjust the I SET trimpot counter-clockwise to zero the setpoint current. Set the enable switch to DIS to disable the output current, and switch off the V_{DD_FL} power supply. Remove the test load.

To practice using the driver in Constant Power mode, refer to [page 3](#) for the Constant Power test circuit.

WIRE THE LDTC FOR YOUR LASER DRIVER APPLICATION

If you are comfortable with the operation of the LDTC laser driver, connect your laser diode per **Figure 2 on page 2**. This figure also shows how to connect the optional external enable switch and external setpoint signal source. Example setpoint circuits are shown on **page 20**. The transfer function for the EXT LD SET input is shown in **Table 2**.



DO NOT INSERT OR REMOVE THE LASER DIODE FROM THE CIRCUIT WHILE POWER IS APPLIED TO THE LDTC. THE LASER DIODE MAY BE DAMAGED OR DESTROYED.

SET CONSTANT POWER OR CONSTANT CURRENT CONTROL MODE

Refer to **Figure 12**, and set the mode switch for Constant Current or Constant Power mode: the mode switch is the center DIP switch, labeled “CC | CP”. For Constant Current mode operation, set the switch to INT (down); for Constant Power mode, set the switch to EXT (up).



DO NOT ADJUST THE CC | CP SWITCH WHILE THE OUTPUT IS ENABLED AND DRIVING A LASER DIODE. THE LASER DIODE MAY BE DAMAGED OR DESTROYED.

In CC mode, the setpoint voltage correlates directly to the laser diode current. In CP mode the setpoint correlates to the photodiode feedback current. See **Table 2 on page 6** for the transfer functions for CC and CP mode.

SET THE DRIVER FOR ONBOARD OR EXTERNAL SETPOINT CONTROL

Next, set the reference source for the laser current setpoint.

To use the onboard trimpot to control the laser current setpoint (Constant Current mode) or the laser power (Constant Power mode),

1. Set the LDREF DIP switch to INT (down).
2. Ensure that LD SHD (pin J2-3) is tied to ground.

To use an external setpoint signal,

1. Set the LDREF DIP switch to EXT (up).
2. Connect the signal source to EXT LD Setpoint (pin J2-5).
3. Ensure that the LD SHD (pin J2-3) is tied to ground.



DO NOT ADJUST THE LDREF SWITCH WHILE THE OUTPUT IS ENABLED AND DRIVING A LASER DIODE. THE LASER DIODE MAY BE DAMAGED OR DESTROYED.

The laser output enable can be controlled from the onboard switch, or by an external signal. If the external switch is used, the onboard switch must be set to EN (enabled).

Both the external enable signal and the onboard enable switch must be set to ENABLE for the LDTC to drive current to the laser.

ADJUST THE LASER OUTPUT SETPOINT

If the LDTC is configured for onboard laser control, the setpoint is adjusted using the I SET trimpot, accessible through the hole in the front cover.

If the LDTC is configured for external setpoint control, connect the signal source to pin J2-5. Example setpoint circuits are shown on **page 20**, and the transfer function for the EXT LD SET input is shown in **Table 2**.

MONITOR LASER DIODE AND PHOTODIODE CURRENT

Connector J2 includes monitors for laser forward current and photodiode current. Pin J2-8 is LD I Mon and pin J2-7 is LD P Mon.

The LD I Mon pin outputs a voltage proportional to the laser diode forward current according to the transfer functions listed in **Table 2**.

Both monitor signals are available at all times, regardless of whether the driver is operating in CC or CP mode.

The LD P Mon pin outputs a voltage proportional to the photodiode current; refer to **Table 2** for the transfer function. The standard maximum photodiode current is 2 mA. The photodiode current range can be changed by replacing a 1206-sized surface-mount resistor on the circuit board; contact the factory for assistance.

ADDITIONAL TECHNICAL INFORMATION

This section includes useful technical information on these topics:

- Set the Current Limit When Using Resistive Heaters
- Wire the LDTC Temperature Controller, Alternate Applications
- Set the Sensor Bias Current Resistor
- Use The LM335
- Use The AD590
- Adjust Sensor Gain
- External Setpoint Circuits
- An Alternate Method for Setting the Laser Driver Current Limit
- **Safely Tie the Power Supply Inputs**
- Safe Operating Area Calculation

SET THE CURRENT LIMIT WHEN USING RESISTIVE HEATERS

The instructions on **page 12** do not apply when a resistive heater is used. Follow the instructions provided here instead.

First, set up the controller per **page 13**. Then follow these steps:

- Calculate the voltage drop across the load resistor at the limit current: $V_{LIM} = I_{LIM} * R_{LOAD}$
- Adjust the “thermistor” test load to 10 kΩ resistance
- Place the multimeter leads across the test load resistor
- Switch on the power supplies
- Adjust T SET fully counter-clockwise to simulate a high temperature setpoint
- If you are using an NTC sensor:
 - If V_{DD_WTC} and V_S are tied, the LIM A trimpot must be set to zero (fully counterclockwise at least 12 turns). This trimpot is irrelevant if V_{DD_WTC} and V_S are separated.
 - Adjust the LIM B trimpot until the voltage measured across R_{LOAD} matches V_{LIM} calculated above.
- If you are using a PTC sensor:
 - If V_{DD_WTC} and V_S are tied, the LIM B trimpot must be set to zero (fully counterclockwise at least 12 turns). This trimpot is irrelevant if V_{DD_WTC} and V_S are separated.
 - Adjust the LIM A trimpot until the voltage measured across R_{LOAD} matches V_{LIM} calculated above
- Now adjust the T SET trimpot until the voltage across R_{LOAD} is close to zero. This step helps ensure the controller will not drive high current once the resistive heater is attached.
- Switch off the power supplies, disconnect the test loads, and rewire the LDTC for your application.

WIRE THE LDTC TEMPERATURE CONTROLLER, ALTERNATE APPLICATIONS

The LDTC can be wired in a number of different configurations using different temperature sensors and load transducers. **Table 7** identifies which wiring diagram to use for each case.

If the sensor is not a 10 kΩ thermistor then you must make internal modifications to the LDTC. Refer to **page 18** and **page 19** for instructions on changing the internal gain resistor and sensor bias resistor.

Table 7. Wiring Diagram Reference and LIM Trimpot Functions

SENSOR TYPE	LOAD TYPE	V_{DD_WTC} AND V_S TIED	SEE FIGURE
NTC (Thermistor)	TEC	Either	Figure 11
	Heater*	Yes	Figure 13
		No	Figure 14
PTC (RTD, LM335, etc)	TEC	Either	Figure 19
	Heater*	Yes	Figure 20
		No	Figure 21

* Note that setting the LIM A and LIM B trimpots requires a different procedure when using a resistive heater.

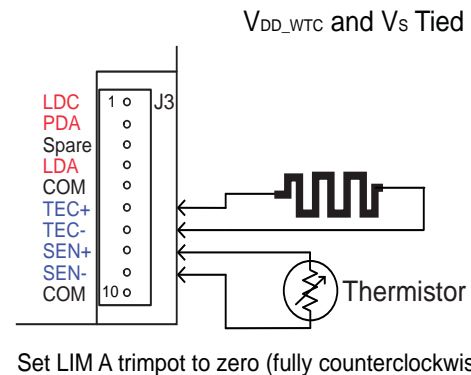

Figure 17. Wiring for NTC Sensor and Resistive Heater, V_{DD_WTC} and V_S Tied

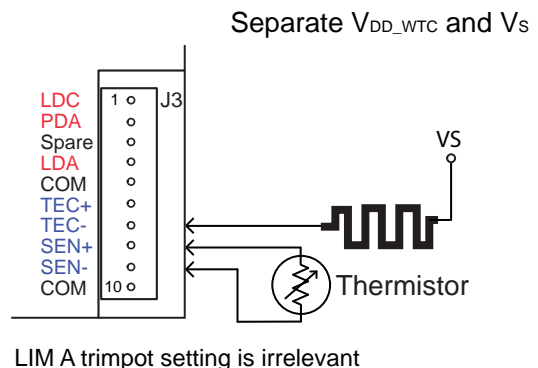
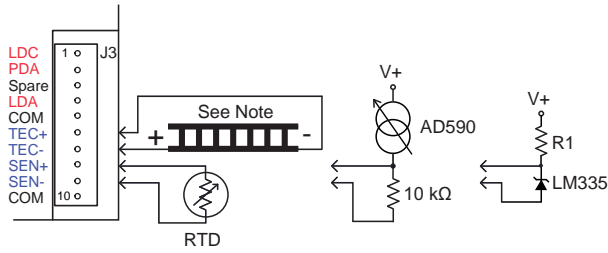

Figure 18. Wiring for NTC Sensor and Resistive Heater, V_{DD_WTC} and V_S Separate



Note: Current flows from TEC- to TEC+. Connect the TEC+ lead to pin J3-7 and the TEC- lead to pin J3-6. Keep the wires as short as possible to reduce lead voltage drop at high current.

Refer to AD590 and LM335 datasheets for instructions on using those sensors.

Figure 19. Wiring for PTC Sensor and TEC

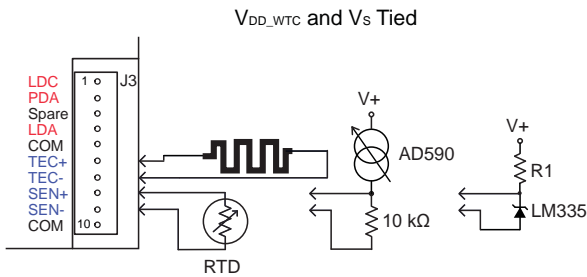

Set LIM B trimpot to zero (fully counterclockwise)

Refer to AD590 and LM335 datasheets for instructions on using those sensors.

Figure 20. Wiring for PTC Sensor with Resistive Heater, V_{DD_WTC} and V_S Tied

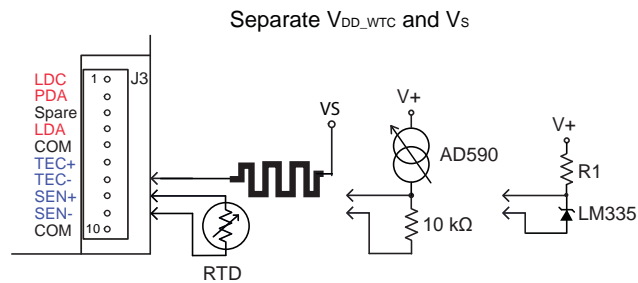

LIM B trimpot setting is irrelevant

Refer to AD590 and LM335 datasheets for instructions on using those sensors.

Figure 21. Wiring for PTC Sensor and Resistive Heater, V_{DD_WTC} and V_S Separated

SENSORS OTHER THAN A 10 KΩ THERMISTOR

The LDTCOxx20 is factory-configured to bias a 10 kΩ thermistor with 100 μA current, but with simple modifications other sensors can be used. The instructions for making the changes are included here, and are recommended for users with experience soldering surface mounted components. These modifications can be made at the factory, as well.

SET THE SENSOR BIAS CURRENT RESISTOR

To change the sensor bias current, the 1206-sized surface mount R_{BIAS} resistor must be replaced. Table 8 indicates the proper R_{BIAS} and R_S values, and Figure 22 shows the location of the R_{BIAS} resistor and R_S pins.

The I_{BIAS} current can be adjusted to other values based on the value of R_{BIAS} , according to the relation:

$$\text{Equation 8. } R_{BIAS} = 2 / I_{BIAS} \quad (\Omega)$$

The 100 Ω sensor gain resistor (R_S) may need to be added to two pins that protrude from the top of the circuit board (read the Adjust Sensor Gain section below).

Table 8. R_{BIAS} and R_S Values for Alternate Temperature Sensors

SENSOR TYPE	R_{BIAS} VALUE	SENSOR BIAS CURRENT	R_S VALUE	GAIN
2.25 kΩ Thermistor	2 kΩ	1 mA	Open	1
5 kΩ Thermistor	10 kΩ	200 μA	Open	1
10 kΩ Thermistor Default	20 kΩ	100 μA	Open	1
20 kΩ Thermistor	40 kΩ	50 μA	Open	1
50 kΩ Thermistor	100 kΩ	20 μA	Open	1
100 kΩ Thermistor	200 kΩ	10 μA	Open	1
500 kΩ Thermistor	1 MΩ	2 μA	Open	1
100 Ω Pt RTD	2 kΩ	1 mA	100 Ω	10
1 kΩ Pt RTD	2 kΩ	1 mA	Open	1
LM335	2 kΩ	1 mA	Open	1
AD590	Open	–	Open	1

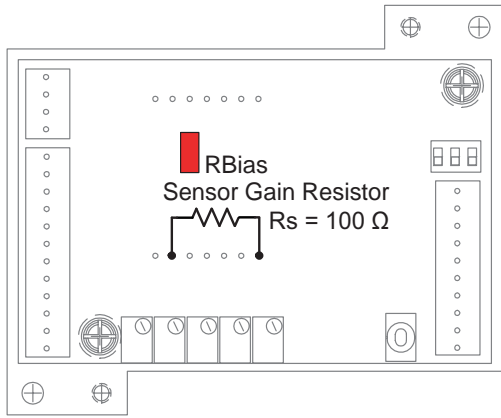

Figure 22. Sensor Gain Resistor and Location of R_{BIAS} — Rev C only

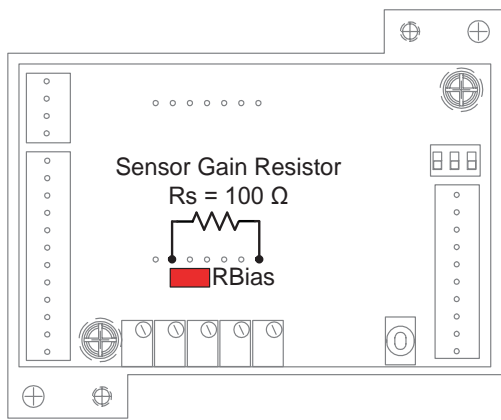

Figure 23. Sensor Gain Resistor and Location of R_{BIAS} — Rev A & B only

ADJUST SENSOR GAIN

If the desired temperature setpoint results in a sensor voltage below 250 mV, the temperature controller may not achieve high levels of precision and stability. In such cases the sensor voltage can be amplified by a factor of 10 by adding a 100 Ω sensor gain resistor (R_s) as shown in **Figure 22**.

Adding the sensor gain resistor to amplify the sensor voltage requires amplifying the setpoint voltage, as well. For example, in a system using a 100 Ω RTD biased at 1 mA, the actual sensor voltage is 110 mV at 25°C. If the R_s resistor is added, the controller will amplify the voltage internally to 1.10 V. The temperature setpoint value, therefore, will also have to be 1.10 V.

USE THE LM335

To use an LM335 sensor refer to **Table 7** for wiring instructions specific to your application. Refer to the sensor datasheet for the external resistor value and temperature transfer function. Change the R_{BIAS} resistor to 2 k Ω .

USE THE AD590

To use an AD590 sensor refer to **Table 7** for wiring instructions specific to your application. Refer to the sensor datasheet for supply voltage requirements and temperature transfer function. Remove R_{BIAS} from the LDTC.

ADJUST THE PHOTODIODE FEEDBACK CURRENT RANGE

The photodiode feedback resistor (R_{31}) is 1 k Ω \pm 1%, which sets the maximum photodiode feedback current to 2 mA. The R_{PD} resistor can be changed in order to adjust the photodiode feedback range.

To locate R_{31} on Rev C only, refer to **Figure 24**.

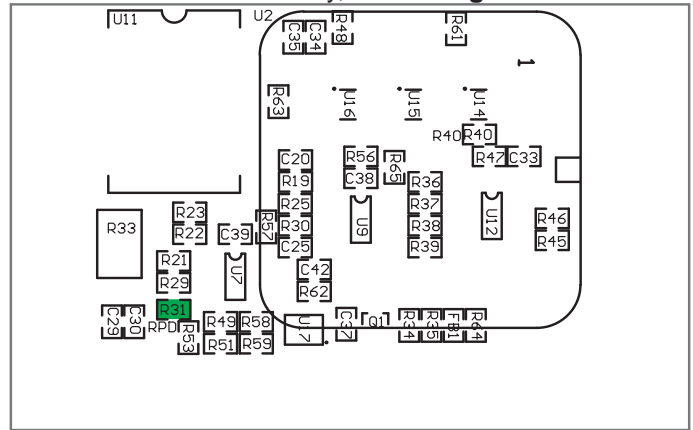

Figure 24. R_{PD} Component Locator (Bottom of Board) — Rev C only

To locate R_{31} on Rev A & B only, refer to **Figure 25**.

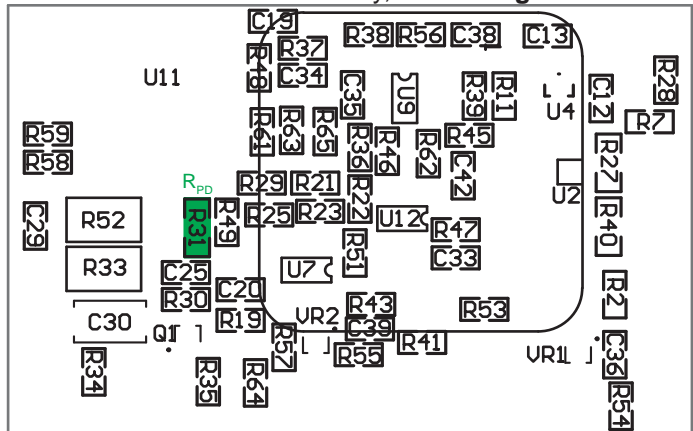

Figure 25. R_{PD} Component Locator (Bottom of Board) — Rev A & B only

To change R_{PD} ,

1. Remove the four screws from the four supports and lift off the PCB to access the parts on the bottom side of the board.
2. Calculate R_{PD} value using **Equation 3** -- I_{PDMAX} is in mA and R_{PD} is in Ω .

Equation 3. Calculate R_{PD}

$$I_{PDMAX} = \left(\frac{2}{R_{PD}} \right)$$

3. Change R31 appropriately.
4. Replace thermal compound on the FL500(s) and reinstall PCB on the supports.

EXTERNAL SETPOINT CIRCUITS

With the TREF and LDREF switches set to EXT (up) the LDTC will reference the analog inputs for the temperature and laser current setpoints, respectively.

In both cases, a benchtop voltage source or DAC can be used to generate the signal, or a simple voltage source circuit can be built; refer to **Figure 26** and **Figure 27**.

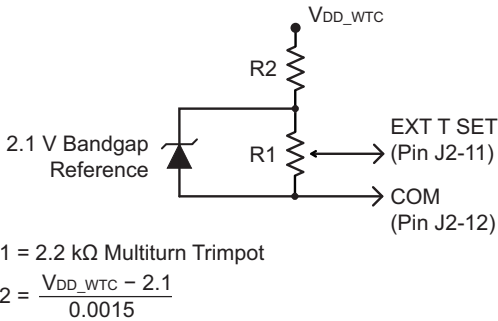

Figure 26. Temperature Controller External Setpoint Circuit

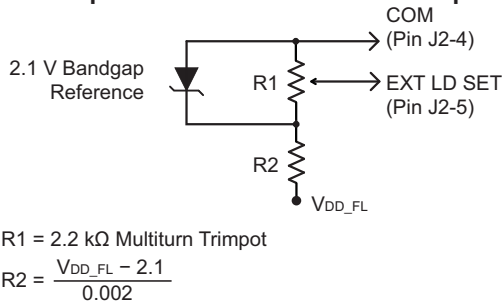

Figure 27. Laser Driver External Setpoint Circuit

AN ALTERNATE METHOD FOR SETTING THE LASER DRIVER CURRENT LIMIT

The laser drive current can be set while using the test load, as recommended on **page 15**, or it can be set while monitoring an internal test point. Using this method, it is not necessary to connect a test load or switch on the driver output, but the cover must be removed from the LDTC.

Refer to the datasheet for your laser diode to find the maximum recommended forward current, I_{LIM} . Then calculate the test point voltage value for the current limit setting. The transfer function is found in **Table 2**, and varies according to the controller model number.

Equation 4. $V_{LD\ I\ LIM} = I_{LIM} / \text{Transfer Function}$

Remove the two screws securing the cover of the LDTCxx20, lift off the cover, and locate the test point above the I LIM trimpot; refer to **Figure 28** for Rev C only and **Figure 29** for Rev A & B only. Connect the positive lead of the DVM to the test point, and the negative lead to one of the ground pins on the J2 connector.

Connect the laser driver power supply and switch it on.

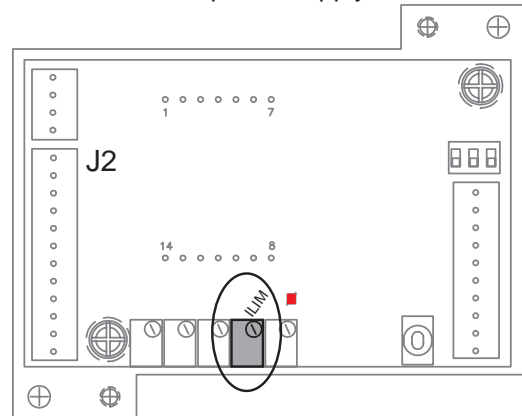

Figure 28. Current Limit Test Point and Trimpot — Rev C only

Adjust the I LIM trimpot until the voltage displayed on the multimeter matches the $V_{LD\ I\ LIM}$ value calculated above.

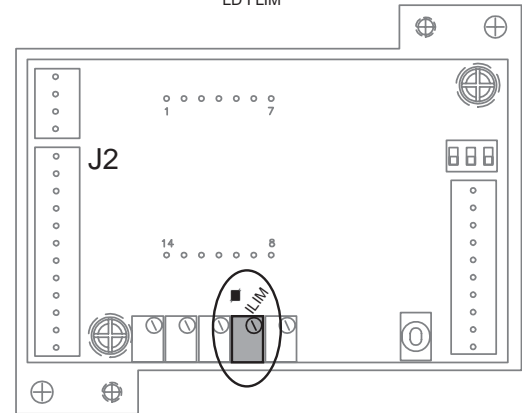

Figure 29. Current Limit Test Point and Trimpot — Rev A & B only

SAFELY TIE THE POWER SUPPLY INPUTS

If the laser diode is case-grounded with the laser anode tied to the case, then special attention must be paid to the power supply wiring.

Figure 30 is a block diagram of the LDT laser controller; internally the V_{DD_FL} pin is connected directly to the laser anode pin.

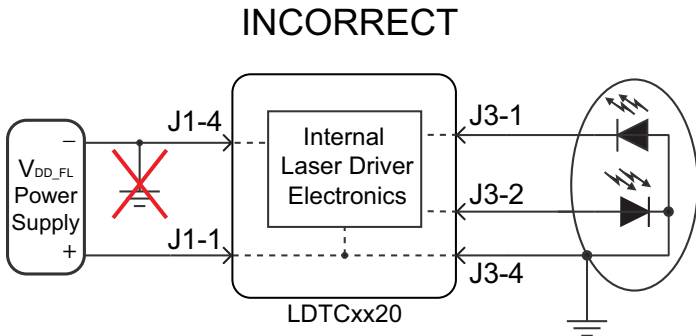

Figure 30. Case-Shorted Laser and Earth-Grounded Power Supply

Note that if the negative terminal of the power supply ground is connected to earth ground, then the power supply is effectively shorted to ground via the laser diode case. The power supply will overheat, blow a fuse, or otherwise fail.

To remedy the situation, connect the GND pin on connector J1 to the negative terminal of the power supply, but not to Earth ground. Refer to **Figure 31**.

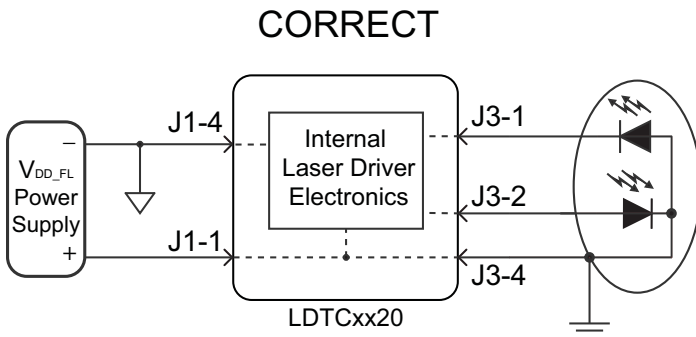

Figure 31. Case-Shorted Laser and Floating-Ground Power Supply

Similarly, if the laser package connects either the TEC or thermistor to the case, then the TE power supplies must be floating with respect to earth ground.

If you have questions about connecting your power supplies, contact the factory immediately.

SAFE OPERATING AREA CALCULATION

To determine if the LDTC controller is suitable for your application and if it will be operating in the safe range, consult the instructions for calculating the Safe Operating Area online at:

Laser Diode Drivers:

<http://www.teamwavelength.com/support/calculator/soa/soald.php>

Temperature Controllers:

<http://www.teamwavelength.com/support/calculator/soa/soatc.php>

If you have any questions about the Safe Operating Area calculator, call the factory for free and prompt technical assistance.



IT IS IMPERATIVE THAT YOU VERIFY THE UNIT WILL OPERATE WITHIN THE INTERNAL HEAT DISSIPATION SAFE OPERATING AREA (SOA).

OPERATING THE CONTROLLER OUTSIDE THE SOA MAY DAMAGE OR DESTROY THE LDTC AND/OR LOADS.

We recommend using the online SOA calculators rather than the charts provided here. The online calculators take into consideration operating temperature, heatsinks, and airflow.

Follow these steps to use the SOA Chart to determine if the LDTC will be operating safely. Refer to the example SOA chart in **Figure 32**. SOA charts for the LDTCxx20 are shown in **Figure 33**, **Figure 34**, and **Figure 35**.

- Determine the V_{DD_FL} supply voltage for the laser driver. For this example assume $V_{DD_FL} = 8$ VDC.
- Refer to the laser datasheet to find the maximum voltage (V_{MAX}) and current (I_{MAX}) specifications. For this example, assume $V_{MAX} = 1.8$ V and $I_{MAX} = 425$ mA.
- Calculate the voltage drop across the controller:

Equation 1.
$$V_{DROD} = V_{DD_FL} - V_{MAX}$$

- Mark V_{DROD} on the X-axis, and extend a line upward
- Mark I_{MAX} on the Y-axis, and extend a line to the right until it intersects the V_{DROD} line
- On the X-axis, mark the supply voltage (V_{DD_FL})
- Extend a diagonal line from V_{DD_FL} to the intersection of the V_{DROD} and I_{MAX} lines; this is the Load Line
- If the Load Line crosses the Safe Operating Area line at any point, the configuration is not safe

If the SOA calculator indicates the LDTC will be outside of the Safe Operating Area, the system must be changed so that less power is dissipated within the driver. See Application Note *AN-LDTC01: The Principle of the Safe Operating Area* for information on shifting the Load Line.

After changing any of the parameters, recalculate the SOA to make sure the controller will operate safely. If you have questions, or run into difficulties calculating the SOA, contact Wavelength Electronics for assistance.

The SOA chart must be examined for both the laser driver and for the temperature controller.

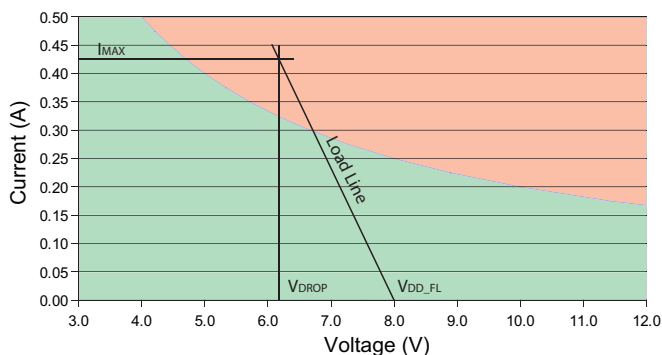

Figure 32. Example SOA Chart, LDTC Laser Driver

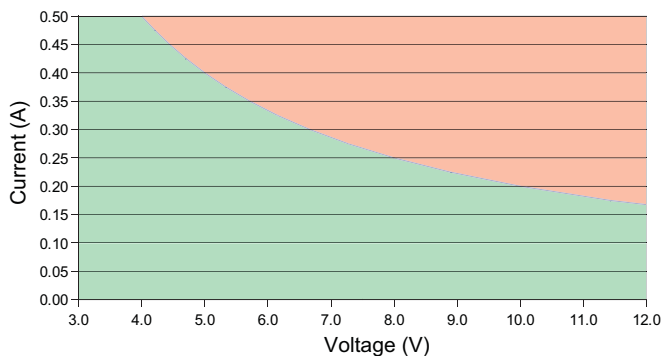

Figure 33. Laser Driver SOA Chart, LDTC0520

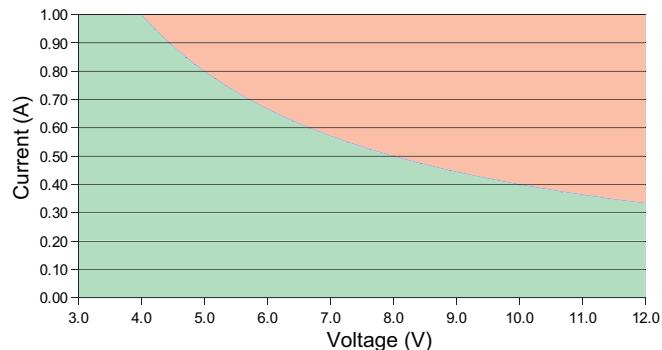

Figure 34. Laser Driver SOA Chart, LDTC1020

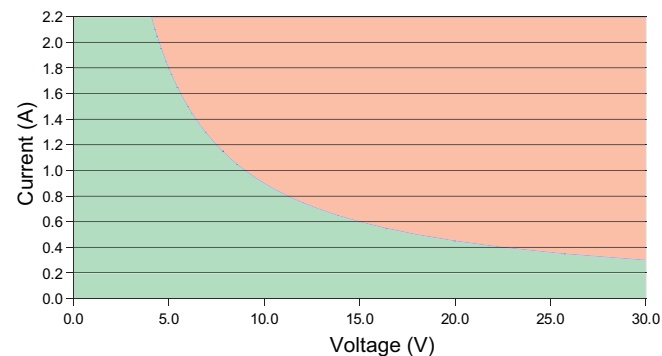

Figure 35. Temperature Controller SOA Chart

TROUBLESHOOTING -- TEMPERATURE CONTROLLER

PROBLEM	POTENTIAL CAUSES	SOLUTIONS
Temperature is decreasing when it should be increasing –OR– Temperature is increasing when it should be decreasing	The TEC may be connected backwards to the LDTC	The convention is that the red wire on the TEC module connects to TEC+ (pin 6) and the black wire to TEC- (pin 5). If your TEC is connected in this manner and the problem persists, the TEC module itself may be wired in reverse. Switch off power to the system, reverse the connections to the LDTC, and then try again to operate the system.
		TEC wiring polarity is dependent on temperature sensor type (NTC vs. PTC). Verify that the polarity is correct for the sensor type you are using (Table 3).
Temperature increases beyond the setpoint and will not come down	The heatsink may be inadequately sized to dissipate the heat from the load and TEC module, and now the system is in a condition called thermal runaway	Increase the size of the heatsink, add a fan to blow air over the heatsink, and/or reduce the ambient air temperature around the heatsink. Apply a thin layer of thermal paste or use thermal washers between the load, the TEC surfaces, and the heatsink.
	The TEC and heatsink are not adequately sized for the thermal load	The heat being generated by the load may be too great for the TEC to pump to the heatsink; a larger TEC may be needed. Consult our technical note <i>TN-TC01: Optimizing Thermoelectric Temperature Control Systems</i> at http://www.teamwavelength.com/downloads/notes/tn-tc01.pdf
The temperature of my heater-based system increases without stopping	The current limits might not be correctly configured	When using a heater the current limit trimpots LIM A and LIM B must be set according to the temperature sensor type you are using. If the load temperature increases past the setpoint and continues to increase, one of the current limit trimpots may have been improperly set. Refer to Table 3 and Set the Temperature Controller Current Limits (page 12) for more information.
Temperature does not stabilize very well at the setpoint	Poor thermal contact between components of the thermal load	Use thermal paste or washers between the load/TEC and TEC/heatsink interfaces. Make sure the temperature sensor is in good thermal contact with the load.
	Operating outside of the ideal region of the temperature sensor	The sensor type and bias current should be selected to maximize sensitivity at the target temperature. Thermistors provide the best performance, particularly for applications where a single setpoint temperature must be accurately maintained. For example, at 25°C a 10 kΩ thermistor has a sensitivity of 43 mV/°C, whereas an RTD sensor has a sensitivity of 4 mV/°C.
	Proportional control term is set too high	Reduce the value of the proportional term. For more information, contact the factory.
Temperature does not reach the setpoint	Insufficient current driven to the TEC or Heater	Increase the current limit - but DO NOT exceed the specifications of the TEC or heater.
	The controller does not have sufficient compliance voltage to drive the TEC or heater	Increase the power supply voltage; be certain to verify that the controller is within the Safe Operating Area; the SOA calculator is found at: http://www.teamwavelength.com/support/calculator/soa/soatc.php
LDTC does not respond to external temperature setpoint input	The TREF switch is improperly configured	To configure the LDTC to reference the setpoint signal on pin J2-11, set the TREF switch to EXT (up).
	The EXT T SET signal is below the minimum signal value of 0.3 V	If the EXT T SET signal falls below 0.3 V, the LDTC defaults to a “safe temperature” setpoint voltage of 1 V (for a 10 kΩ thermistor at 100 μA bias current, the default temperature setpoint is 25°C). The safe temperature setpoint voltage can be changed at the factory if your application requires it. To reset the safety circuit, the EXT T SET signal must be greater than 0.4 V.
Temperature is slow to stabilize and is not within the specifications	Setpoint temperature is set close to the ambient temperature	Set the temperature at least 10°C above ambient when using a resistive heater. A resistive heater is unable to precisely maintain temperature near ambient because once the temperature overshoots the setpoint, the controller turns off and relies on ambient temperature to cool the load. If setting the temperature 10°C or more above ambient is not possible, then choose a thermoelectric controller, which can alternately heat and cool the load to maintain a more precise setpoint temperature.

TROUBLESHOOTING -- LASER DRIVER

PROBLEM	POTENTIAL CAUSES	SOLUTIONS
Driver will not switch on	Improperly configured power supply	Carefully check the wiring diagram on page 2 . Make sure the power supply polarity is not reversed.
	Power supply voltage too low	The LDTC includes brown-out protection circuitry that disables the laser driver if the power supply voltage falls below 2.7 V. Make sure the power supply voltage is correct.
Output will not enable	Improperly configured enable switch on the LDTC	If the LDTC is configured to use the LD SHD remote enable input, the onboard Enable/Disable switch must be set to EN (enable). Make sure this switch is properly set.
	Remote Enable signal is not correct	To enable the laser output, the LD SHD pin must be grounded. Float the pin, or input a 3 to 5 V signal, to disable the output.
Laser output power too low in Constant Current mode	Laser current setpoint too low	Increase the setpoint either by adjusting the I SET trimpot clockwise, or by increasing the signal voltage on the EXT LD SET input (pin J2-5).
	Laser current limit too low	Refer to page 15 for instructions on setting the laser driver current limit.
	Laser driver is compliance limited	Check the laser diode specifications to determine the forward voltage (V_F). Make sure that the LDTCxx20 is not compliance limited. Refer to the Electrical Specifications table on page 7 . If the driver is compliance limited, V_{DD_FL} may need to be increased. Verify that the LDTCxx20 will be operating within the Safe Operating Area if V_{DD_FL} is increased.
Laser does not reach desired output in Constant Power mode	Laser current limit too low	Check the laser diode datasheet to determine the approximate laser drive current at the desired optical power output level. Then verify that the current limit is set slightly higher than that. Refer to page 15 for instructions on setting the laser driver current limit.
	Photodiode feedback current is out of range for the LDTC	Refer to the laser diode datasheet to determine the approximate photodiode (PD) current at the desired output power level. If the PD current exceeds the LDTC PD current range, the LDTC will require modification. Contact the Wavelength Electronics Sales department for assistance.

CABLING SPECIFICATIONS

POWER CABLE -- WCB303; INCLUDED WITH LDTCCXX20



Molex KK 7880 Series Connector
 Housing: Molex 10-11-2043
 Pin: Molex 46999-0101
 36" Long, 22 AWG

PIN	WIRE COLOR
1 - VDD_FL	GREEN
2 - VDD_WTC	RED
3 - VS	WHITE
4 - GND	BLACK

OUTPUT CABLE TO TEC & LD -- WCB301; INCLUDED WITH LDTCCXX20

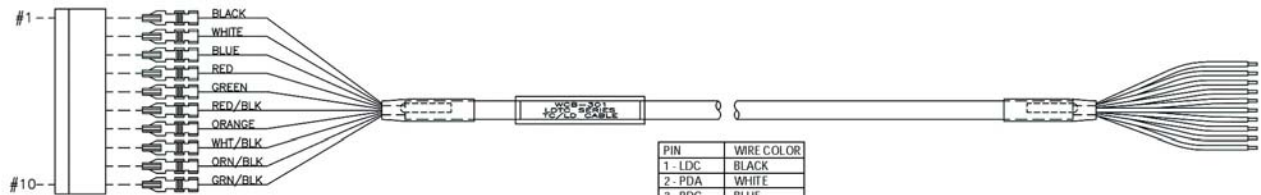

Molex KK 7880 Series Connector
 Housing: Molex 10-11-2103
 Pin: Molex 46999-0101
 36" Long, 22 AWG

PIN	WIRE COLOR
1 - LDC	BLACK
2 - PDA	WHITE
3 - PDC	BLUE
4 - LDA	RED
5 - COM	GREEN
6 - TEC+	RED W/ BLK
7 - TEC-	ORANGE
8 - SEN+	WHT W/ BLK
9 - SEN-	ORG W/ BLK
10 - COM	GRN W/ BLK

I/O CABLE -- WCB302; INCLUDED WITH LDTCCXX20

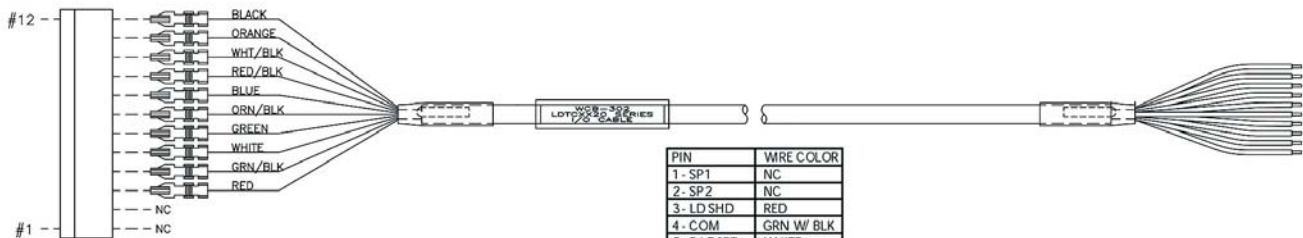

Molex KK 7880 Series Connector
 Housing: Molex 10-11-2123
 Pin: Molex 46999-0101
 36" Long, 22 AWG

PIN	WIRE COLOR
1 - SP1	NC
2 - SP2	NC
3 - LD SHD	RED
4 - COM	GRN W/ BLK
5 - R LDSET	WHITE
6 - COM	GREEN
7 - LD P M	ORG W/ BLK
8 - LD I M	BLUE
9 - ACT T M	RED W/ BLK
10 - SET T M	WHT W/ BLK
11 - R TCSET	ORANGE
12 - COM	BLACK

MECHANICAL SPECIFICATIONS

DIMENSIONS - LDT0520 / LDT1020

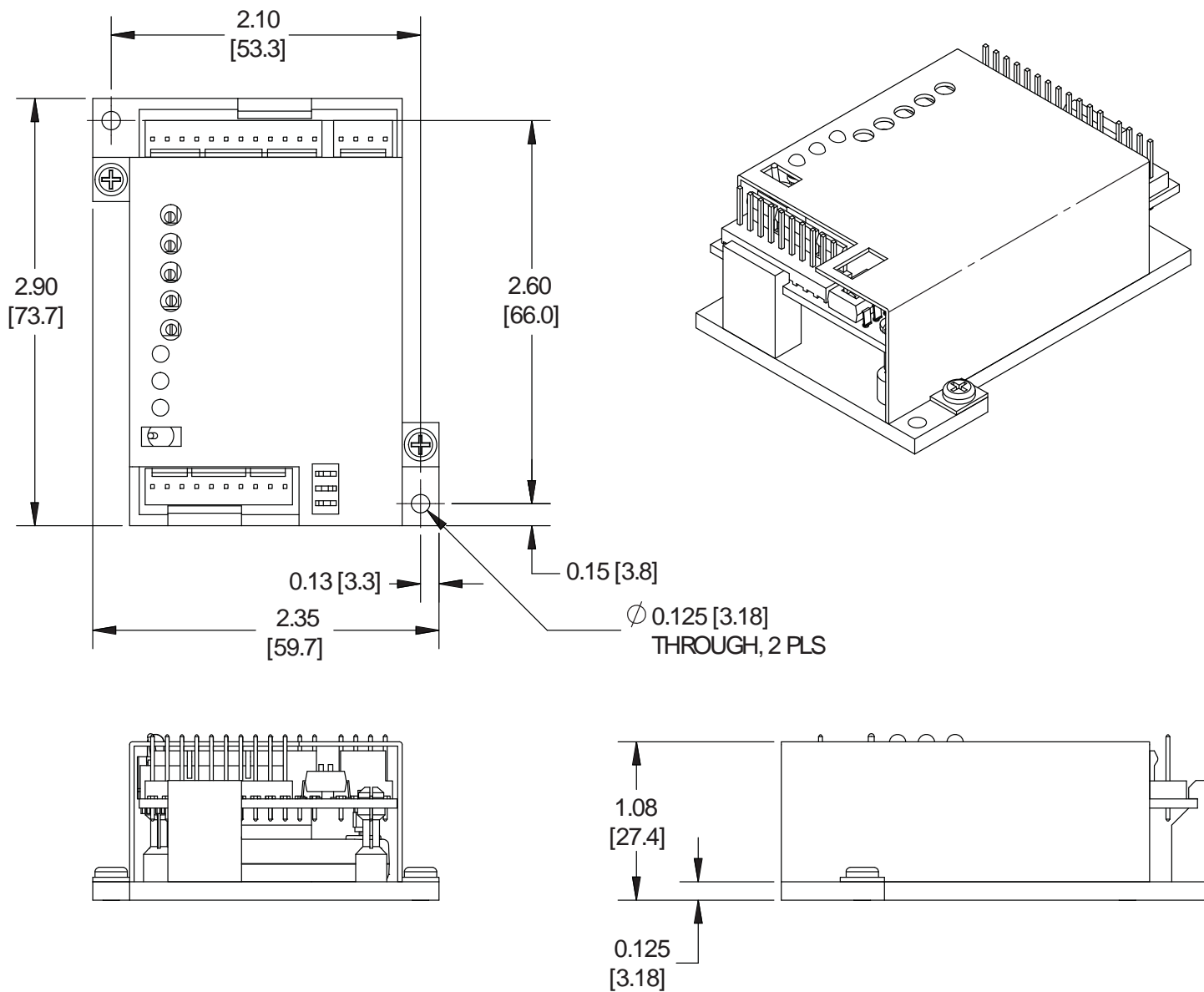

Figure 36. LDT0520 / LDT1020 Dimensions
All Tolerances ±5%; units in inches [mm]

CERTIFICATION AND WARRANTY

CERTIFICATION

Wavelength Electronics, Inc. (Wavelength) certifies that this product met its published specifications at the time of shipment. Wavelength further certifies that its calibration measurements are traceable to the United States National Institute of Standards and Technology, to the extent allowed by that organization's calibration facilities, and to the calibration facilities of other International Standards Organization members.

WARRANTY

This Wavelength product is warranted against defects in materials and workmanship for a period of one (1) year from date of shipment. During the warranty period, Wavelength will, at its option, either repair or replace products which prove to be defective.

WARRANTY SERVICE

For warranty service or repair, this product must be returned to the factory. An RMA is required for products returned to Wavelength for warranty service. The Buyer shall prepay shipping charges to Wavelength and Wavelength shall pay shipping charges to return the product to the Buyer upon determination of defective materials or workmanship. However, the Buyer shall pay all shipping charges, duties, and taxes for products returned to Wavelength from another country.

LIMITATIONS OF WARRANTY

The warranty shall not apply to defects resulting from improper use or misuse of the product or operation outside published specifications. No other warranty is expressed or implied. Wavelength specifically disclaims the implied warranties of merchantability and fitness for a particular purpose.

EXCLUSIVE REMEDIES

The remedies provided herein are the Buyer's sole and exclusive remedies. Wavelength shall not be liable for any direct, indirect, special, incidental, or consequential damages, whether based on contract, tort, or any other legal theory.

REVERSE ENGINEERING PROHIBITED

Buyer, End-User, or Third-Party Reseller are expressly prohibited from reverse engineering, decompiling, or disassembling this product.

NOTICE

The information contained in this document is subject to change without notice. Wavelength will not be liable for errors contained herein or for incidental or consequential damages in connection with the furnishing, performance, or use of this material. No part of this document may be translated to another language without the prior written consent of Wavelength.

SAFETY

There are no user-serviceable parts inside this product. Return the product to Wavelength Electronics for service and repair to ensure that safety features are maintained.

LIFE SUPPORT POLICY

This important safety information applies to all Wavelength electrical and electronic products and accessories:

As a general policy, Wavelength Electronics, Inc. does not recommend the use of any of its products in life support applications where the failure or malfunction of the Wavelength product can be reasonably expected to cause failure of the life support device or to significantly affect its safety or effectiveness. Wavelength will not knowingly sell its products for use in such applications unless it receives written assurances satisfactory to Wavelength that the risks of injury or damage have been minimized, the customer assumes all such risks, and there is no product liability for Wavelength. Examples of devices considered to be life support devices are neonatal oxygen analyzers, nerve stimulators (for any use), auto-transfusion devices, blood pumps, defibrillators, arrhythmia detectors and alarms, pacemakers, hemodialysis systems, peritoneal dialysis systems, ventilators of all types, and infusion pumps as well as other devices designated as "critical" by the FDA. The above are representative examples only and are not intended to be conclusive or exclusive of any other life support device.

REVISION HISTORY

DOCUMENT NUMBER: LDTCI020-00400

REV.	DATE	CHANGE
I	December 2013	Updated test load instructions, extended warranty, added resistive heater stability information
J	August 2014	Updated external setpoint control instructions, and PI equations
K	December 2014	Added Molex part numbers on cabling specs
L	April 2015	Added ESD protection on LD shutdown pin. Updated for product Rev C.



WAVELENGTH
ELECTRONICS

51 Evergreen Drive
Bozeman, Montana 59771

406-587-4910 (tel)
406-587-4911 (fax)

Sales & Tech Support
sales@teamwavelength.com

 techsupport@teamwavelength.com

