



*This product is sold
and supported
in the USA by*



LASER LAB SOURCE
marketplace for **Scientists & Engineers**

contact@LaserLabSource.com

800.887.5065

DATASHEET AND OPERATING GUIDE

WTC3243 & WTC3293

Ultrastable TEC Controller & Evaluation Board



FEATURES AND BENEFITS

- Linear PI Control Stability of 0.0009°C
- Heat and Cool Current Limits
- Adjustable Sensor Bias Current
- Drive ± 2.2 A of TEC or Resistive Heater Current
- Small Size of 1.3" X 1.28" X 0.313"
- Supports Thermistors, RTDs, and IC Sensors
- Single Supply Operation: +5 V to +30 V
- 14-pin DIP PCB Mount
- Monitor Actual Temperature
- Quickly and easily integrated with WTC3293 Evaluation Board

PRECISION, STABILITY & VERSATILITY

The WTC3243 is a compact, analog PI (Proportional, Integral) control loop circuit optimized for use in ultrastable thermoelectric temperature control applications. It easily handles variable operating conditions with a stability of better than 0.0009°C. The temperature setpoint is set by a remote voltage signal. It is capable of controlling both thermoelectric and resistive heaters, and only five external resistors are needed to optimize the controller for your specific application.

The WTC3293 Evaluation Board is available to quickly integrate the WTC3243 into your system and can be optimized for sensor type. Use the adjustable trimpots to configure heat and cool current limits, proportional gain, and integrator time constant.

BUILT-IN SAFETY

To protect the device, heat and cool limits can be set independently. This safety feature guarantees that your thermoelectric cooler will never be driven beyond your specified limits.

LEADING EDGE APPLICATIONS

The robust and reliable WTC3243 has been designed into electro-optical systems, airborne instrumentation, spectroscopic monitors, and medical diagnostic equipment. It is particularly well-suited to applications where temperature is scanned across ambient.

CONTENTS

	PAGE
QUICK CONNECT GUIDE	2
WTC3293 EVALUATION BOARD SCHEMATIC	4
PIN DESCRIPTIONS – WTC3243	5
PIN DESCRIPTIONS – WTC3293 EVAL BOARD	6
ELECTRICAL SPECIFICATIONS – WTC3243	8
SAFETY & THERMAL DESIGN CONSIDERATIONS	11
OPERATING INSTRUCTIONS – WTC3243 + EVAL	12
DESIGN GUIDE – WTC3243	20
ADDITIONAL TECHNICAL NOTES	28
TROUBLESHOOTING	32
MECHANICAL SPECIFICATIONS	34
CERTIFICATION AND WARRANTY	36

ORDERING INFORMATION

PART NO	DESCRIPTION
WTC3243	± 2.2 A Temperature Controller
WTC3243HB	± 2.2 A Li-Ion Battery-Compatible Temperature Controller
WTC3293	Evaluation Board for WTC3243 Temperature Controller
WEV300	Thermal Management Kit, no fan
WEV301	Thermal Management Kit, 5 V fan
WEV302	Thermal Management Kit, 12 V fan

The prior revision of the evaluation board was black. Click <http://www.teamwavelength.com/downloads/datasheets/wtc3293a.pdf> for the datasheet for the WTC3293 revision A.

406-587-4910
www.teamWavelength.com

Applies to WTC3243 Revisions A - C
 WTC3243HB Revisions A - C
 WTC3293 Revision B
 © August 2015

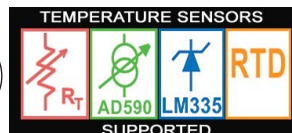

WAVELENGTH
 ELECTRONICS

QUICK CONNECT GUIDE

WTC3243 Temperature Controller Pin Layout	page 2
WTC3293 Evaluation Board Top view	page 2
WTC3243 Controller Quick Connect Diagram	page 3
WTC3243 Test Loads	page 3
WTC3293 Eval Board Electrical Schematic	page 4



TO ENSURE SAFE OPERATION OF THE WTC3243 THERMOELECTRIC CONTROLLER, IT IS IMPERATIVE THAT YOU DETERMINE THAT THE UNIT WILL BE OPERATING WITHIN THE INTERNAL HEAT DISSIPATION SAFE OPERATING AREA (SOA).

Visit the Wavelength Electronics website for the most accurate, up-to-date, and easy to use SOA calculator:

<http://www.teamwavelength.com/support/calculator/soa/soatc.php>

Figure 1 shows the pin layout and descriptions for the WTC3243.

IF YOU ARE UPGRADING FROM THE WHY5640: The position of Pin 1 on the WHY5640 is reversed (or mirrored) relative to the position of Pin 1 on the WTC3243.

Figure 2 is the top view of the WTC3293, illustrating the onboard switches, trimpots, and connectors.

Figure 3 is the Quick Connect schematic for the WTC3243 using a thermistor temperature sensor.

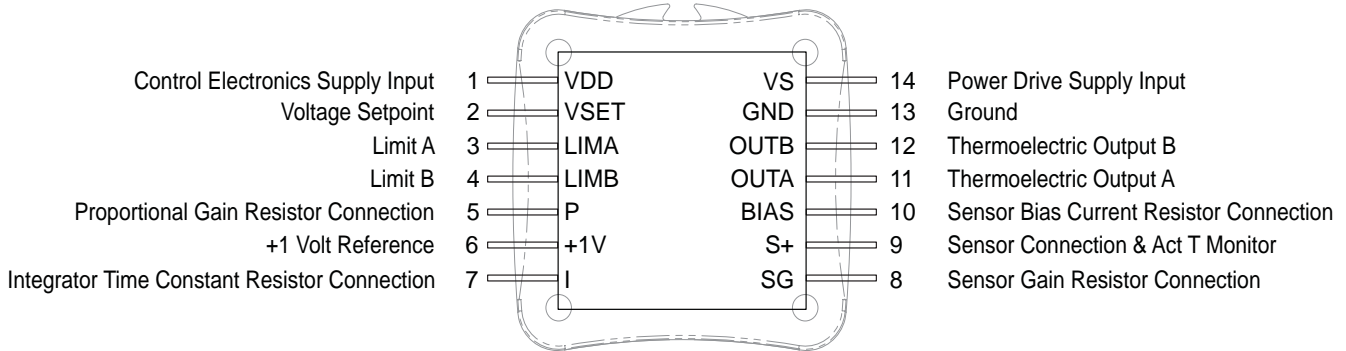

Figure 1. WTC3243 Pin Layout -- Top View

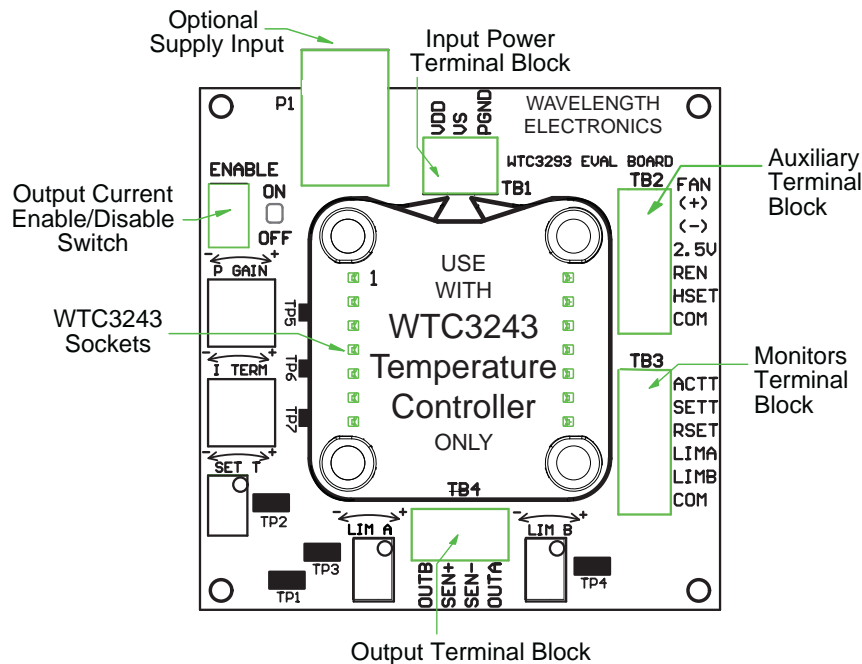
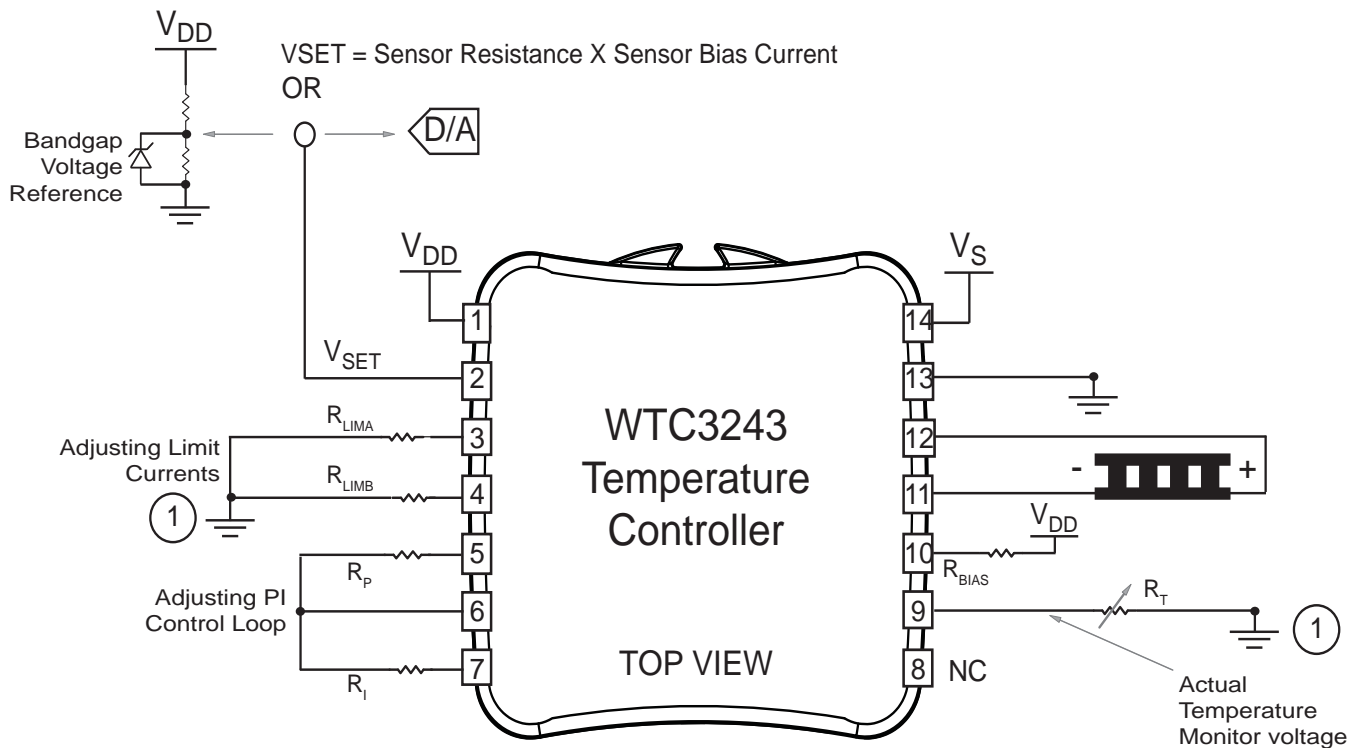

Figure 2. WTC3293 Evaluation Board Top View

QUICK CONNECT GUIDE, cont'd



① TIE GROUND CONNECTIONS DIRECTLY TO PIN 13

Figure 3. WTC3243 Quick Connect for TEC with Thermistor

QUICK CONNECT LEGEND				
FUNCTION	WTC3243 & EVAL BOARD		WTC3243 ALONE	
Limits	Adjust LIMA & LIMB	Table 6 on page 17 Equation 5	R_{LIMA} & R_{LIMB}	Table 9 on page 25
Control Parameters	PGAIN	Table 5 on page 14 Equation 1	R_P	Table 11 on page 27
	I TERM	Table 5 on page 14 Equation 3	R_I	Table 12 on page 27
Bias Current	Sensor Bias Switch	Table 4 on page 13 Figure 8	R_{BIAS}	Table 10 on page 26 Equation 6 & Equation 7
	Gain Jumper	Table 10 on page 26 Figure 9	R_G	Table 10 on page 26 Equation 8
Thermistor (R_T)	See Thermistor datasheet			

The same values can more simply be determined using the Circuit Design Calculator, available online at: <http://www.teamwavelength.com/support/calculator/wtc/default.php>. Wavelength recommends using this utility.

RECOMMENDED TEST LOAD

For setup and configuration, we recommend using a test load in place of the TEC or resistive heater, connected directly to Pin 11 and Pin 12 on the controller, as shown in Figure 4.

Recommended test load:

- MP9100-1.00-1%. This resistor may need to be attached to a heatsink.

We also recommend using a test circuit to simulate a 10 kΩ thermistor. Figure 4 shows a simple adjustment test circuit.

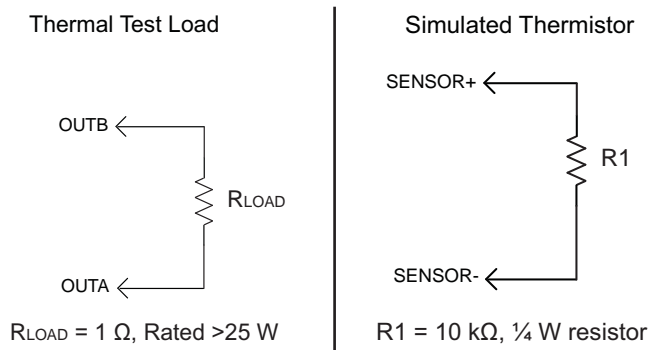
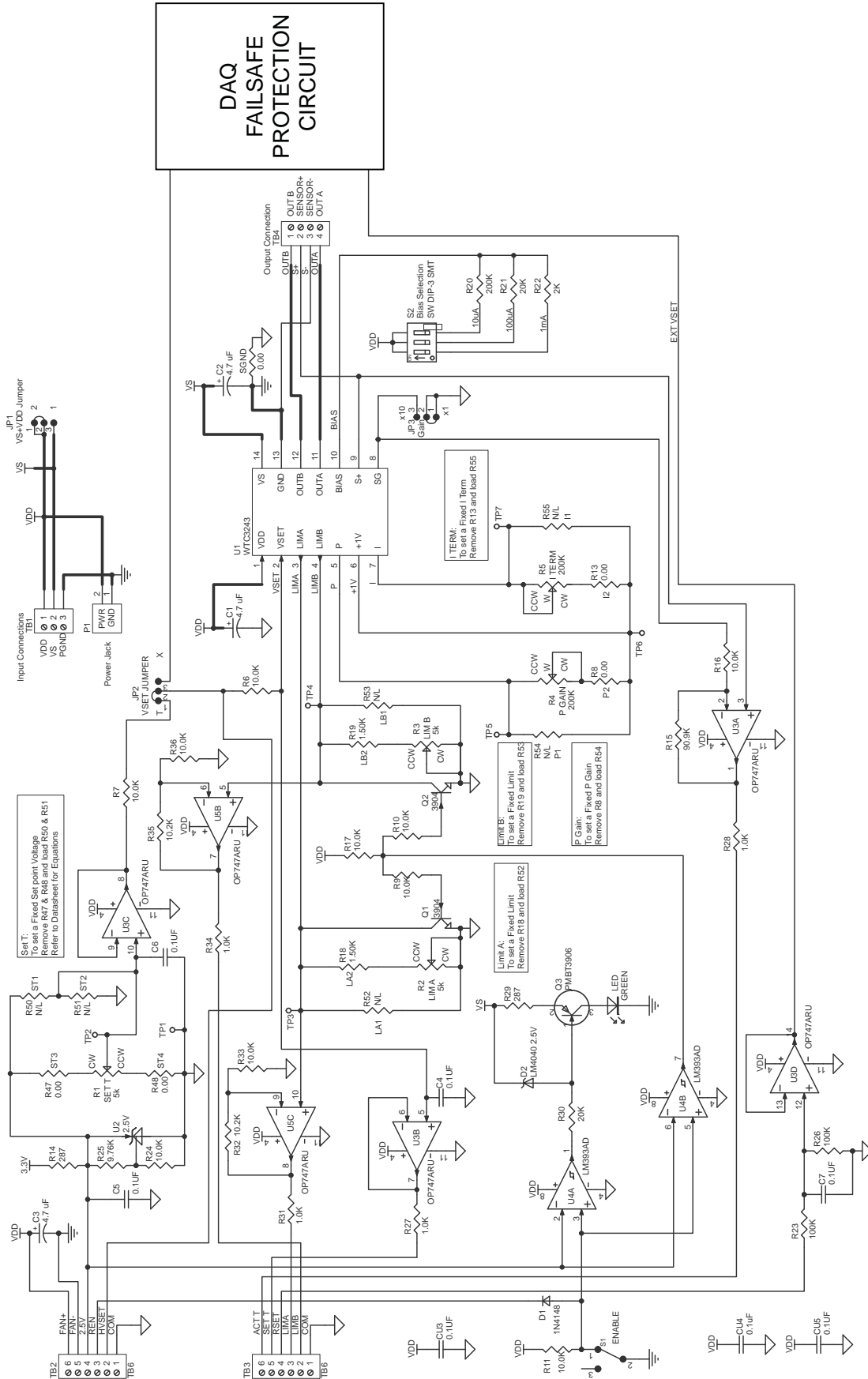

Figure 4. Recommended Test Loads

WTC3293 EVALUATION BOARD SCHEMATIC



PIN DESCRIPTIONS – WTC3243

Table 1. WTC3243 Temperature Controller Pin Descriptions

PIN	NAME	PIN DESCRIPTION
1	VDD	Control Electronics Power Supply Input. Connect a +4.5 V to +30 V power supply to VDD (Pin 1) and GND (Pin 13). NOTE: can be connected to VS (Pin 14).
2	VSET	Voltage Setpoint [Setpoint voltage equations are sensor dependent & noted on operating diagrams]. Connect a voltage source between VSET (Pin 2) and GND (Pin 13) to control the temperature setting.
3	LIMA	Limit A. A resistor connected between LIMA (Pin 3) and GND (Pin 13) limits the output current drawn off the VS (Pin 14) supply input to OUTA (Pin 11).
4	LIMB	Limit B. A resistor connected between LIMB (Pin 4) and GND (Pin 13) limits the output current drawn off the VS (Pin 14) supply input to OUTB (Pin 12).
5	P	Proportional Gain Resistor Connection. Connect a resistor between P (Pin 5) and +1V (Pin 6) to configure the Proportional Gain setting.
6	+1V	+1 Volt Reference.
7	I	Integrator Time Constant Resistor Connection. Connect a resistor between I (Pin 7) and +1V (Pin 6) to configure the Integrator Time Constant setting.
8	SG	Sensor Gain Resistor Connection. Connect a resistor between SG (Pin 8) and GND (Pin 13) to adjust the Sensor Gain setting.
9	S+	Sensor Connection. Connect resistive and LM335 type temperature sensors across S+ (Pin 9) and GND (Pin 13). Connect a 10 k Ω resistor across S+ (Pin 9) and GND (Pin 13) when using AD590 type temperature sensors. The negative terminal of the AD590 sensor connects to S+ (Pin 9) and the positive terminal to VDD (Pin 1). AD590 operation requires that VDD be +8 V or greater.
10	BIAS	Sensor Bias Current Resistor Connection. Connect a resistor between BIAS (Pin 10) and VDD (Pin 1) to configure the sensor bias current.
11	OUTA	Thermoelectric Output A. Connect OUTA (Pin 11) to the negative terminal on your thermoelectric when controlling temperature with Negative Temperature Coefficient (NTC) thermistors. With NTC sensors the TEC current will flow from OUTA to OUTB (Pin 12) when heating (opposite polarity for PTC sensors). Connect OUTA (Pin 11) to the positive thermoelectric terminal when using Positive Temperature Coefficient (PTC) RTDs, LM335 type, and AD590 type temperature sensors.
12	OUTB	Thermoelectric Output B. Connect OUTB (Pin 12) to the positive terminal on your thermoelectric when controlling temperature with Negative Temperature Coefficient (NTC) thermistors. With NTC sensors the TEC current will flow from OUTB to OUTA (Pin 11) when cooling (opposite polarity for PTC sensors). Connect OUTB (Pin 12) to the negative thermoelectric terminal when using Positive Temperature Coefficient (PTC) RTDs, LM335 type, and AD590 type temperature sensors.
13	GND	Ground. Connect the power supply ground connections to GND (Pin 13). All ground connections to this pin should be wired separately.
14	VS	Power Drive Supply Input. Provides power to the WTC3243 H-Bridge power stage. Supply range input for this pin is +3 to +30 Volts DC. The maximum current drain on this terminal should not exceed 2.2 A. CAUTION: Care should be taken to observe the maximum internal power dissipation limits before applying power to the device. NOTE: can be connected to VDD (Pin 1).

IF YOU ARE UPGRADING FROM THE WHY5640: The position of Pin 1 on the WHY5640 is reversed (or mirrored) relative to the position of Pin 1 on the WTC3243.

PIN DESCRIPTIONS – WTC3293 EVALUATION BOARD

Table 2. WTC3293 Evaluation Board Pin Descriptions

SILKSCREEN LABEL	NAME	FUNCTION
P1	Power	Optional Supply Input. 2.5 mm jack power connection to V_{DD} . NOTE: Use either Input Supply (P1) or V_{DD} on TB1 but not both.
ENABLE ON/OFF	Output Current ON/OFF	Output Current Enable/ Disable Switch. Turns output current on and off. NOTE: Keep this OFF until the evaluation board is set up entirely. LED lights when ON.
P GAIN	Trimpot	Proportional Gain
I TERM	Trimpot	Integrator Time Constant
SET T	12-turn Trimpot	Setpoint for temperature
LIM A	12-turn Trimpot	Current Limit A Adjustment
LIM B	12-turn Trimpot	Current Limit B Adjustment
TP1	Test Point 1	Used when eliminating trimpots in setpoint and limit circuits
TP2	Test Point 2	
TP3	Test Point 3	
TP4	Test Point 4	
TP5	Test Point 5	P GAIN (measure resistance across TP5 and TP6)
TP6	Test Point 6	Reference point for P GAIN and I TERM
TP7	Test Point 7	I TERM (measure resistance across TP6 and TP7)
Terminal Block 1 (TB1), Input Power Terminal Block		
V_{DD}	Voltage Supply	Power supply input for control electronics. Directly connected to WTC3243 V_{DD} (Pin 1). NOTE: Use either Input Supply (P1) or V_{DD} on TB1 but not both.
V_s	Voltage Supply	Power supply input for output stage. Directly connected to WTC3243 V_s (Pin 14)
PGND	Power Ground	Directly connected to WTC3243 GND (Pin13)
Terminal Block 2 (TB2), Auxiliary Terminal Block		
FAN +	Fan Positive	Red wire connection
FAN -	Fan Ground	Black wire connection
2.5 V	+2.5 V Reference	Reference voltage for use with external setpoint circuit
REN	Remote Enable	0 V = ENABLED Floating or >3 V = DISABLED The onboard switch overrides the external signal.
HSET	High Voltage Setpoint	Remote setpoint voltage is not subject to the DAQ Failsafe Protection Circuit
COM	Common Ground	Low noise ground reference for control signals
Terminal Block 3 (TB3), Monitors Terminal Block		
ACTT	Actual Temperature (Sensor Voltage)	The actual temperature monitor voltage matches the voltage drop across the temperature sensor. Transfer function is 1 V / V.
SETT	Setpoint Voltage Monitor	The setpoint temperature monitor voltage matches the setpoint voltage at Pin 2 on the WTC3243. Transfer function 1 V / V.
RSET	Remote setpoint	Remote setpoint voltage is subject to DAQ Failsafe Protection Circuit
LIMA	Limit A	Voltage at Pin 3 on the WTC3243
LIMB	Limit B	Voltage at Pin 4 on the WTC3243
COM	Common Ground	Low noise ground reference for monitor signals
Terminal Block 4 (TB4), Output Terminal Block		
OUTB	Output B	Direct connection to WTC3243 OUTB (Pin 12)
SEN+	Sensor positive	Direct connection to WTC3243 S+ (Pin 9)
SEN-	Sensor negative	Direct connection to WTC3243 GND (Pin 13)
OUTA	Output A	Direct connection to WTC3243 OUTA (Pin 11)

Table 3. Control and Monitor Transfer Functions

FUNCTION	WTC3243	WTC3243HB	WTC3293	DESCRIPTION
RSET to Sensor Voltage		1 V / V		The controller drives the TEC or heater to make the voltage across the sensor match the RSET voltage.
SET T Monitor to VSET		1 V / V		The setpoint temperature monitor voltage matches the setpoint voltage.
ACT T Monitor to Sensor Voltage		1 V / V		The actual temperature monitor voltage matches the voltage drop across the temperature sensor.

ELECTRICAL SPECIFICATIONS – WTC3243

ABSOLUTE MAXIMUM RATINGS	SYMBOL	WTC3243	WTC3243HB	UNIT	NOTE
Supply Voltage 1	V_{DD}	+4.5 to +30	+3 to +5.5	Volts DC	Voltage on Pin 1 Can be connected to V_S Consult SOA Calculator
Supply Voltage 2	V_S	+3 to +30	+3 to +8	Volts DC	Voltage on Pin 14 Can be connected to V_{DD} Consult SOA Calculator
Power Dissipation	P_{MAX}	9		Watts	$T_{AMBIENT} = +25^{\circ}C$ See SOA Chart -- with fan and heatsink
Case Operating Temperature	T_{OPR}	-40 to +85		$^{\circ}C$	
Case Storage Temperature	T_{STG}	-65 to 150		$^{\circ}C$	

PARAMETER	SYMBOL	WTC3243	WTC3243HB	UNIT	NOTE
OUTPUT CURRENT					
Maximum Output Current	I_{OUT}	± 2.0 to ± 2.2	± 2.2	Amps	
Compliance Voltage, OUTA to OUTB		$V_S - 0.1$		Volts	Full temp. range, $I_{OUT} = 100$ mA
Compliance Voltage, OUTA to OUTB		$V_S - 0.3$		Volts	Full temp. range, $I_{OUT} = 1$ A
Compliance Voltage, OUTA to OUTB		$V_S - 0.6$		Volts	Full temp. range, $I_{OUT} = 1.5$ A
Compliance Voltage, OUTA to OUTB		$V_S - 0.9$		Volts	Full temp. range, $I_{OUT} = 2.0$ A
Compliance Voltage, Resistive Heater		$V_S - 1.0$		Volts	Full temp. range, $I_{OUT} = 2.2$ A
Short Term Stability (1 hour)		0.0009		$^{\circ}C$	OFF ambient temperature TSET = $25^{\circ}C$ using 10 k Ω thermistor ⁽¹⁾
Short Term Stability (1 hour)		0.002		$^{\circ}C$	ON ambient temperature TSET = $25^{\circ}C$ using 10 k Ω thermistor ⁽¹⁾
Long Term Stability (24 hours)		0.002		$^{\circ}C$	OFF ambient temperature TSET = $25^{\circ}C$ using 10 k Ω thermistor ⁽¹⁾
POWER SUPPLY					
Power Supply Voltage		$V_{DD} = +4.5$ to +30 $V_S = +3$ to +30	$V_{DD} = +3$ to +5.5 $V_S = +3$ to +8	Volts	
Quiescent Current		$V_{DD-QUIESCENT} = 8$ $V_{S-QUIESCENT} = 2.5$		mA	
Minimum Current Rating		$V_{DD} = 1.1 * V_{DD-QUIESCENT}$ $V_S = 1.1 * (I_{TEC} + V_{S-QUIESCENT})$		Amps	
TEMPERATURE SENSORS					
Sensor Compatibility		Thermistors, RTD, IC Sensors			
Sensor Input Voltage Range		GND to $V_{DD} - 2$		Volts	Limited by bias current circuit ⁽²⁾
Sensor Input Damage Threshold		$> V_{DD} + 0.7$ or < -0.7		Volts	Without the bias current circuit

⁽¹⁾ When using resistive heaters, stability can only be consistently achieved when specified temperatures are $10^{\circ}C$ or more above ambient.

⁽²⁾ The bias source has a compliance up to $V_{DD} - 2$ V. In normal operation this limits the sensor voltage range from 0 V to $V_{DD} - 2$ V. While voltages up to ± 5 V outside this range on the VSET pin will not damage the unit, it will not provide proper control under these conditions.

PARAMETER	SYMBOL	WTC3243	WTC3243HB	UNIT	NOTE
VSET					
Input Impedence	VSET	1		MΩ	
VSET Damage Threshold	VSET	> $V_{DD} + 0.7$ or < -0.7		Volts	
Setpoint vs. Actual T Accuracy		<2		%	Rev. B TSET = 25°C using 10 kΩ thermistor
BIAS CURRENT					
Bias Current Accuracy		1		%	Include the tolerance of the bias current resistor
THERMAL					
Heatspreader Temperature Rise		+28 to +33		°C / W	$T_{AMBIENT} = 25^{\circ}\text{C}$
Heatspreader Temperature Rise		+18 to +25		°C / W	With WHS302 Heatsink & WTW002 Thermal Washer
Heatspreader Temperature Rise		+3.1 to +3.9		°C / W	With WHS302 Heatsink, WTW002 Washer, and 3.5 CFM Fan
FEEDBACK LOOP					
Proportional Gain	PGAIN	1 - 100		A / V	
Integrator Time Constant	ITERM	0.53 - 4.5		Seconds	

ELECTRICAL SPECIFICATIONS – WTC3293 + WTC3243

PARAMETER	SYMBOL	WTC3293	UNIT	
POWER SUPPLY				
Power Supply Voltage		$V_{DD} = +4.5$ to $+30$ $V_S = +3$ to $+30$	Volts	Enable LED will not turn on when less than 3.5 V
Quiescent Current		$V_{DD-QUIESCENT} = 8$ $V_{S-QUIESCENT} = 10.5$	mA	
Fan Current Draw		5 V fan → 150 12 V fan → 100	mA	
Minimum Current Rating		$V_{DD} = 1.1 * (V_{DD-QUIESCENT} + \text{fan})$ $V_S = 1.1 * (I_{TEC} + V_{S-QUIESCENT})$	Amps	
BIAS CURRENT				
Bias Current Selection		10 μ A, 100 μ A, 1 mA, 10 mA		
Bias Current Accuracy		1	%	
EXTERNAL SETPOINT AND MONITORS				
RSET Voltage Range		0 - 6.5	Volts	
RSET Damage Threshold	RSET	< -0.7 or $> \min(V_{DD} + 0.7, 6.5)$	Volts	RSET low end is affected by the DAQ Failsafe Protection circuit
HSET Voltage Range		0 - $[V_{DD} - 2.5]$	Volts	
HSET Damage Threshold	HSET	< -0.7 or $> V_{DD} + 0.7$	Volts	
SET T MON output voltage range		0 - 6.5 (VSET = X) 0 - 2.5 (VSET = T)	Volts	X is the external setpoint jumper T is the internal trimpot jumper
ACT T MON output voltage range		0 to V_{DD}	Volts	Limited by bias current circuit ⁽¹⁾
Sensor Voltage to ACT T MON Accuracy		0.1 to 1	mV	
SET T MON to ACT T MON Accuracy		0.1 to 3 (2 typical)	mV	
RSET T (or HSET T) vs. SET T MON Accuracy		0.1	mV	
Input Impedance	RSET	200	k Ω	
	HSET	1	M Ω	
FEEDBACK LOOP				
Proportional Gain	PGAIN	1 - 65	A / V	With different resistor, Proportional Gain range can be increased to 100 A / V.
Integrator Time Constant	ITERM	0.53 - 4.5	Seconds	Integrator trimpot turned fully clockwise (CW) = longer time constant, lower resistance. Trimpot turned fully counter-clockwise (CCW) = shorter time constant, higher resistance.

⁽¹⁾ The bias source has a compliance up to $V_{DD} - 2$ V. In normal operation this limits the sensor voltage range from 0 V to $V_{DD} - 2$ V. While voltages up to ± 5 V outside this range on the VSET pin will not damage the unit, it will not provide proper control under these conditions.

SAFETY INFORMATION & THERMAL DESIGN CONSIDERATIONS

SAFE OPERATING AREA – DO NOT EXCEED INTERNAL POWER DISSIPATION LIMITS



TO ENSURE SAFE OPERATION OF THE WTC3243 THERMOELECTRIC CONTROLLER, IT IS IMPERATIVE THAT YOU DETERMINE THAT THE UNIT WILL BE OPERATING WITHIN THE INTERNAL HEAT DISSIPATION SAFE OPERATING AREA (SOA).

Visit the Wavelength Electronics website for the most accurate, up-to-date, and easy to use SOA calculator:
<http://www.teamwavelength.com/support/calculator/soa/soatc.php>

For more information on Safe Operating Area, see our Application Note [AN-LDTC01: The Principle of the Safe Operating Area](#).

PREVENT DAMAGE FROM ELECTROSTATIC DISCHARGE

Before proceeding, it is critical that you take precautions to prevent electrostatic discharge (ESD) damage to the driver and your laser. ESD damage can result from improper handling of sensitive electronics, and is easily preventable with simple precautions.

Enter the search phrase “ESD Precautions for Handling Electronics” in an internet search engine to find information on ESD-safe handling practices.

We recommend that you always observe ESD precautions when handling the WTC controller.

THEORY OF OPERATION

The WTC3243 is a linear temperature controller that delivers bidirectional current to Peltier Effect thermoelectric coolers (TEC), or unidirectional current to resistive heaters.

The fundamental operating principle is that the controller adjusts the TEC drive current in order to change the temperature of the sensor that is connected to the thermal load. The goal is to make the voltage across the sensor match the setpoint voltage, and then keep them equal in spite of changes to ambient conditions and variations in thermal load.

The controller measures the load temperature by driving a current through the temperature sensor and measuring the voltage drop across it. It may be useful to remember that you do not directly adjust the setpoint temperature. Rather, you adjust a voltage signal that represents the sensor voltage at the desired temperature setpoint.

While the output is enabled the controller continuously compares the setpoint voltage and the actual sensor voltage. If there is a difference between the two signals the controller adjusts the output current—thereby driving the TEC or heater to change temperature—until the difference is zero.

Once the actual sensor voltage equals the setpoint voltage, the controller makes minor adjustments to the output current in order to keep the difference at zero. If the ambient temperature changes, for example, the controller will adjust the drive current accordingly.

The controller includes features that help protect the load from damage, and also make it more versatile in a wide array of applications. These features are explained in detail in **Operating Instructions — WTC3243 + EVAL BOARD on page 12.**

- **Current limit:** Independent heating and cooling current limits avoid over-driving and damaging the TEC or heater.
- **External or Onboard temperature setpoint control:** for prototyping and benchtop applications the temperature setpoint can be adjusted with the onboard trimpot on the evaluation board. When the controller is integrated into an automated control system, the temperature setpoint can be adjusted by an external voltage signal.
- **Local Enable on WTC3293 Evaluation Board:** the controller can be configured so that the output is always on whenever power is applied to the unit.
- **Control loop:** the controller employs a smart Proportional-Integrating control loop to adjust the drive current. The proportional term is user-adjustable, and when properly configured will quickly settle the load to temperature with minimal overshoot and ringing.

OPERATING INSTRUCTIONS – WTC3243 + EVAL BOARD

WTC3243 WITH WTC3293 EVAL BOARD

Operate the WTC3243 quickly using the WTC3293 Evaluation Board. For integrating the WTC3243 into a custom printed circuit board, see **Design Guide – WTC3243 on page 20**.

NECESSARY EQUIPMENT

The following equipment is the minimum necessary to configure the WTC and evaluation board for basic operation.

- WTC3243 Temperature Controller
- WTC3293 PCB evaluation board
- Digital multimeter, 4-½ digit resolution recommended
- Thermistor or other temperature sensor
- Peltier-type thermoelectric module or resistive heater
- Optional: test load
- Minimum 22 gauge wiring
- Power Supplies (see below)
- Thermal Solutions Kit, if operating above 5 V or 500 mA
- Small flathead screwdriver or Tweaker (included)

SYSTEM DESIGN DECISIONS

Before the WTC3293 Evaluation Board can be configured, several decisions must be made:

- What sensor is being used?
- What bias current is needed?
- What is the operating maximum current and maximum voltage?
- Will the power supply be a single or dual supply?
- Will the system, as designed, fit within the Safe Operating Area (SOA)?

POWER SUPPLY REQUIREMENTS

The V_{DD} power supply is used to power the WTC3243 internal control electronics and must be capable of sourcing a minimum of 8 mA of current. If a fan is needed, the fan draw current on V_{DD} will also need to be added to the minimum required current.

V_S powers the WTC3243 output stage and must be sufficient to provide 1.1 times quiescent current and TEC current.

$$V_S = 1.1 * (I_{TEC} + V_{S_QUIESCENT})$$

For V_S , when selecting a power supply, choose a voltage as close to the operating voltage of the TEC as possible to maximize efficiency and minimize the WTC internal power dissipation.

CONFIGURE THE JUMPERS & SWITCH

On the underside of the WTC3293 Evaluation Board you will find the jumpers and switches. Use **Figure 5** below to locate them.

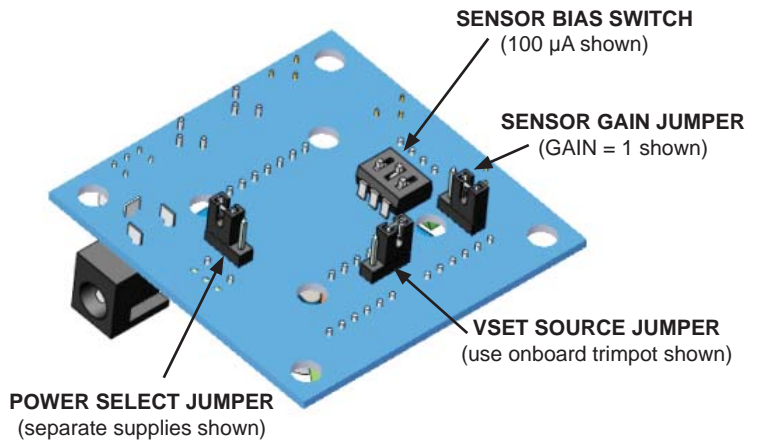

Figure 5. Bottom View, Jumper Locations -- Factory Default

SET THE POWER SELECT JUMPER

V_S drives the output stage while V_{DD} powers the control electronics. **Figure 5** shows the jumper location and **Figure 6** shows the jumper position. The factory default is to separate the V_S and V_{DD} power supply inputs.

- To use Single Supply Operation, place the jumper in the $V_S + V_{DD}$ or “1” position. Note that when in this position, V_S on the input terminal block pin will be at the same potential as the V_{DD} pin.
- To use Dual (separate) Supply Operation, place the jumper in the V_{DD} or “2” position.

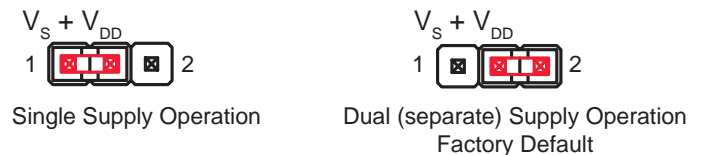

Figure 6. Power Select Jumper Settings

SET THE VSET SOURCE JUMPER

Figure 7 shows the jumper positions and Figure 8 shows the jumper location.

- To use the onboard trimpot to generate the setpoint voltage (VSET), move the jumper to the trimpot or “T” position.
- To use an external voltage source through the remote setpoint (RSET) input, move the jumper to the external or “X” position.
- To use the high voltage setpoint (HSET) input, completely remove the jumper. Using the HSET setting bypasses the Data Acquisition Failsafe Protection circuit.

NOTE: When the VSET SOURCE jumper is in the “X” position or removed, the voltage dialed in using the SET T trimpot on the WTC3293 is ignored.



Figure 7. VSET Source Jumper Settings

SET THE SENSOR BIAS SWITCH

Use Table 4 to configure the evaluation board for your temperature sensor type. Sensor signal at SEN+ (TB4) should not exceed ($V_{DD} - 2 V$). The minimum recommended signal is 250 mV in order to meet published specifications. Figure 8 shows the switch location.

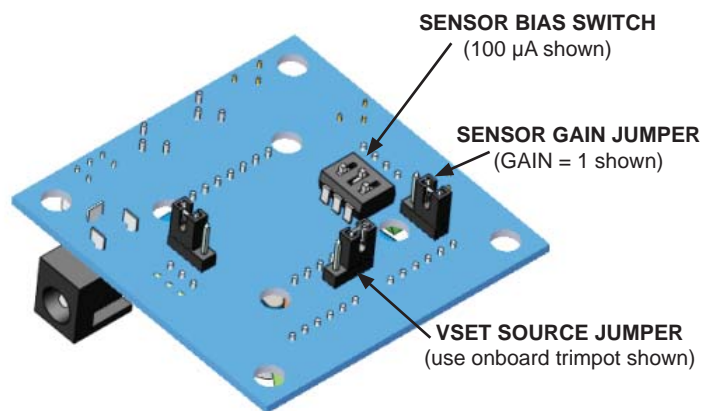

Figure 8. Sensor Bias Switch & VSET Jumper Location

Table 4. Sensor Dipswitch Configuration

SENSOR TYPE	1 mA	100 µA	10 µA	
0 to 2.5 kΩ Thermistor (with Sensor Gain = 10)	OFF	ON	OFF	
2.5 kΩ to 25 kΩ Thermistor	OFF	ON	OFF	
25 kΩ to 250 kΩ Thermistor	OFF	OFF	ON	
100 Ω Platinum RTD	ON	OFF	OFF	
LM335 (with Sensor Gain = 10)	ON	OFF	OFF	
AD590 (See sensor-specific wiring diagram)	OFF	OFF	OFF	

Black indicates switch head position.

SET THE SENSOR GAIN JUMPER

The Sensor Gain Jumper allows the user to amplify sensor voltage. The minimum recommended signal is 250 mV in order to meet published specifications. **Figure 8** shows the jumper location and **Figure 9** shows the jumper position.

- If the sensor voltage is in the acceptable range, use the 1X position and the sensor signal will pass through without amplification.
- If the sensor voltage is very low, such as when using a low resistance thermistor (< 2.5 kΩ) or RTD (100 Ω), move the jumper to the 10X position to amplify the sensor feedback signal by a factor of ten.
- Sensor signal at SEN+ (TB4) should not exceed $V_{DD} - 2V$.



Figure 9. Sensor Gain Jumper Settings

SET THE PROPORTIONAL GAIN AND INTEGRATOR TIME CONSTANT

NOTE: This step must be done without the WTC3243 installed to allow for accurate resistance readings. The Proportional Gain (P GAIN) and Integrator Time Constant (I TERM) can be adjusted during operation, but resistance readings will not match the table if the WTC3243 is installed.

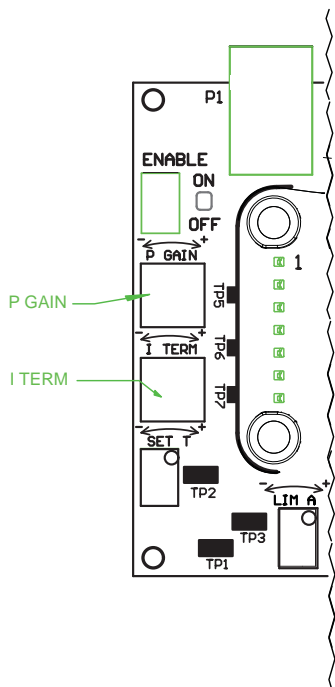

Figure 10. Location of the P GAIN and I TERM Trimpots

Table 5 suggests starting points for P GAIN and I TERM depending on your sensor type. To optimize control, refer to Tech Note [TN-TC01: Optimizing Thermoelectric Control Systems](#).

Table 5. Proportional Gain and Integrator Time Constant Starting Suggestions

SENSOR TYPE	P GAIN (A / V)	P GAIN TRIMPOT RESISTANCE (R _p) TP5 & TP6	I TIME CONSTANT (I _{TC})	I TERM TRIMPOT RESISTANCE (R _i) TP6 & TP7
Thermistor	10	11.1 kΩ	3 seconds	21.4 kΩ
100 Ω Platinum RTD	50	100 kΩ	1 second	120 kΩ
LM335	25	33.3 kΩ	2 seconds	35.9 kΩ
AD590 (Attach a 10 kΩ resistor across Sen+ and Sen-)	25	33.3 kΩ	2 seconds	35.9 kΩ

To adjust the P GAIN, use an ohmmeter to measure resistance between Test Points 5 and 6 (TP5 & TP6).

Adjust the P GAIN trimpot to the desired resistance; see **Table 5** for suggested starting points. An online design calculator is available to assist in determining resistance values.

<http://www.teamwavelength.com/support/calculator/wtc/default.php>

Or use **Equation 1** to calculate the P GAIN trimpot resistance.

Equation 1. Calculating R_p from P GAIN

$$R_p = \left(\frac{100,000}{\frac{100}{PGAIN} - 1} \right) [\Omega]$$

Equation 2. Calculating P GAIN from R_p

$$PGAIN = \left(\frac{100}{\frac{100,000}{R_p} + 1} \right) [A / V]$$

Where:

- R_p is in Ohms (Ω)
- PGAIN is in Amps / Volts (A / V)

To adjust the I TERM, use an ohmmeter to measure resistance between Test Points 6 & 7 (TP6 & TP7).

Adjust the I TERM trimpot to the desired resistance, see **Table 5** for suggested starting points. An online design calculator is available to assist in determining resistance values.

<http://www.teamwavelength.com/support/calculator/wtc/default.php>

Or use **Equation 3** to calculate the I TERM trimpot resistance. **Equation 4** shows how to calculate the I TERM, given the trimpot resistance.

Equation 3. Calculating R_I from I_{TC}

$$R_I = \left(\frac{100,000}{(1.89) I_{TC} - 1} \right) [\Omega]$$

Equation 4. Calculating I_{TC} from R_I

$$I_{TC} = (0.53) \left(\frac{100,000}{R_I} + 1 \right) [\text{Seconds}]$$

Where:

R_I is in Ohms (Ω)

I_{TC} is in seconds

INSTALL THE WTC3243 ON THE WTC3293 EVALUATION BOARD



THE NOTCH AT THE TOP OF THE WTC3243 MUST BE ORIENTED AT THE TOP OF THE PRINTED CIRCUIT BOARD (PCB). THIS ORIENTATION PLACES PIN 1 IN THE UPPER LEFT CORNER. SEE **FIGURE 11** BELOW FOR PROPER ORIENTATION.

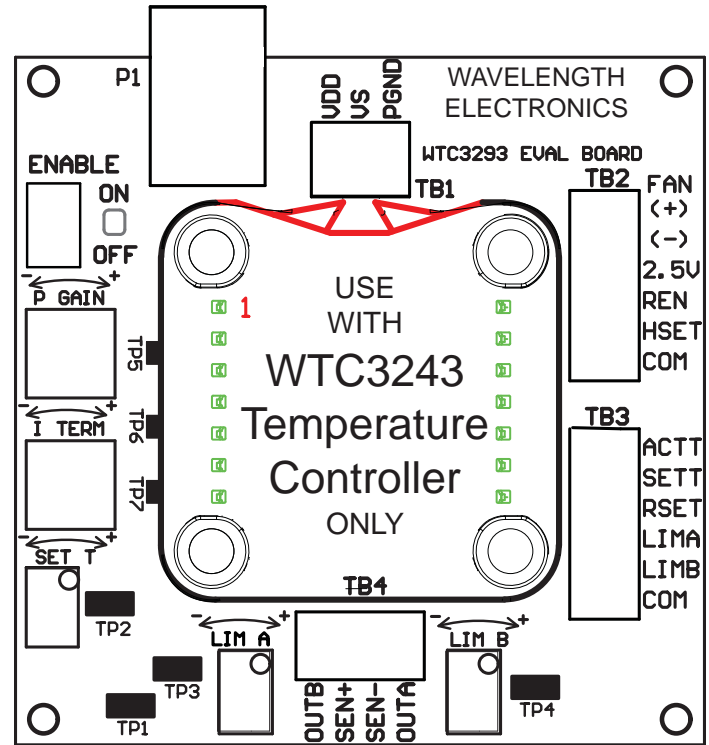

Figure 11. WTC3243 Installed on WTC3293 Eval Board

1. Match up the notch on the WTC3243 with the silkscreen on the PCB.
2. Align the pins with the sockets, ensuring that all pins are lined up in their respective sockets.
3. Press firmly to seat the WTC3243. **Make sure that none of the pins were bent during insertion before continuing.**
4. The pins alone do not provide sufficient mechanical strength to secure the WTC to the circuit board. Install two 4-40x3/8" screws from the bottom of the PCB into the WTC3243 heat spreader. Choose opposite corners that will not interfere with fan mounting.
5. Attach the snap-in standoffs. See **Figure 12. WTC3293 Standoff Positioning on page 16.**

Follow **Figure 13** to assemble the heatsink and fan to the temperature controller.

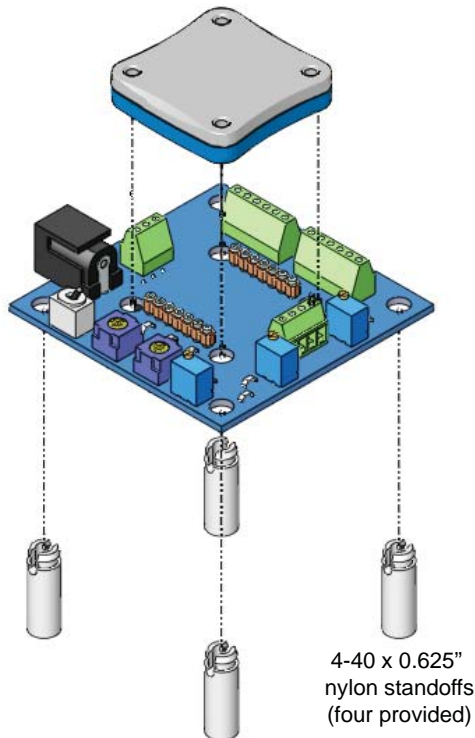

Figure 12. WTC3293 Standoff Positioning

ATTACH THE HEATSINK & FAN

The WTC3243 is designed to handle currents as high as 2.2 A and installing a heatsink and fan is optional when using less than +5 V or 500 mA during operation. A heatsink and/or fan is mandatory when driving currents higher than 500 mA or operating above +5 V.

Refer to the online SOA calculator to determine the Safe Operating Area and proper thermal solution for your application. Wavelength's temperature controller SOA calculator is found here:

<http://www.teamwavelength.com/support/calculator/soa/soatc.php>

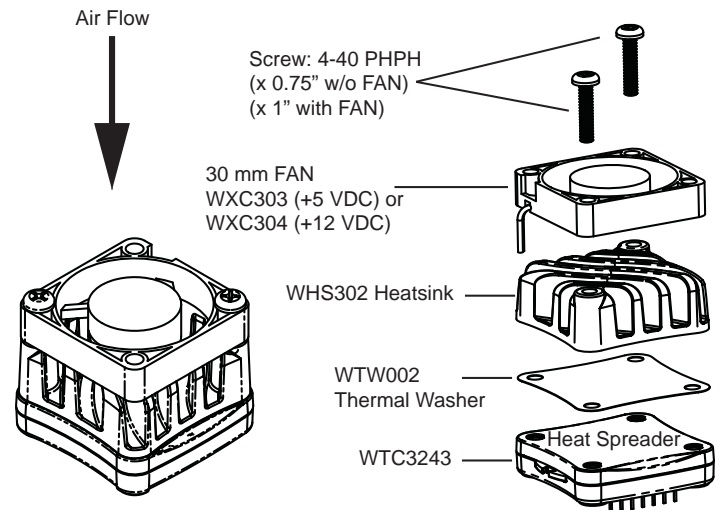

Actual fan wire configuration may be different than shown.

Fan can be rotated on the WTC so the location of the wires matches your PCB.

Figure 13. Attaching the WEV Thermal Components

Clean all of the mating surfaces on the WTC electronics component and heatsink. It is important that no particulates or foreign matter are on either surface.

Attach the adhesive side of the thermal washer to the bottom of the heatsink, aligning the washer holes with the heatsink holes.

If a fan is required, align the fan with the heatsink. The direction of air flow, as indicated on the fan, is into the heatsink.

Attach the heatsink and fan assembly to the temperature controller heat spreader, using two screws.

Connect the fan leads to Terminal Block 2 (TB2), securing with a small flat head screwdriver. The red wire connects to FAN (+) and the black wire to FAN (-).

The fan connects to the V_{DD} supply, not V_S , so be sure that the correct voltage fan is selected, either +5 VDC or +12 VDC.

ATTACH THE VDD AND VS POWER SUPPLIES

The V_{DD} power supply is used to power the WTC3243 internal control electronics and must be capable of sourcing a minimum of 8 mA of current. If a fan is needed, the fan draw current on V_{DD} will also need to be added to the minimum required current. The V_S power supply is used to power the WTC3243 output stage and must be capable of supplying a current greater than the Limit A (LIMA) and Limit B (LIMB) current limit settings.

For simple operation, set the Power Supply Jumper to “1” or Single Supply Operation (see **Figure 6**) and then use the power jack. The power jack is tied to V_{DD} . To separate the supplies, set the Power Jumper to “2” or Dual Supply Operation and use either the terminal block (TB1) alone or a combination of the power jack and VS on TB1.

Use PGND for the power return. The common (COM) terminal on the WTC3293 is not intended to act as a power connection, but as a low noise ground reference for monitor signals.

A separate power supply allows the output stage to operate at a voltage lower than the V_{DD} supply or up to the +30 V maximum. Select V_S approximately 1.0 Volt above the maximum voltage drop across Output A (OUTA) and Output B (OUTB), which is also the voltage across the thermoelectric controller, to reduce the power dissipation on the WTC3243 component and minimize the heatsinking requirements. When sizing the power supply, take the temperature controller, load, and heatsink components into consideration.

The 2.5 mm input power jack is attached to V_{DD} . You can use the Wavelength PWRPAK power supplies with this jack. Use either the power jack or the power inputs on TB1, not both.



THE COMMON (COM) TERMINAL ON THE WTC3293 IS NOT INTENDED TO ACT AS A POWER CONNECTION, BUT AS A LOW NOISE GROUND REFERENCE FOR MONITOR SIGNALS.



ONCE POWER IS CONNECTED TO THE EVALUATION BOARD, ALL CONTROL ELECTRONICS ARE POWERED, HOWEVER THERE IS NO DRIVE CURRENT AVAILABLE TO OTHER COMPONENTS UNTIL THE WTC3293 ENABLE SWITCH IS ON.

CONFIGURE THE HEAT AND COOL LIMITS

The WTC3293 Limit A (LIMA) and Limit B (LIMB) trimpots independently adjust the heat and cool current limits from zero to a full 2.2 A.

Use **Equation 5** to calculate the voltage at LIMA or LIMB corresponding to the desired limit current (I_{LIM}).

Equation 5. Calculating LIMA or LIMB from I_{LIM}

$$LIM = (0.3 * I_{LIM}) + 1$$

Where:

LIMA or LIMB is in Volts (V)

I_{LIM} is the desired maximum output current, in Amps (A)

Once the LIMA and LIMB values are determined, toggle the ENABLE to ON to apply power to V_{DD} and V_S (no load required). Rotate LIMA or LIMB trimpot and monitor the respective voltage at LIMA and LIMB on TB3. Use COM as ground reference. Turn the trimpots counter-clockwise to reduce the limits or clockwise to increase them.

Use **Table 6** to determine which limit trimpot sets the heating and cooling limits based on the sensor and load type.

Table 6. LIMA and LIMB Current Limit Trimpot Function

SENSOR TYPE	LOAD TYPE	LIMA TRIMPOT	LIMB TRIMPOT
Thermistor	Thermoelectric	Cool Current Limit	Heat Current Limit
100 Ω Platinum RTD, LM335, AD590	Thermoelectric	Heat Current Limit	Cool Current Limit
Thermistor	Resistive Heater	Turn Fully CCW	Heat Current Limit
100 Ω Platinum RTD, LM335, AD590	Resistive Heater	Heat Current Limit	Turn Fully CCW

CONNECT THE TEMPERATURE SENSOR AND THERMAL LOAD OR A TEST LOAD

With the ENABLE switch set to OFF (output is disabled), connect the load (the thermoelectric cooler or resistive heater) to the outputs (OUTA or OUTB). Use **Table 6** to determine the connections to the outputs.

Table 7. OUTA & OUTB Wiring Configuration

SENSOR TYPE	LOAD TYPE	OUTPUT A (OUTA)	OUTPUT B (OUTB)
NTC Thermistor	Thermoelectric	Negative TEC Terminal	Positive TEC Terminal
100 Ω Platinum RTD, LM335, AD590	Thermoelectric	Positive TEC Terminal	Negative TEC Terminal
NTC Thermistor	Resistive Heater	Quick Connection: Connect the resistive heater to OUTA and OUTB. Adjust the cooling current limit to zero by turning the LIMA trimpot fully CCW. Maximum Voltage Connection: Connect one side of the heater to OUTB and the other to the voltage source V_s .	
100 Ω Platinum RTD, LM335, AD590	Resistive Heater	Quick Connection: Connect the resistive heater to OUTA and OUTB. Adjust the cooling current limit to zero by turning the LIMB trimpot fully CCW. Maximum Voltage Connection: Connect one side of the heater to OUTA and the other to the voltage source V_s .	

Resistive temperature sensors and LM335 type temperature sensors should connect their negative termination directly to Pin 13 (GND) to avoid parasitic resistances and voltages affecting temperature stability and accuracy.

Connect thermistors and RTD sensors, which are not polarized, to SEN+ and SEN- on Terminal Block 4 (TB4). Connect LM335 and AD590, which are polarized, as shown below.

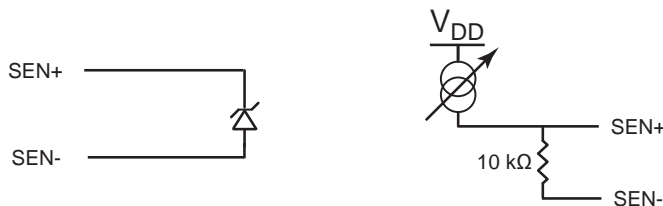

Figure 14. Connecting IC Temperature Sensors

MONITOR THE SETPOINT TEMPERATURE AND ACTUAL TEMPERATURE SENSOR VOLTAGE

Terminal Block 3 (TB3) includes three lines for externally monitoring the WTC3243 temperature setpoint voltage (SET T) and the actual temperature sensor voltage levels (ACT T). Both the SET T and ACT T voltages are measured from the COMMON (COM) terminal.

Convert the monitor voltages to sensor resistance for thermistors and RTDs, and to temperature for LM335s and AD590s using the following equations.

Table 8. Converting the SET T and ACT T Monitor Voltages

SENSOR TYPE	VOLTAGE CONVERSION
Thermistor	$R = \left(\frac{\text{Voltage}^*}{\text{Sensor Bias Current}} \right) [\Omega]$
100 Ω Platinum RTD (where Sensor Gain is 10)	$R = \left(\frac{\text{Voltage}^*}{\text{Sensor Bias Current}} \right) / 10 [\Omega]$
LM335 or AD590	$T = (\text{Voltage}^* - 2.7315) * 100 [^{\circ}\text{C}]$

* Voltage refers to the measurements made from the ACT T or SET T points, in Volts (V). Sensor Bias Current is in Amps (A).

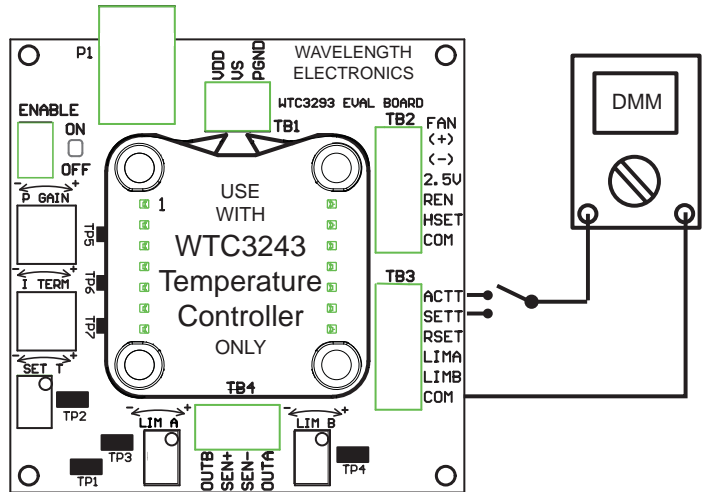

Figure 15. WTC3243 Evaluation Board & Voltmeter

To read the ACT T, attach the voltmeter to the ACT T and COM wires.

To read the SET T, attach the voltmeter to the SET T and COM wires.

ADJUST THE TEMPERATURE SETPOINT VOLTAGE

The setpoint voltage can be adjusted either by using the evaluation board's onboard SET T trimpot or by connecting a remote voltage source or potentiometer to the RSET or HSET inputs. Only one of these setpoints can be used. When controlling correctly, the SET T matches the ACT T at the desired temperature.

The setpoint voltage can also be adjusted using the evaluation board by connecting a remote voltage source or potentiometer to the remote setpoint (RSET) or the high voltage setpoint (HSET) inputs.

To adjust the SET T, with the voltmeter attached to the SET T and COM wires, turn the SET T trimpot screw. Rotate the trimpot clockwise to increase or counter-clockwise to decrease the voltage. The SET T trimpot can be adjusted from 0 V to 5 V. To get above 4.5 V, increase V_{DD} to a minimum of 5.5 V. To read the actual temperature and setpoint temperature of the device, the power needs to be connected.

NOTE: If you are not getting a setpoint reading, make sure your VSET jumper is set correctly.

- The RSET input is subject to the Data Acquisition (DAQ) Failsafe Protection circuit. If RSET drops below 0.3 V, the setpoint will be overridden and set to 1 V. See the **Additional Technical Notes** section for changing these defaults. RSET is limited to 0 to 6.5 V.
- The HSET remote setpoint input is not subject to the DAQ Failsafe Protection circuit. It is limited to 0 to ($V_{DD} - 2.5$ V).

ENABLE AND DISABLE THE OUTPUT CURRENT

Toggle the ENABLE switch to ON. Output is enabled when the green LED light is on. If there is no power to V_S , the LED will not light.

With the power connected, an external enable signal to the remote enable (REN) on TB2 can be used.

0 V = ENABLE
Floating or >3 V = DISABLED

The onboard switch overrides the external signal.

DESIGN GUIDE – WTC3243

NECESSARY EQUIPMENT

The following equipment is the minimum necessary to configure the WTC3243 for basic operation.

- WTC3243 Thermoelectric Controller
- Digital multimeter, 4-1/2 digit resolution recommended
- Custom Printed Circuit Board (PCB)
- Thermistor or other temperature sensor
- Peltier-type thermoelectric module or resistive heater
- Power supply or supplies
- Source for external setpoint (signal generator, trimpot circuit, etc.)
- 5 to 6 Resistors for Limits (2), P GAIN, Integrator Time Constant, Sensor Bias Current, Sensor Gain (optional)
- Thermal Solutions Kit, if operating above 5 V or 500 mA

SAFE OPERATING AREA AND THERMAL DESIGN CONSIDERATIONS

SOA charts are included in this datasheet for quick reference, but we recommend you use the online tools instead. Refer to the SOA calculator for the WTC3243.

<http://www.teamwavelength.com/support/calculator/soa/soatc.php>



TO ENSURE SAFE OPERATION OF THE WTC3243 CONTROLLER, IT IS IMPERATIVE THAT YOU DETERMINE IF THE UNIT IS GOING TO BE OPERATING WITHIN THE INTERNAL HEAT DISSIPATION SAFE OPERATING AREA (SOA).

DESIGN CONSIDERATIONS WHEN USING THE WTC3243 WITHOUT THE WTC3293 BOARD

The WTC3243 Thermoelectric Controller is designed to be integrated into any custom printed circuit board (PCB) using the following design specifications.

The following equations for resistors are incorporated in the WTC3243 Circuit Design Calculator online at:

<http://www.teamwavelength.com/support/calculator/wtc/default.php>

Wiring diagrams for various load configurations are shown on the subsequent pages. Equations from the calculator follow the wiring diagrams.

OPERATING WITH THERMISTOR TEMPERATURE SENSORS

A thermistor sensor has the best sensitivity, very small size, a temperature range of -80° to +150° C, but poor linearity.

Thermistor temperature sensors should connect one terminal as close as possible to GND (Pin 13) to avoid parasitic resistances and voltages affecting temperature stability and accuracy.

The diagrams on this page demonstrate how to configure the WTC3243 for operation with a thermistor temperature sensor. An online calculation utility to determine resistances is available at:

<http://www.teamwavelength.com/support/calculator/wtc/default.php>.

QUICK CONNECT LEGEND	
DIAGRAM REFERENCE	TABLE OR EQUATION
R_{LIMA}	Table 9 on page 25
R_{LIMB}	Table 9 on page 25
R_p	Table 11 on page 27
R_i	Table 12 on page 27
R_{BIAS}	Table 10 on page 26 Equation 6 & Equation 7
R_T	Thermistor datasheet
R_G	N/A

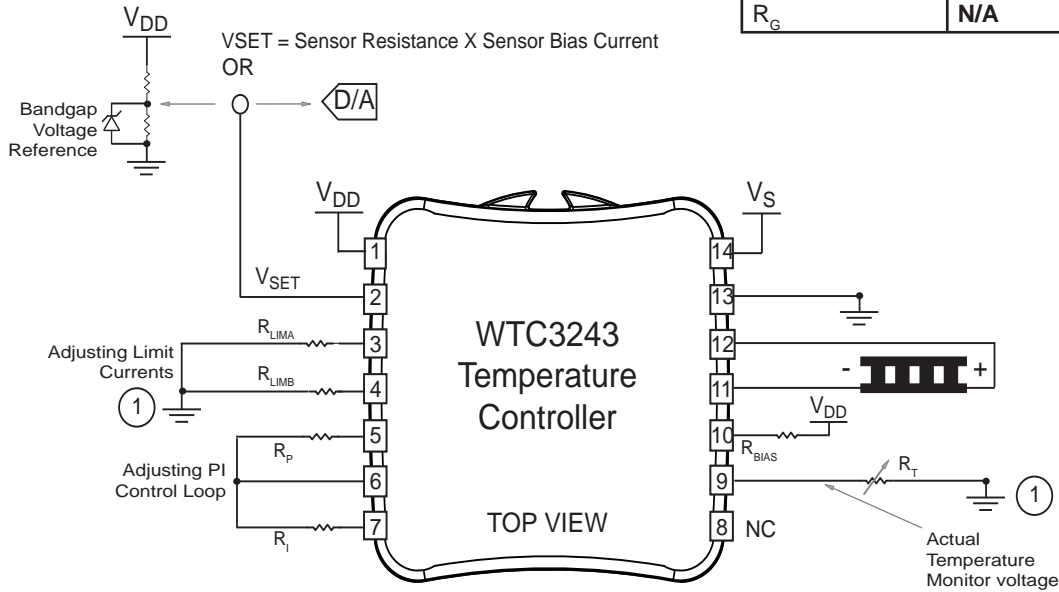

① TIE GROUND CONNECTIONS DIRECTLY TO PIN 13

Figure 16. Thermistor / TEC Operation -- Top View

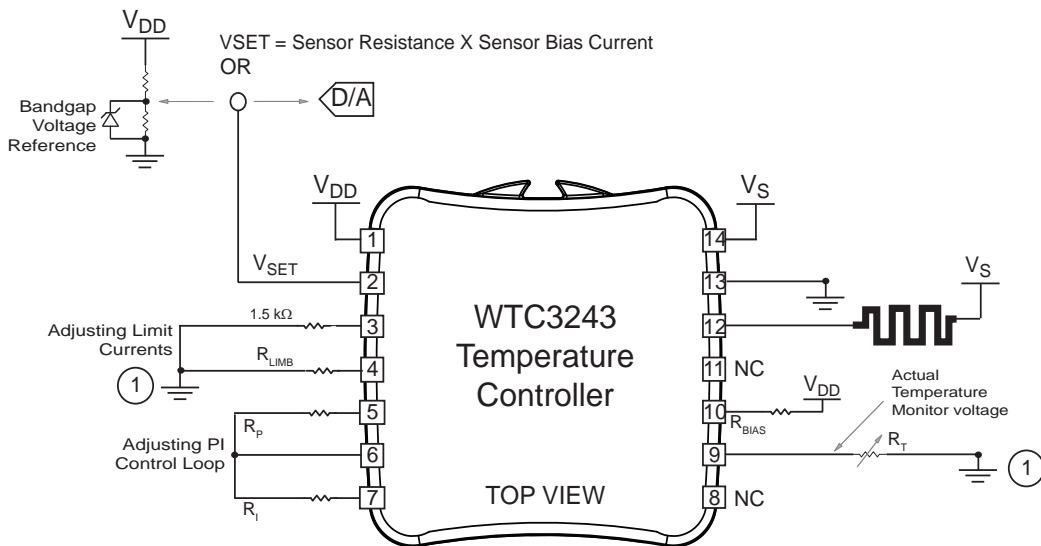

① TIE GROUND CONNECTIONS DIRECTLY TO PIN 13

Figure 17. Thermistor / Resistive Heater Operation -- Top View

IF YOU ARE UPGRADING FROM THE WHY5640: The position of Pin 1 on the WHY5640 is reversed (or mirrored) relative to the position of Pin 1 on the WTC3243.

OPERATING WITH RTD TEMPERATURE SENSORS

An RTD sensor has good linearity, relatively small size, a temperature range of -260° to +850° C, but poor sensitivity.

Resistive temperature sensors should connect one terminal as close as possible to GND (Pin 13) to avoid parasitic resistances and voltages affecting temperature stability and accuracy.

The diagrams on this page demonstrate how to configure the WTC3243 for operation with a Platinum RTD temperature sensor. An online calculation utility to determine resistances is available at: <http://www.teamwavelength.com/support/calculator/wtc/default.php>.

QUICK CONNECT LEGEND	
DIAGRAM REFERENCE	TABLE OR EQUATION
R_{LIMA}	Table 9 on page 25
R_{LIMB}	Table 9 on page 25
R_p	Table 11 on page 27
R_i	Table 12 on page 27
R_{BIAS}	Table 10 on page 26 Equation 6 & Equation 7
R_T	Sensor datasheet
R_G	Table 10 on page 26 Equation 8

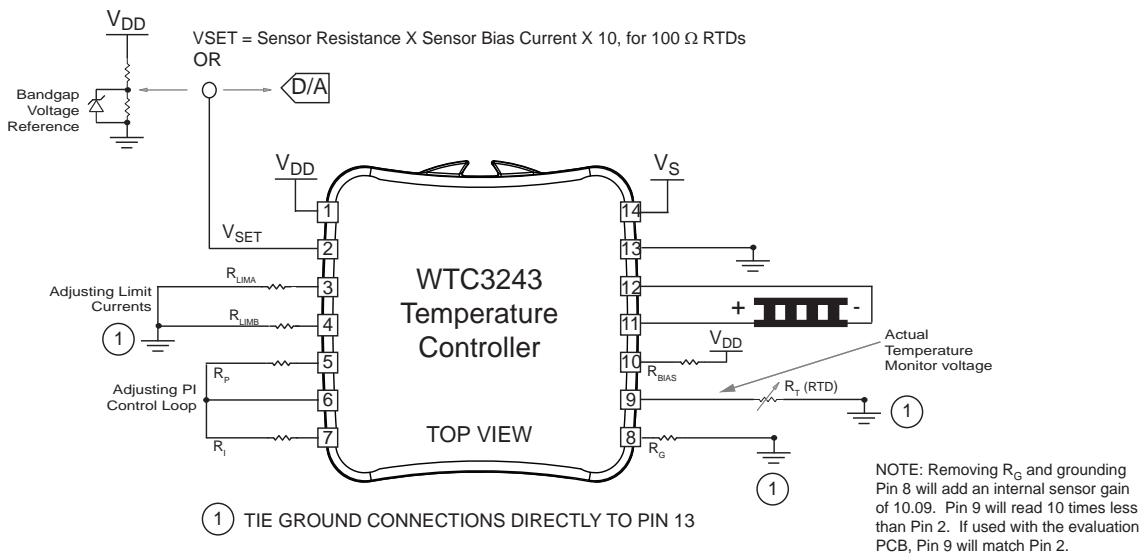

Figure 18. RTD / Thermoelectric Operation -- Top View

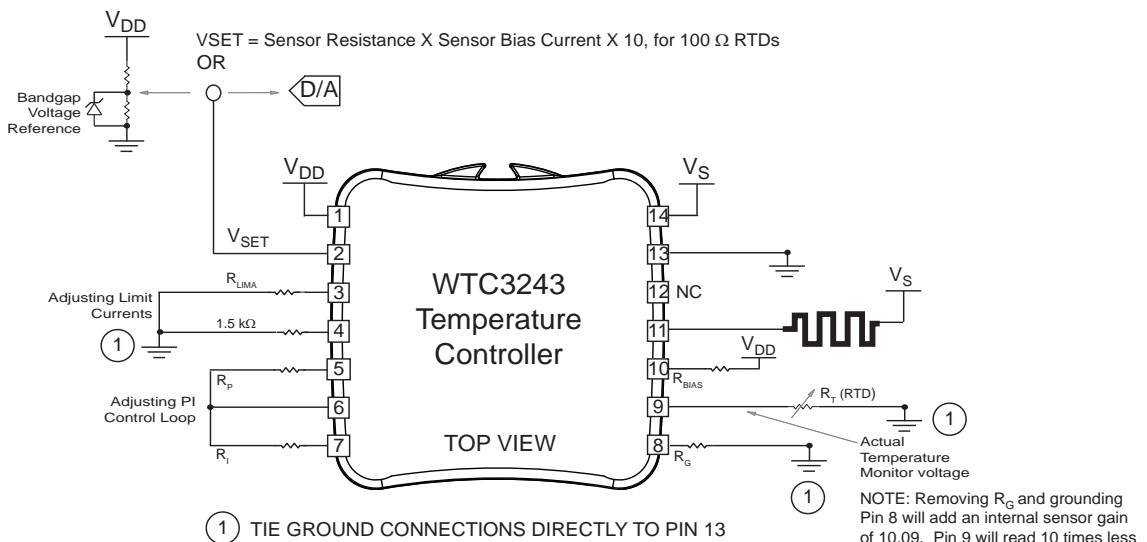

Figure 19. RTD / Resistive Heater Operation -- Top View

IF YOU ARE UPGRADING FROM THE WHY5640: The position of Pin 1 on the WHY5640 is reversed (or mirrored) relative to the position of Pin 1 on the WTC3243.

OPERATING WITH LM335 TYPE TEMPERATURE SENSORS

LM335 temperature sensors have the best linearity, good sensitivity, a temperature range of -40° to +100° C, but are large in size.

LM335 type temperature sensors should connect their negative termination directly to Pin 13 (GND) to avoid parasitic resistances and voltages affecting temperature stability and accuracy.

The following diagrams demonstrate how to configure the WTC3243 for operation with a National Semiconductor LM335 temperature sensor. An online calculation utility to determine resistances is available at: <http://www.teamwavelength.com/support/calculator/wtc/default.php>.

QUICK CONNECT LEGEND	
DIAGRAM REFERENCE	TABLE OR EQUATION
R _{LIMA}	Table 9 on page 25
R _{LIMB}	Table 9 on page 25
R _P	Table 11 on page 27
R _I	Table 12 on page 27
R _{BIAS}	Table 10 on page 26 Equation 7
R _T	Sensor datasheet
R _G	N/A

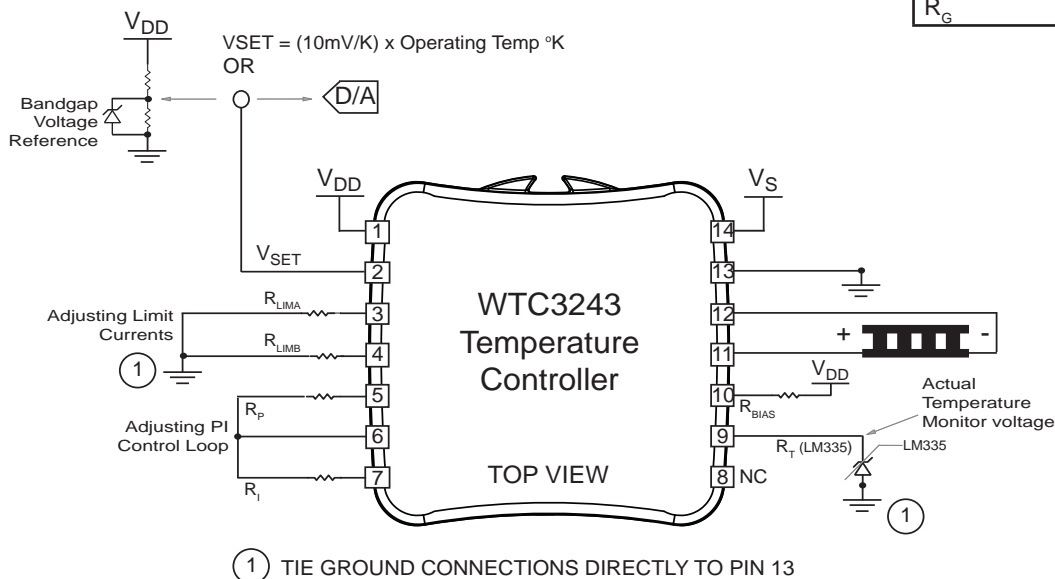

Figure 20. LM335 / Thermoelectric Operation -- Top View

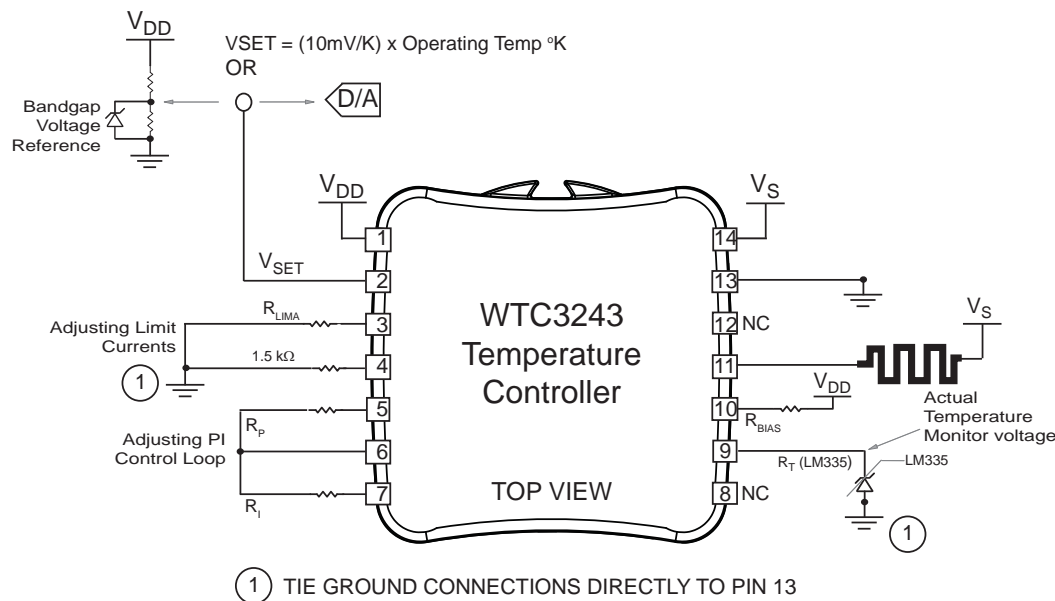

Figure 21. LM335 / Resistive Heater Operation -- Top View

IF YOU ARE UPGRADING FROM THE WHY5640: The position of Pin 1 on the WHY5640 is reversed (or mirrored) relative to the position of Pin 1 on the WTC3243.

OPERATING WITH AD590 TYPE TEMPERATURE SENSORS

AD590 type temperature sensors have the best linearity, good sensitivity, a temperature range of -20° to +105° C, but are larger in size. Operation requires that V_{DD} be +8 V or greater.

The following diagrams demonstrate how to configure the WTC3243 for operation with an Analog Devices AD590 Temperature Sensor. An online calculation utility to determine resistances is available at:

<http://www.teamwavelength.com/support/calculator/wtc/default.php>.

QUICK CONNECT LEGEND	
DIAGRAM REFERENCE	TABLE OR EQUATION
R_{LIMA}	Table 9 on page 25
R_{LIMB}	Table 9 on page 25
R_P	Table 11 on page 27
R_I	Table 12 on page 27
R_{BIAS}	N/A
R_T	Sensor datasheet
R_G	N/A

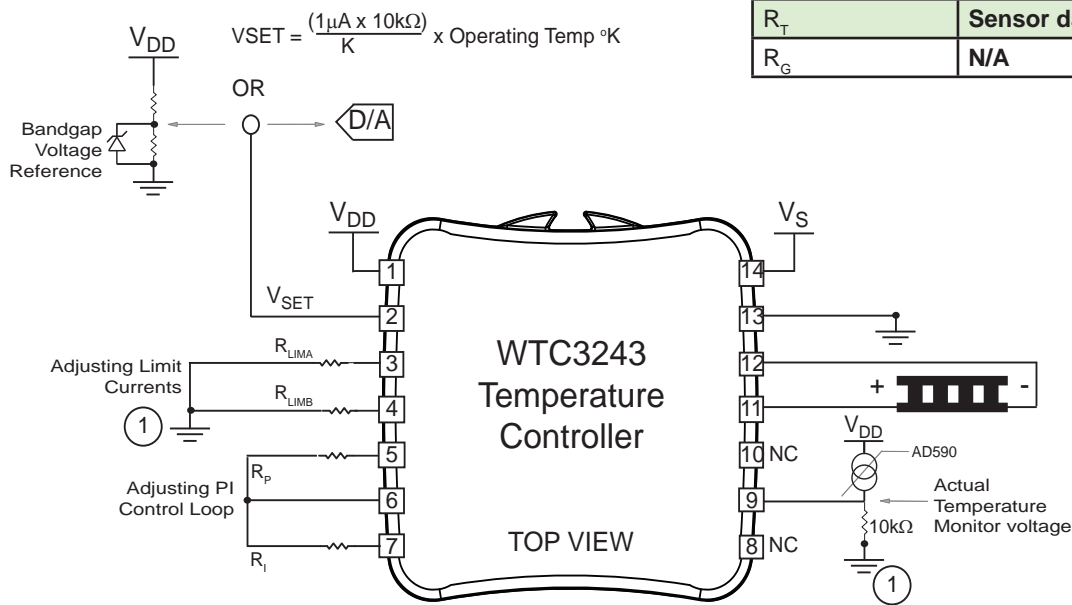

① TIE GROUND CONNECTIONS DIRECTLY TO PIN 13

Figure 22. AD590 / Thermoelectric Operation -- Top View

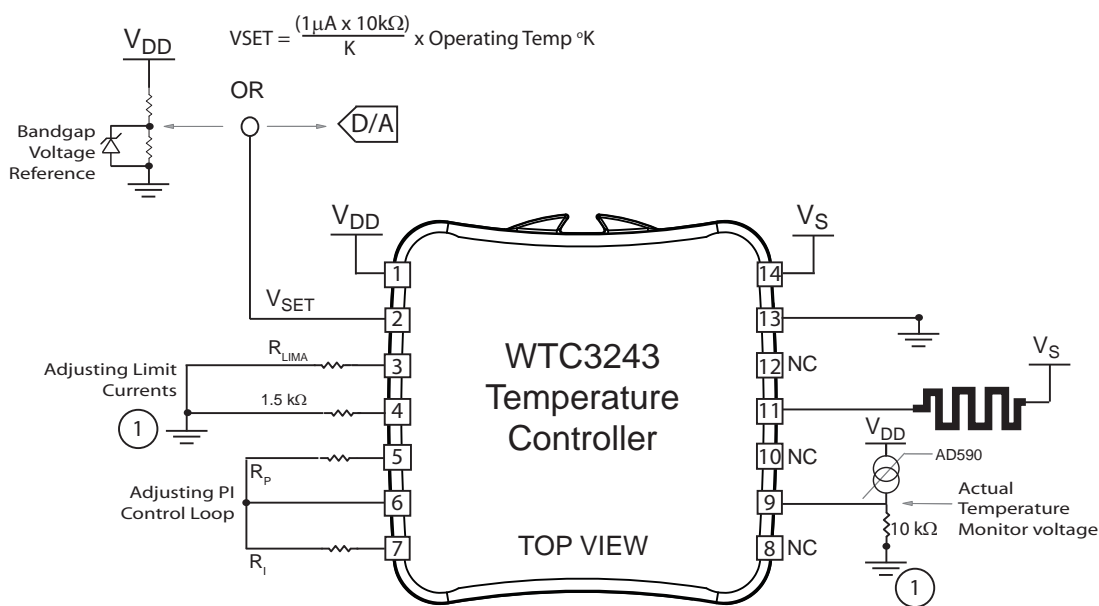

① TIE GROUND CONNECTIONS DIRECTLY TO PIN 13

Figure 23. AD590 / Resistive Heater Operation -- Top View

IF YOU ARE UPGRADING FROM THE WHY5640: The position of Pin 1 on the WHY5640 is reversed (or mirrored) relative to the position of Pin 1 on the WTC3243.

CHOOSE THE HEATING AND COOLING CURRENT LIMIT RESISTORS – R_A & R_B

Use **Table 9** to select appropriate resistor values for R_A and R_B . The Heat and Cool Current Limits graph, **Figure 24**, shows the range of error for **Table 9**.

Table 9. Maximum Output Current vs. Current Limit Resistor

MAXIMUM OUTPUT CURRENT (A)	CURRENT LIMIT RESISTOR (k Ω) R_A or R_B
0.0	1.58
0.1	1.66
0.2	1.74
0.3	1.83
0.4	1.92
0.5	2.01
0.6	2.11
0.7	2.22
0.8	2.33
0.9	2.45
1.0	2.58
1.1	2.71
1.2	2.86
1.3	3.01
1.4	3.18
1.5	3.36
1.6	3.55
1.7	3.76
1.8	3.98
1.9	4.23
2.0	4.50
2.1	4.79
2.2	5.11

Figure 25 shows fixed heating and cooling limits and is the standard implementation.

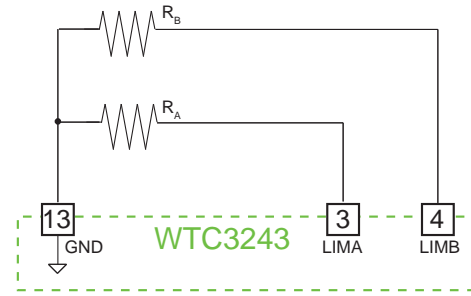

Figure 25. Fixed Heat and Cool Current Limits

Figure 26 diagrams setting current limits independently using trim pots. The 5 k Ω single turn trim pots shown adjust the maximum output currents from 0 to 2.2 A.

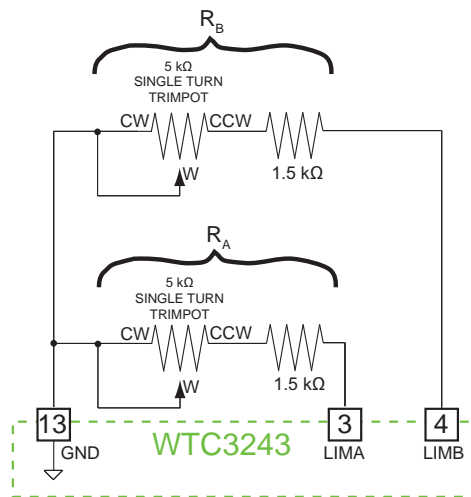

Figure 26. Adjustable Heat and Cool Current Limits

APPROXIMATE VALUE OF CURRENT LIMIT RESISTOR R_c vs MAXIMUM OUTPUT CURRENT

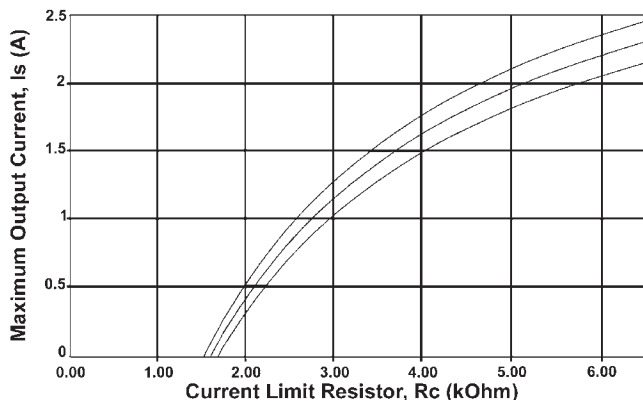

Figure 24. Max Output Current Limits

DISABLING THE OUTPUT CURRENT

The output current can be enabled and disabled, as shown in **Figure 27**, using a Double Pole–Single Throw (DPST) switch. In the following example, the effective limit resistance is 3 k Ω or 1.3 A.

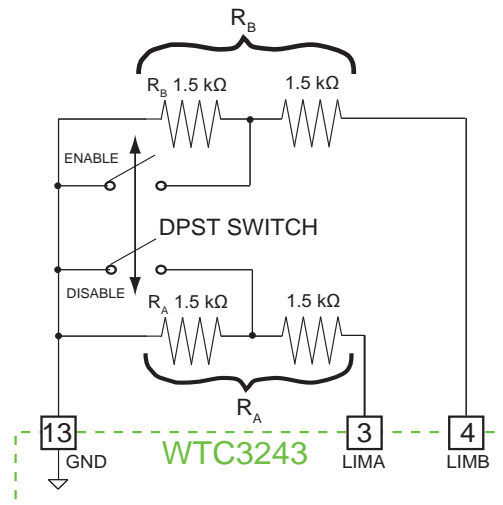

Figure 27. Disabling the Output Current

RESISTIVE HEATER TEMPERATURE CONTROL

The WTC3243 can operate resistive heaters by disabling the cooling output current. When using Resistive Heaters with NTC thermistors, connect LIMA (Pin 3) to GND (Pin 13) with a 1.5 kΩ resistor.

Connect LIMB (Pin 4) to GND (Pin 13) with a 1.5 kΩ resistor when using RTDs, LM335 type, and AD590 type temperature sensors with a resistive heater.

DETERMINE I_{BIAS}

The resistance of your sensor in conjunction with the sensor bias current must produce a setpoint voltage between 0.25 V and ($V_{DD} - 2$ V) in order to be used in the control loop. **Equation 6** shows the relationship.

- Connect a resistor R_{BIAS} between BIAS (Pin 10) and V_{DD} (Pin 1) to set the sensor bias current.
- The LM335 always uses a 10 mA bias current (see **Table 8** for conversion equation).

Equation 6. Calculating I_{BIAS}

$$I_{BIAS} = \frac{V_{SET}}{\text{Sensor Resistance}}$$

SET THE SENSOR BIAS CURRENT AND SENSOR GAIN RESISTORS

Table 10 lists the suggested resistor values for R_{BIAS} and R_G for various sensors and resistance values.

Equation 7 demonstrates how to calculate a value of R_{BIAS} given a desired sensor bias current, I_{BIAS} .

Equation 7. Calculating R_{BIAS}

$$R_{BIAS} = \frac{2}{I_{BIAS}} \quad [\Omega]$$

Table 10. Resistor Value and Resistance Range

SENSOR TYPE	I_{BIAS}	R_{BIAS}	SENSOR GAIN	R_G
2.252 kΩ Thermistor	1 mA	2 kΩ	1	Open
5 kΩ Thermistor	200 μA	10 kΩ	1	Open
10 kΩ Thermistor	100 μA	20 kΩ	1	Open
20 kΩ Thermistor	50 μA	40 kΩ	1	Open
50 kΩ Thermistor	20 μA	100 kΩ	1	Open
100 kΩ Thermistor	10 μA	200 kΩ	1	Open
500 kΩ Thermistor	2 μA	1 MΩ	1	Open
100 Ω Platinum RTD	1 mA	2 kΩ	10	Short or 100 Ω *
1 kΩ Platinum RTD	1 mA	2 kΩ	1	Open
LM335	1 mA	2 kΩ	1	Open
R_{GAIN}				
AD590	10 kΩ	Open	1	Open
* Sensor Gain with 100 Ω is exactly 10. Sensor Gain shorted is 10.09.				

When using RTDs, signal can be very low. The sensor signal applied to S+ (Pin 9) can be amplified up to a factor of 10 by inserting a resistor, R_G , between SG (Pin 8) and GND (Pin 13). Connect SG (Pin 8) directly to GND (Pin 13) for a sensor gain of 10.09. The lower the value of R_G , the more gain applied to the sensor signal.

Equation 8 demonstrates how to calculate a value for R_G given a desired sensor gain.

Equation 8. Calculating R_G

$$R_G = \left(\frac{90,900}{(G_{SENSOR} - 1)} - 10,000 \right) \quad [\Omega]$$

SET THE CONTROL LOOP PROPORTIONAL GAIN RESISTOR

The control loop Proportional Gain can be set by inserting a resistor, R_p , between PGAIN (Pin 5) and +1V (Pin 6) to set PGAIN from 1 to 100.

Table 11 lists the suggested resistor values for R_p versus sensor type and the ability of the thermal load to change temperature rapidly.

Table 11. Proportional Gain Resistor R_p vs. Sensor Type and Thermal Load Speed

PROPORTIONAL GAIN RESISTOR R_p	PROPORTIONAL GAIN (A / V)	SENSOR TYPE / THERMAL LOAD SPEED
4.99 k Ω	5	Thermistor / Fast
24.9 k Ω	20	Thermistor / Slow
100 k Ω	50	RTD / Fast
Open	100	RTD / Slow
24.9 k Ω	20	AD590 or LM335 / Fast
100 k Ω	50	AD590 or LM335 / Slow

Use **Equation 9** to calculate R_p from PGAIN.

Equation 9. Calculating R_p from PGAIN

$$R_p = \left(\frac{100,000}{\frac{100}{\text{PGAIN}} - 1} \right) [\Omega]$$

To calculate PGAIN from R_p use **Equation 10**.

Equation 10. Calculating PGAIN from R_p

$$\text{PGAIN} = \left(\frac{100}{\frac{100,000}{R_p} + 1} \right) [A / V]$$

SET THE CONTROL LOOP INTEGRATOR TIME CONSTANT

To set the control loop Integrator Time Constant (I_{TC}), insert a resistor, R_i , between +1V (Pin 6) and I (Pin 7) to set I_{TC} from 0.53 to 4.5 seconds.

Table 12 lists the suggested resistor values for R_i versus sensor type and the ability of the thermal load to change temperature rapidly.

Table 12. Integrator Time Constant vs. Sensor Type and Thermal Load Speed

INTEGRATOR RESISTOR R_i	INTEGRATOR TIME CONSTANT (SECONDS)	SENSOR TYPE / THERMAL LOAD SPEED
21.4 k Ω	3	Thermistor / Fast
13.3 k Ω	4.5	Thermistor / Slow
Open	0.53	RTD / Fast
112 k Ω	1	RTD / Slow
112 k Ω	1	AD590 or LM335 / Fast
13.3 k Ω	4.5	AD590 or LM335 / Slow

Equation 11 demonstrates how to calculate a value for R_i given a desired integrator time constant. The Integrator Time Constant, I_{TC} , is measured in seconds.

Equation 11. Calculating R_i from I_{TC}

$$R_i = \left(\frac{100,000}{(1.89) I_{TC} - 1} \right) [\Omega]$$

Equation 12 demonstrates how to calculate the I_{TC} , given a value for R_i .

Equation 12. Calculating I_{TC} from R_i

$$I_{TC} = (0.53) \left(\frac{100,000}{R_i} + 1 \right) [\text{Seconds}]$$

ADDITIONAL TECHNICAL NOTES

This section includes useful technical information on these topics:

- Connecting an External Potentiometer
- DAQ Protection -- Change Defaults
- Eliminating Trimpots
- Changing the P GAIN to a Fixed Value
- Increasing Proportional Gain Range
- Changing the I TERM to a Fixed Value
- Changing LIM to a Fixed Value
- Changing Onboard Setpoint Trimpot to a Fixed Resistance
- Safe Operating Area & Heatsink Requirements

CONNECTING AN EXTERNAL POTENTIOMETER

RSET: Set the VSET SOURCE jumper in the “X” position (subject to DAQ Failsafe Protection circuit). Place the potentiometer’s CW terminal in the pin marked 2.5 V. Connect the potentiometer’s wiper (W) to the pin marked RSET and CCW terminal to the pin marked COM. Do not use less than 2 kΩ resistance, or the 2.5 V will droop.

HSET: Remove the VSET SOURCE jumper (not subject to DAQ Failsafe Protection circuit). Place the potentiometer’s CW terminal in the pin marked 2.5 V. Connect the potentiometer’s wiper (W) to the pin marked HSET and CCW terminal to the pin marked COM. Do not use less than 2 kΩ resistance, or the 2.5 V will droop.

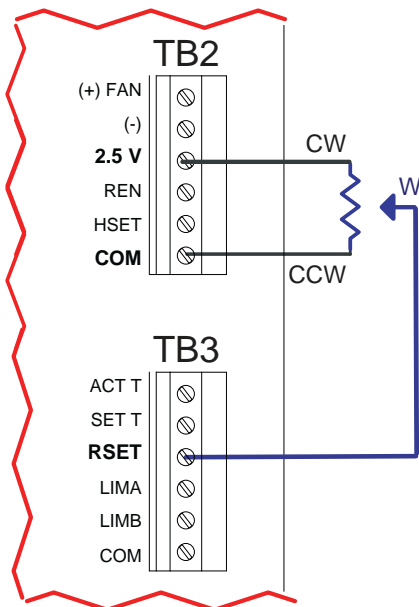

Figure 28. Example Wiring—External RSET Adjustment

DAQ PROTECTION -- CHANGE DEFAULTS

If the voltage set by the external input drops below 0.3 V, the failsafe circuit is triggered and the setpoint defaults to 1 V. This prevents overheating of the load if the input signal fails. The 1 V default is designed for 10 kΩ thermistors (1 V = 25°C). This default is only used with RSET.

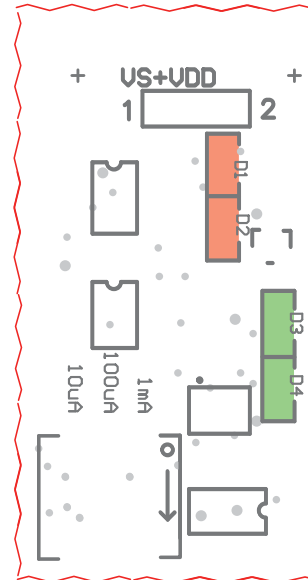

Figure 29. DAC Protection Circuit Settings

To override the failsafe default, remove D1, use the HSET input, or the onboard trimpot. To change the failsafe trip point, change the voltage divider between D1 & D2.

Use **Equation 13** to calculate the appropriate value.

Equation 13. Calculate Failsafe Trip Point Voltage

$$V_{TRIP} = \frac{6.6 D2}{D1 + D2}$$

Where:

D1 default is 100 kΩ.

D2 default is 4.99 kΩ.

D1 should not go below 100 kΩ.

To change the default once tripped, change the voltage divider between D3 & D4. Use **Equation 14** to calculate the appropriate value.

Equation 14. Calculate Failsafe Default Voltage

$$V_{DEFAULT} = \frac{6.6 D4}{D3 + D4}$$

Where:

D3 default is 49.9 kΩ.

D4 default is 9.76 kΩ.

D3 should not go below 49.9 kΩ.

D1, D2, D3, and D4 are 0805 size resistors.

ELIMINATING TRIMPOTS

To simplify set up or to minimize thermal drift, Wavelength recommends that you eliminate trimpots in circuitry. The following details how to use fixed resistances in place of trimpots. Wavelength can load boards at the factory to your specific requirements. Contact Sales to request a Product Variation.

CHANGING THE P GAIN TO A FIXED VALUE

Once the system is optimized:

- Connect an ohmmeter to TP5 & TP6, without the WTC3243 installed.
- Measure the PGAIN trimpot value across pins TP5 & TP6.
- Remove resistor P2.
- Load P1 with a resistor of the value measured (1206 size).

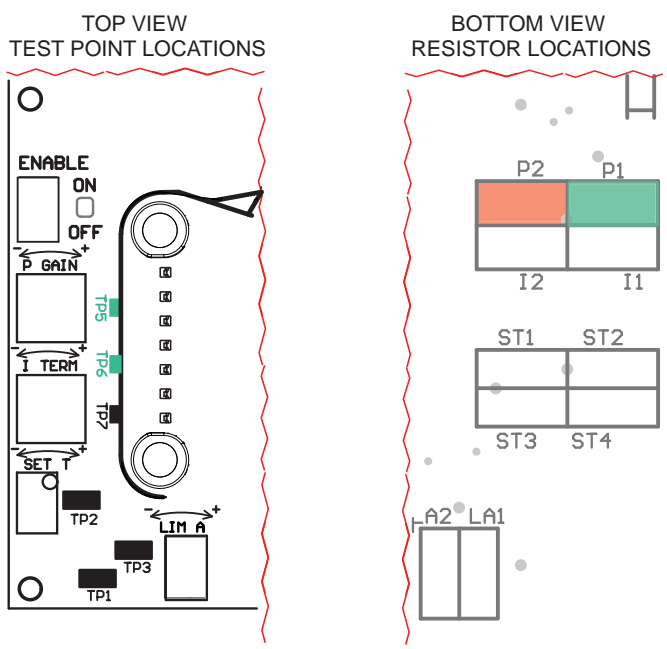

Figure 30. P GAIN Settings

CHANGING THE I TERM TO A FIXED VALUE

Once the system is optimized:

- Connect an ohmmeter to TP6 & TP7, without the WTC3243 installed.
- Measure the I TERM trimpot value across pins TP 6 & TP7.
- Remove resistor I2.
- Load I1 with a resistor of the value measured (1206 size).

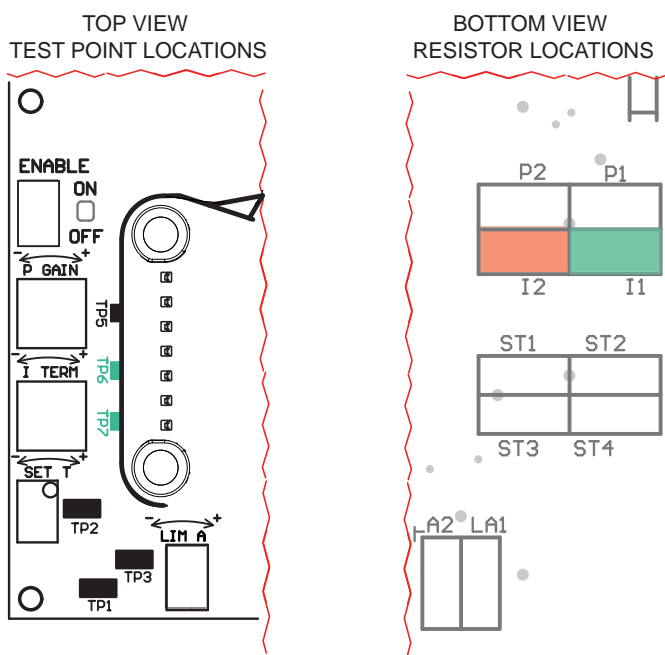

Figure 31. I TERM Setting

INCREASING PROPORTIONAL GAIN RANGE

- Change P2 to a 100 kΩ resistor for P_{MAX} = 75 A / V.
- Remove P2 (in finite resistance) for P_{MAX} = 100 A / V.

CHANGING LIM TO A FIXED VALUE

- Connect an ohmmeter to TP1 & TP3, without the WTC3243 installed.
- Measure the LIMA trimpot value across pins TP1 & TP3.
- Remove resistor LA2.
- Load LA1 with a fixed value to match the trimpot resistance at the proper limit setting (1206 size).
- Repeat with LB2 and LB1 and TP4 & TP1, respectively.

CHANGING ONBOARD SETPOINT TRIMPOT TO A FIXED RESISTANCE

- Connect an ohmmeter to TP1 & TP2, without the WTC3243 installed.
- Measure the SET T trimpot value across pins TP1 & TP2.
- Remove resistors ST3 and ST4.
- Load ST1 and ST2 such that:

Equation 15. Setpoint Resistance

$$\text{Setpoint} = \frac{2.5 * ST2}{ST1 + ST2}$$

where:

ST1 + ST2 must be greater than 5 kΩ.

Setpoint is in Volts.

ST1 and ST2 are in Ohms (1206 size).

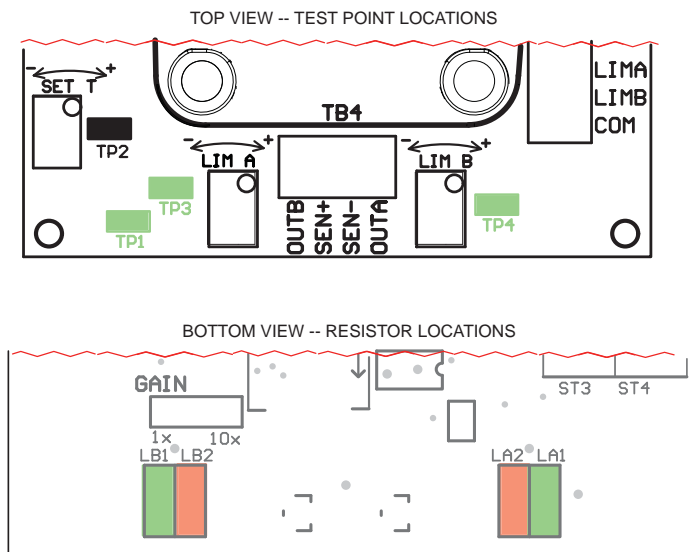

Figure 32. LIMA & LIMB Settings

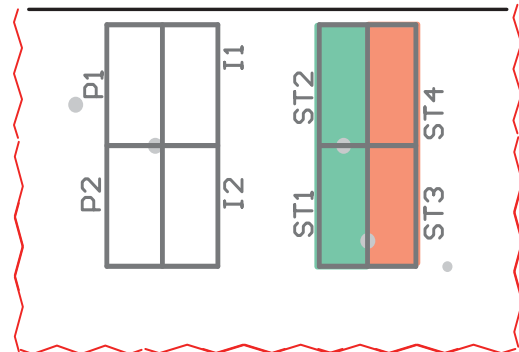

Figure 33. Test Point Locations

SAFE OPERATING AREA CALCULATION

The Safe Operating Area of the WTC controller is determined by the amount of power that can be dissipated within the output stage of the controller. If that power limit is exceeded permanent damage can result.



DO NOT EXCEED THE SAFE OPERATING AREA (SOA). EXCEEDING THE SOA VOIDS THE WARRANTY.

Refer to the Wavelength Electronics website for the most up-to-date SOA calculator for our products. The online tool is fast and easy to use, and also takes into consideration operating temperature.

<http://www.teamwavelength.com/support/calculator/soa/soatc.php>

SOA charts are included in this datasheet for quick reference, however we recommend you use the online tools instead.

Follow these steps to determine if the driver will be operating within the SOA.

- Refer to the thermoelectric datasheet to find the maximum voltage (V_{MAX}) and current (I_{MAX}) specifications
- Calculate the voltage drop across the controller:
 $V_{DROP} = V_S - V_{MAX}$ (V_S is the power supply voltage)
- Mark V_{DROP} on the X-axis, and extend a line upward
- Mark I_{MAX} on the Y-axis, and extend a line to the right until it intersects the V_{DROP} line
- On the X-axis, mark the value of V_S
- Extend a diagonal line from V_S to the intersection of the V_{DROP} and I_{MAX} lines; this is the Load Line
- If the Load Line crosses the Safe Operating Area line at any point, the configuration is not safe

If the SOA Calculator indicates the WTC will be outside of the Safe Operating Area, the system must be changed so that less power is dissipated within the driver. See Wavelength Electronics Application Note [AN-LDTC01: The Principle of the Safe Operating Area](#) for information on shifting the Load Line.

Figure 34 illustrates the SOA curve for the WTC.

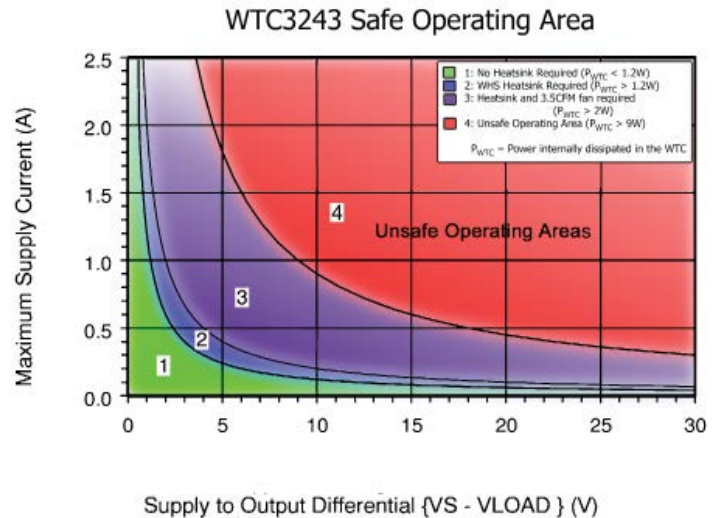

Figure 34. SOA for WTC3243

An example SOA calculation is shown in Figure 35 where:

$V_S = 12$ Volts (Point C)

$V_{MAX} = 5$ Volts

$I_{MAX} = 1$ Amp (Point B)

$V_{DROP} = 12 - 5 = 7$ Volts (Point A)

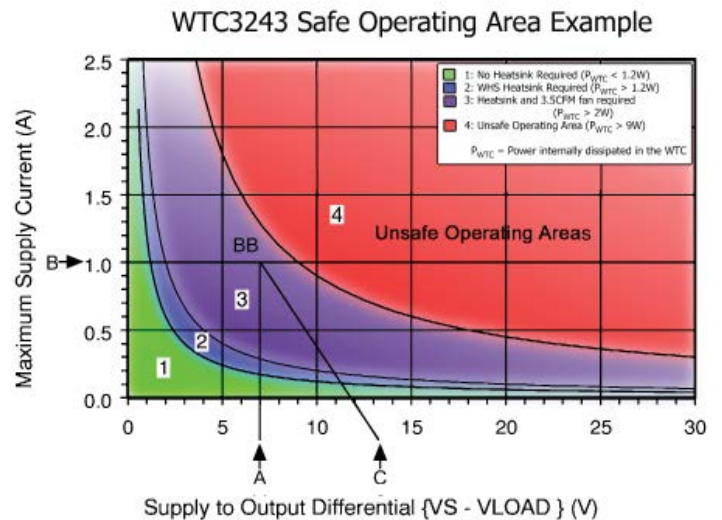

Figure 35. Example SOA Calculation

Refer to Figure 35 above and note that the Load Line is in the Unsafe Operating Areas for use with no heatsink (1) or the heatsink alone (2), but is outside of the Unsafe Operating Area for use with heatsink and fan (3).

TROUBLESHOOTING

PROBLEM	POTENTIAL CAUSES	SOLUTIONS
Temperature is decreasing when it should be increasing -OR- Temperature is increasing when it should be decreasing	The TEC may be connected backwards to the WTC	The convention is that the red wire on the TEC module connects to TEC+ (Pin 12) and the black wire to TEC- (Pin 11). If your TEC is connected in this manner and the problem persists, the TEC module itself may be wired in reverse. Switch off power to the system, reverse the connections to the WTC, and then try again to operate the system. TEC wiring polarity is dependent on temperature sensor type (NTC vs. PTC). Verify that the polarity is correct for the sensor type you are using (see Table 7. OUTA & OUTB Wiring Configuration on page 18).
Temperature increases beyond setpoint and will not come down.	The heatsink may be inadequately sized to dissipate the heat from the load and the TEC module, and now the system is in a condition called thermal runaway	- Increase the size of the heatsink, add a fan to blow air over the heatsink, and/or reduce the ambient air temperature around the heatsink. - Apply a thick layer of thermal paste or use thermal washers between the load, the TEC surfaces, and the heatsink.
	The TEC and heatsink are not adequately sized for the thermal load	The heat being generated by the load may be too great for the TEC to pump to the heatsink; a larger TEC may be needed. Consult our Technical Note TN-TC01: Optimizing Thermoelectric Temperature Control Systems and Application Note AN-TC09: Specifying Thermoelectric Coolers .
Temperature does not stabilize very well at the setpoint	There may be poor thermal contact between components of the thermal load	Use thermal paste or washers between the load / TEC and the TEC / heatsink interfaces. Ensure the temperature sensor is in good thermal contact with the load.
	Unit may be operating outside of the ideal region of the temperature sensor	The sensor type and bias current should be selected to maximize sensitivity at the target temperature. Thermistors provide the best performance, particularly for applications where a single setpoint temperature must be accurately maintained. For example, at 25°C a 10 kΩ thermistor has a sensitivity of 43 mV / °C, whereas an RTD sensor has a sensitivity of 4 mV / °C.
	Proportional control term may be set too high	Reduce the value of the proportional term. For more information, reference our technical note TN-TC01: Optimizing Thermoelectric Temperature Control Systems .
	Heatsink may not be sized correctly or may not have adequate airflow	Ambient temperature disturbances can pass through the heatsink and thermoelectric and affect the device temperature stability. Choosing a heatsink with a larger mass and lower thermal resistance will improve temperature stability. Adding a fan across the thermoelectric's heatsink may be required.
Temperature does not reach the setpoint	Current driven to the TEC or heater may be insufficient	Increase the current limit – but DO NOT exceed the specifications of the TEC or heater.
	The controller may not have sufficient compliance voltage to drive the TEC or heater	Increase the power supply voltage; be certain to verify that the controller is within the Safe Operating Area with Wavelength's Temperature Controller SOA calculator: http://www.teamwavelength.com/support/calculator/soa/soatc.php
	The sensor may not have good contact with the heatsink and load.	Use thermal paste or washers between the load / TEC and the TEC / heatsink interfaces. Contact the thermoelectric manufacturer for their recommended mounting methods.

TROUBLESHOOTING, continued

PROBLEM	POTENTIAL CAUSES	SOLUTIONS
Temperature takes too long to reach setpoint	Temperature sensor may be too far from the thermoelectric	Avoid placing the temperature sensor physically far from the thermoelectric. This is typically the cause for long thermal lag and creates a sluggish thermal response that produces considerable temperature overshoot near the desired operating temperature.
	Current limit may be set too low	Increase the current limit but DO NOT exceed the specifications of the TEC or heater.
The WTC3293 is not producing current	The P GAIN or I TERM may be turned all the way counter clockwise (CCW)	Turn the P GAIN and I TERM trimpot screws clockwise to the setting suggested in Table 5 .
The setpoint is 1 V higher than it should be when using the HSET input	The VSET SOURCE jumper may be still in place	Remove the VSET jumper to use HSET input.
Overshoot with Small Loads	The I TERM may be overcompensating	With small, fast loads, the WTC has a tendency to overshoot by up to 10°C. This problem is caused by overcompensation by the integrator. Take the I TERM out of the system by placing a shorting jumper between Pin 6 (+1V) and Pin 7 (I)

MECHANICAL SPECIFICATIONS

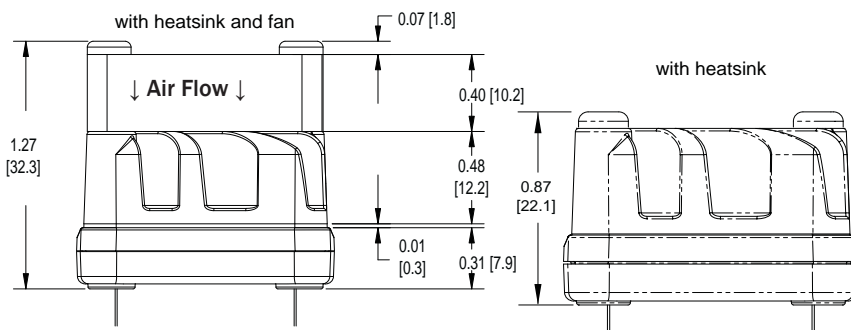

Weights

WTC3243	0.6 oz
WHS302 Heatsink	0.5 oz
WXC303/4 Fan	0.3 oz

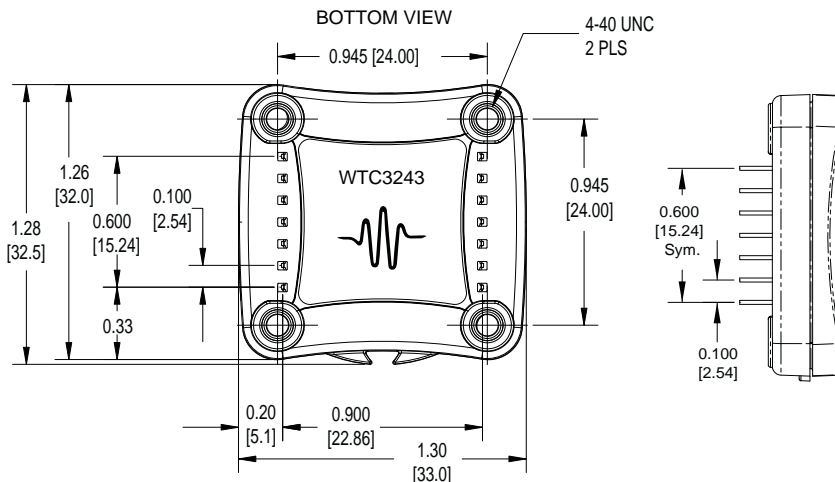

PCB FOOTPRINT

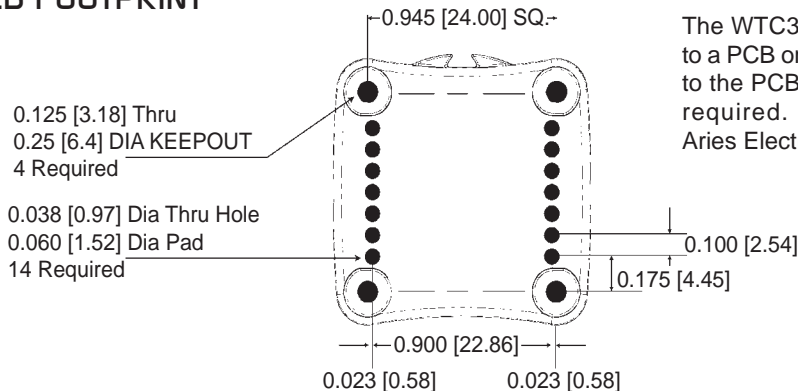

The WTC3243 can be directly soldered to a PCB or installed in a socket soldered to the PCB. Two 7-pin SIP sockets are required. Wavelength recommends Aries Electronics, PN 25-0513-10.

WTC3243 ASSEMBLED WITH HEATSINK & FAN

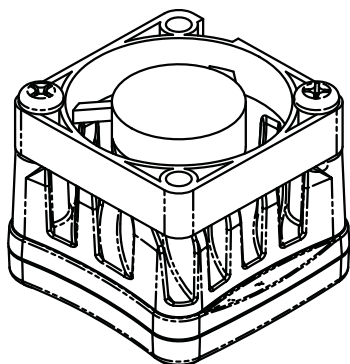

* Actual fan wire configuration may be different than shown.

Fan can be rotated on the WTC so the location of the wires matches your PCB layout.

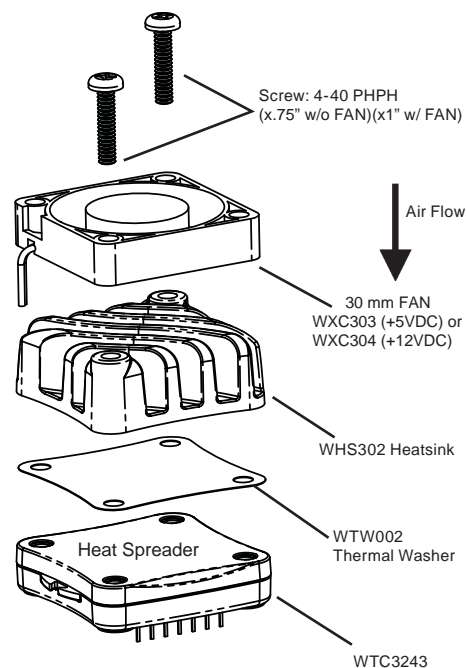

All dimensions are inches [mm]. All tolerances are ±5%.

MECHANICAL SPECIFICATIONS, continued

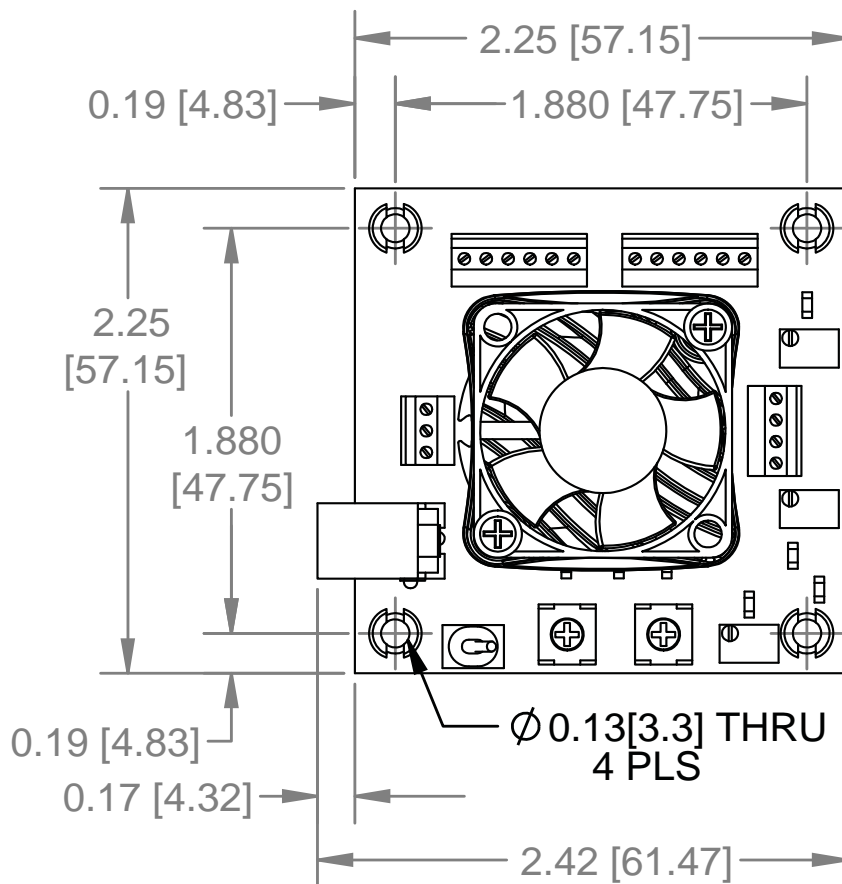

Weights

WTC3293 + WTC3243	1.6 oz
WHS302 Heatsink	0.5 oz
WXC303/4 Fan	0.3 oz

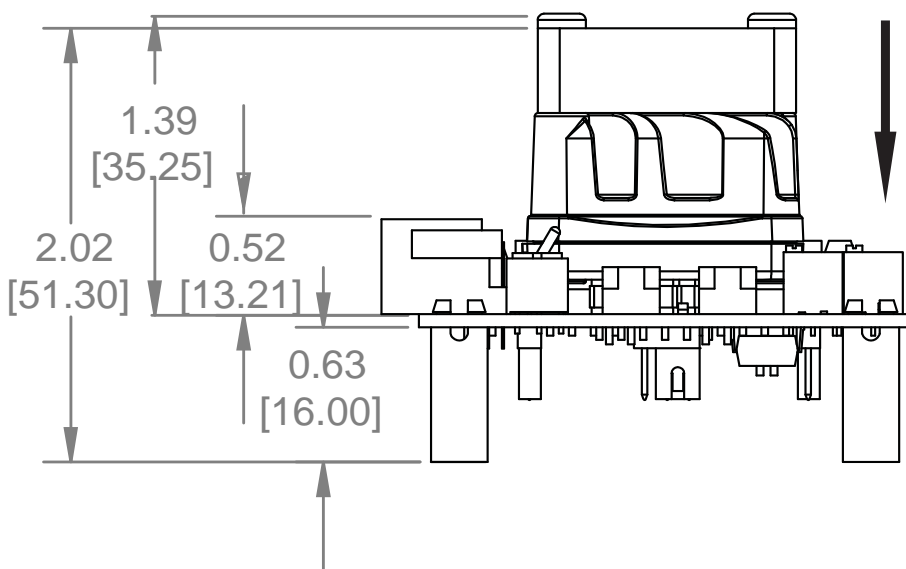

Direction for Recommended Airflow

The WTC3243 connects to the evaluation board by two 7-pin SIP sockets. The socket manufacturer is Aries Electronics, PN 25-0513-10.

All dimensions are inches [mm]. All tolerances are ±5%.

CERTIFICATION AND WARRANTY

CERTIFICATION

Wavelength Electronics, Inc. (Wavelength) certifies that this product met its published specifications at the time of shipment. Wavelength further certifies that its calibration measurements are traceable to the United States National Institute of Standards and Technology, to the extent allowed by that organization's calibration facilities, and to the calibration facilities of other International Standards Organization members.

WARRANTY

This Wavelength product is warranted against defects in materials and workmanship for a period of one (1) year from date of shipment. During the warranty period, Wavelength will, at its option, either repair or replace products which prove to be defective.

WARRANTY SERVICE

For warranty service or repair, this product must be returned to the factory. An RMA is required for products returned to Wavelength for warranty service. The Buyer shall prepay shipping charges to Wavelength and Wavelength shall pay shipping charges to return the product to the Buyer upon determination of defective materials or workmanship. However, the Buyer shall pay all shipping charges, duties, and taxes for products returned to Wavelength from another country.

LIMITATIONS OF WARRANTY

The warranty shall not apply to defects resulting from improper use or misuse of the product or operation outside published specifications. No other warranty is expressed or implied. Wavelength specifically disclaims the implied warranties of merchantability and fitness for a particular purpose.

EXCLUSIVE REMEDIES

The remedies provided herein are the Buyer's sole and exclusive remedies. Wavelength shall not be liable for any direct, indirect, special, incidental, or consequential damages, whether based on contract, tort, or any other legal theory.

REVERSE ENGINEERING PROHIBITED

Buyer, End-User, or Third-Party Reseller are expressly prohibited from reverse engineering, decompiling, or disassembling this product.

NOTICE

The information contained in this document is subject to change without notice. Wavelength will not be liable for errors contained herein or for incidental or consequential damages in connection with the furnishing, performance, or use of this material. No part of this document may be translated to another language without the prior written consent of Wavelength.

SAFETY

There are no user-serviceable parts inside this product. Return the product to Wavelength Electronics for service and repair to ensure that safety features are maintained.

LIFE SUPPORT POLICY

This important safety information applies to all Wavelength electrical and electronic products and accessories:

As a general policy, Wavelength Electronics, Inc. does not recommend the use of any of its products in life support applications where the failure or malfunction of the Wavelength product can be reasonably expected to cause failure of the life support device or to significantly affect its safety or effectiveness. Wavelength will not knowingly sell its products for use in such applications unless it receives written assurances satisfactory to Wavelength that the risks of injury or damage have been minimized, the customer assumes all such risks, and there is no product liability for Wavelength. Examples of devices considered to be life support devices are neonatal oxygen analyzers, nerve stimulators (for any use), auto-transfusion devices, blood pumps, defibrillators, arrhythmia detectors and alarms, pacemakers, hemodialysis systems, peritoneal dialysis systems, ventilators of all types, and infusion pumps as well as other devices designated as "critical" by the FDA. The above are representative examples only and are not intended to be conclusive or exclusive of any other life support device.

REVISION HISTORY

DOCUMENT NUMBER: WTC3243-00400

REV.	DATE	CHANGE
M	April 2014	Updated Quick Connect Instructions
N	August 2014	Added Accuracy specification
O	August 2015	Updated Compliance Voltage specification



**WAVELENGTH
ELECTRONICS**

51 Evergreen Drive
Bozeman, Montana 59771

406-587-4910 (tel)
406-587-4911 (fax)



Sales & Tech Support
sales@teamwavelength.com
techsupport@teamwavelength.com